

W. CHARLES & M. MCKAIN.

MACHINE FOR MAKING TAIL-NUTS.

No. 185,495.

Patented Dec. 19, 1876.

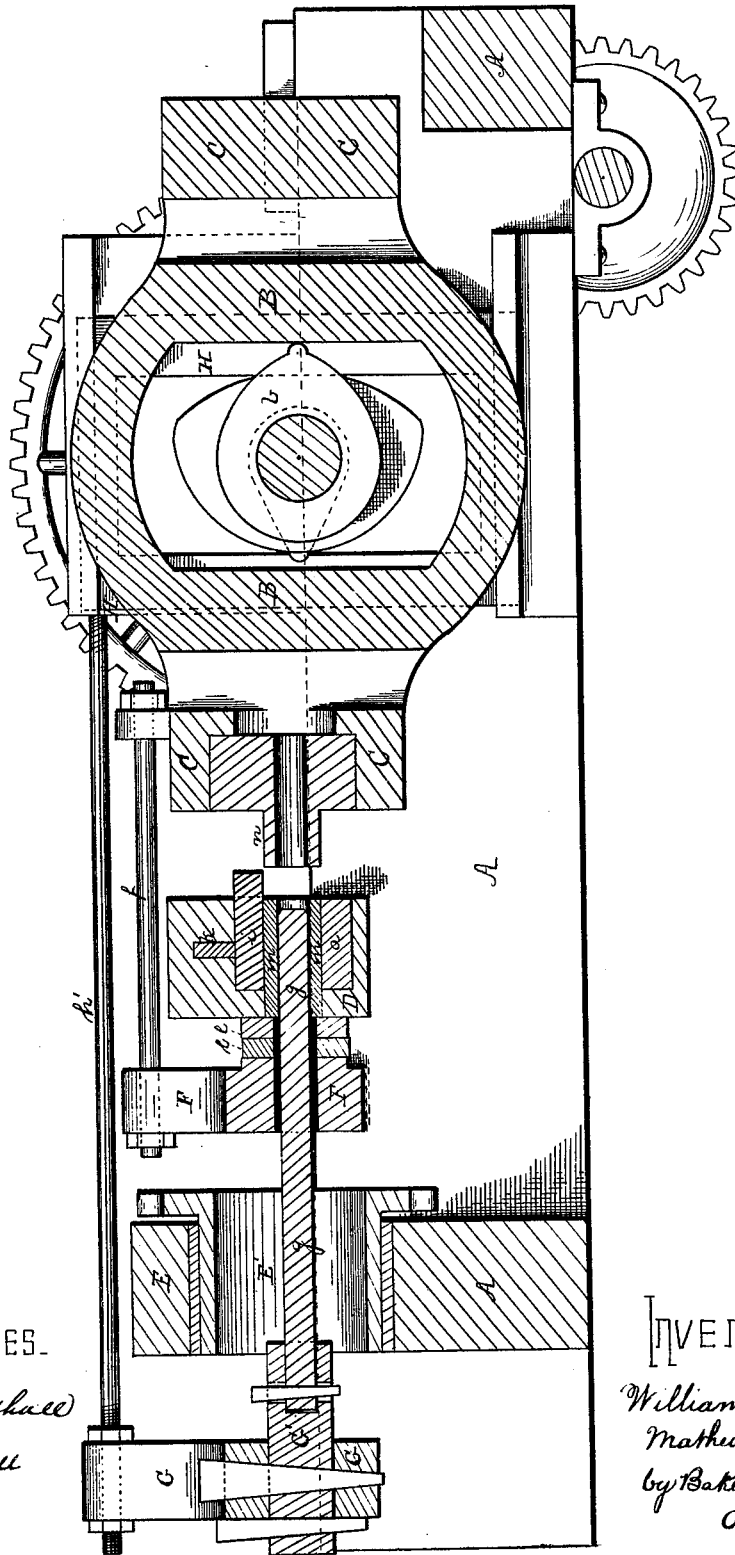

WITNESSES.
R. W. Fenshau
J. K. Bakewell

INVENTORS.
William Charles
Mathew McKain
 by *Bakewell & Carr*
 Attorneys.

W. CHARLES & M. McKAIN.

MACHINE FOR MAKING TAIL-NUTS.

No. 185,495.

Patented Dec. 19, 1876.

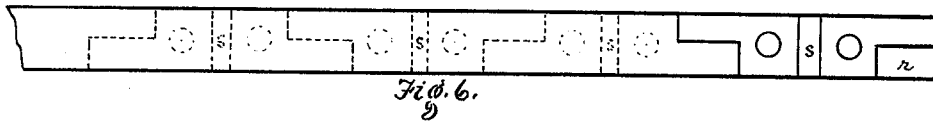
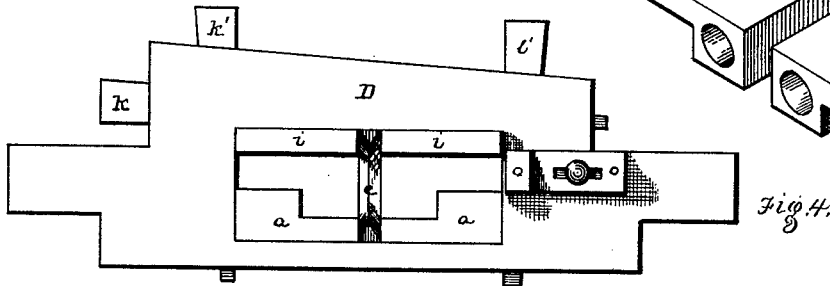
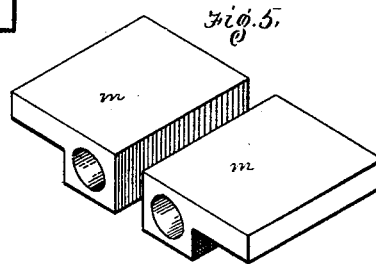
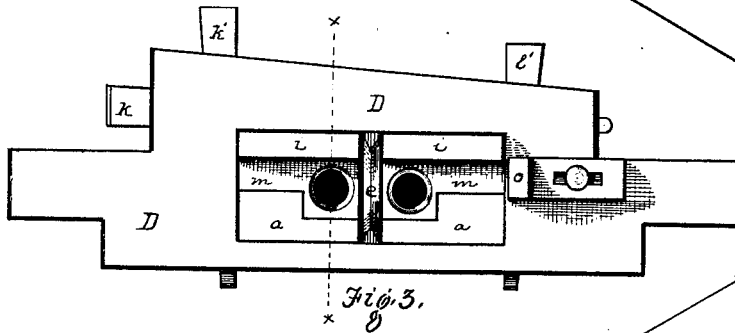
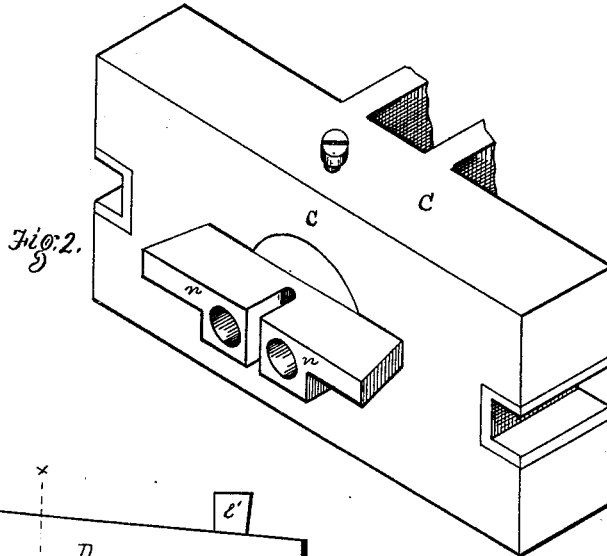

Witnesses.

R. Wrenshall

J. K. Bakewell

INVENTORS.

William Charles.

Mathew McKain

by Bakewell & Kerr
Attorneys.

UNITED STATES PATENT OFFICE.

WILLIAM CHARLES, OF CHARTIERS TOWNSHIP, ALLEGHENY COUNTY, AND
MATTHEW MCKAIN, OF PITTSBURG, PENNSYLVANIA.

IMPROVEMENT IN MACHINES FOR MAKING TAIL-NUTS.

Specification forming part of Letters Patent No. **185,495**, dated December 19, 1876; application filed
October 30, 1876.

To all whom it may concern:

Be it known that we, WILLIAM CHARLES, of Chartiers township, and MATTHEW MCKAIN, of Pittsburg, both in the county of Allegheny and State of Pennsylvania, have invented a new and useful Improvement in Machines for the Manufacture of Tail-Nuts; and we do hereby declare the following to be a full, clear, and exact description thereof, reference being had to the accompanying drawing, forming a part of this specification, in which—

Figure 1 is a longitudinal vertical section on one side of the center of a machine embodying our improvements. Fig. 2 is a perspective view of the male dies. Fig. 3 is a front elevation of the following dies and matrices. Fig. 4 is a similar view to Fig. 3, the following dies being removed to clearly indicate the form of the box or matrix. Fig. 5 is a detached view of the following dies; and Fig. 6 is a diagram, showing the small amount of scrap formed in manufacture.

Like letters refer to like parts wherever they occur.

Our invention relates to the construction of the dies and matrices of nut-machines, and has for its object the production of tail-nut blanks from the bar with a reduced waste in the amount of scrap formed, and with less labor than is at present required to produce such blanks.

We will now proceed to describe our invention, so that others skilled in the art to which it appertains may apply the same.

In the drawing, A represents a suitable bed or frame for supporting the operative mechanism. B is a cam-yoke, provided with T-heads C, in which are secured the male dies. The cam-yoke B is usually provided with two T-heads, so that, if from wear or other causes it becomes desirable, the yoke may be reversed. Said heads move in guides on the main frame A, and the yoke is operated by a cam or eccentric, *b*, on the main shaft. D is the cross-bar which supports the die-box, and is rigidly secured to the main frame, as is also the cross-head E, which supports the press-screw E'. F is the press-plate, movable in guides on frame A, and operated from and with the cross-head C by means of stretchers

f. G indicates the punch-head, in which is secured the punch-mandrel G', that carries the punches *gg'*. This head is operated from yokes H through the stretchers *h'*. *ll* are a series of liners, which may be interposed between the press plate F and dies when needed. The punches are shown as blunt, but may be tapered, if desired.

The above-specified parts constitute no part of the present invention, but are simply shown that the invention may be clearly understood, and may be constructed as represented, modified at pleasure, or replaced by other well-known mechanism.

Our die-boxes or matrices and dies may be formed in single sets, where it is only desired to form a single blank at a time; but we prefer to make them in pairs, and shall so describe them in the present instance.

In the cavity of the cross-bar D we arrange a series of pieces, *a*, of L or other suitable form, and a series of straight pieces, *i*, the latter of which are preferably permitted to project slightly beyond the face of the bar D, and are held in position by keys *k k' v*, or like means. These pieces *i i* act as guides for adjusting the bar. The cavity thus formed is divided into two chambers by a vertical plate, *e*, having beveled edge. This will form two matrices for tail-nut blanks having square bodies. If it is desired to make the body of different polygonal form, or even round, the same can be readily done by changing the shape of the pieces *a* and *i* by means well known to the skilled nut-manufacturer.

o is a stop or lug formed on or secured to the cross-bar D at the edge of the far matrix, to serve as a guide and stop when feeding in the iron. *m m* are the loose or traverse dies, of a shape corresponding to the matrices employed, having a large or body piece perforated for the passage of the punch, and a small projecting or wing piece. These dies are operated from the press-plate F, in the usual manner.

Secured in the T-head C are the upper or male dies *n n*, with central openings, and having the wing-pieces, and, in other respects, of the same general form as the traverse-dies *m*. Where two blanks are to be formed at once,

as in the machine chosen for illustration, the dies are cast or forged together in order that they can be more easily set in the T-head.

The above constitute our improved devices, which we employ as follows: The bar or other iron, being properly heated, is fed into the machine across the die-boxes, until the end is arrested by the stop *o*. The dies *n n* of the T-head are then caused to advance and cut from the bar two nut-blanks having tails or projections, forcing the same into the matrices and against the lower dies *m m*, where they are held during the action of suitable punches *g g*, and whence they are finally discharged on the retreat of dies *n n* by the advance of dies *m m*, caused by the press-plate, in the usual manner of making the ordinary nut.

During the cutting of the first pair of blanks from the bar a rectangular piece, as shown at *r* of the diagram, and also a small piece, *s*, corresponding to the beveled plate which separates the matrices or die-boxes, is all the scrap that will be formed, and as the bar is turned at each succeeding operation of the dies, the scrap thereafter is reduced to a small piece, *s*, for every two tail-nut blanks punched. If, however, a blunt punch is used, the usual

amount of scrap arising from the punchings will of course be made.

The common method of forming tail-blanks is by means of drop-punches, and, as in all cases where blanks are thus produced a web is formed, involving the loss of much good material in the shape of scrap.

By our present method the tail-nut blank is much more rapidly and accurately formed, with less labor or manipulation, and very little scrap or waste.

Having thus described our invention, what we claim, and desire to secure by Letters Patent, is—

In a nut-machine, one or more sets of winged dies and matrices, substantially of the shape and construction, and for the purpose, specified.

In testimony whereof we, the said WILLIAM CHARLES and MATTHEW MCKAIN, have hereunto set our hands.

WILLIAM CHARLES.
MATTHEW MCKAIN.

Witnesses:

JAMES I. KAY,
F. W. RITTER, Jr.