

A. FOX.
CORN-PLANTER.

No. 185,515.

Patented Dec. 19, 1876.

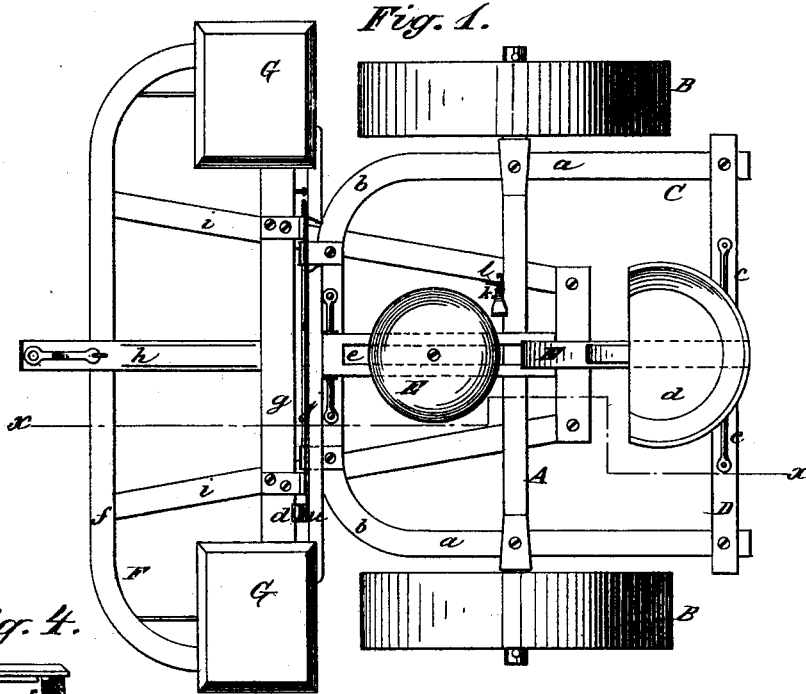

Fig. 4.

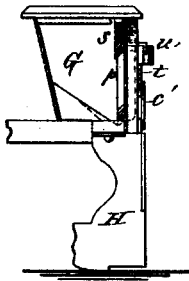

Fig. 2.

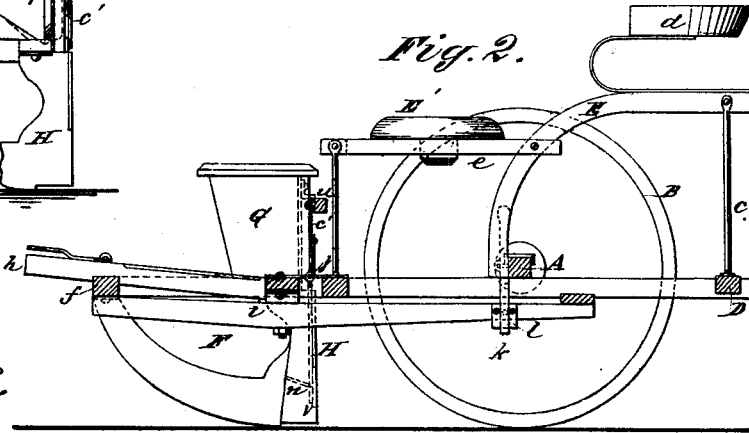
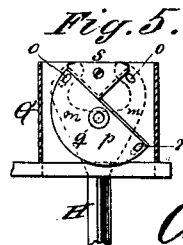
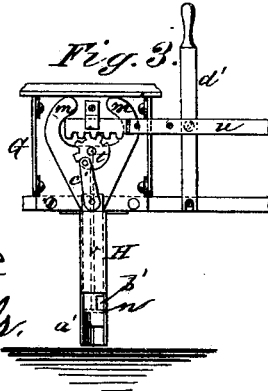
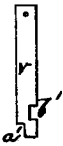

Fig. 6.



WITNESSES:

H. Rydquist.
John Goethals.

INVENTOR:

A. Fox.

BY

Munn & Co.
ATTORNEYS.

UNITED STATES PATENT OFFICE.

ALPHEUS FOX, OF ROCK FALLS, ILLINOIS.

IMPROVEMENT IN CORN-PLANTERS.

Specification forming part of Letters Patent No. **185,515**, dated December 19, 1876; application filed September 30, 1876.

To all whom it may concern:

Be it known that I, ALPHEUS FOX, of Rock Falls, in the county of Whitesides and State of Illinois, have invented a new and Improved Corn-Planter, of which the following is a specification:

Figure 1 is a top view. Fig. 2 is a section on line *x x* in Fig. 1. Fig. 3 is a rear view of the dropping device. Fig. 4 is a transverse section of one of the seed-boxes. Fig. 5 is a detail view of the device for delivering corn to the droppers. Fig. 6 is a detail view of the dropping-valve.

Similar letters of reference indicate corresponding parts.

The invention will first be described in connection with the drawing, and then pointed out in the claims.

The passages formed in the forked conductors are continued separately nearly to the bottom of the boot or leg of the planter, where they are stopped by an inclined bottom piece, and provided with a slide-valve, which, moved up and down, will drop corn alternately from one and the other of the passages in the boot. This valve is connected to a crank-pin projecting from a segmental pinion placed on a short shaft, which also supports the disk inside of the seed-box. A bar is provided that gives motion simultaneously to the segmental pinions.

The invention further consists in the peculiar manner of constructing the frame supporting the seed-boxes and the main frame from bent wood or iron.

Referring to the drawing, A is the axle of the machine, supported by the covering-wheels B. C is a frame, supported by the axle, which consists of a bent piece of wood, *a*, which forms the front and two sides of the frame, having the rounded corners *b*. D is a cross-bar connecting the ends of the bent portion C. A curved piece of wood, E, is clamped to the center of the axle, and supported by braces *c*, that are attached to the cross-bar D. To this curved piece the driver's seat *d* is attached. Midway between the seat *d* and the axle a slotted piece, *e*, is secured, having its outer end supported by braces that rest on the part C. A seat, E, is arranged to slide on the slotted piece *e*. A frame, F, for supporting

the seed-boxes and boots or legs of the machine consists of the bent piece *f*, forming the front and sides, and the bar *g*, connecting the rear ends of the piece *f*. The tongue *h* is attached to the center of this frame, and the arms *i i* are also attached to its under side and run back under the frame C, where they are connected by a cross-bar. The frame F is hinged to the frame C at *j*, and is held in position by the catch *k*, pivoted to the axle A, and engaging with a catch-plate, *l*, attached to one of the arms *i*.

G G are seed-boxes, attached to the rear of the frame F, directly in front of the wheels B, and *m m* are passages made in the back of the casting forming the back of the seed-box. These passages converge, and are continued downward in the boot H of the planter to the inclined bottom *n*. *o o* are apertures in the back of the seed-box, communicating with the passages *m m*, and *p* is a portion of a disk whose semi-diameter reaches from its shaft *q* to the bottom of the seed-box.

Inclined holes *r r* are made in the disk, which are capable of taking the required quantity of seed from the box, and delivering it to the apertures *o* as the disk is oscillated. S is a buffer of rubber, which limits the motion of the disk. A segmental pinion, *t*, is secured to the shaft *q* outside of the seed-box. The seed-boxes on opposite sides of the machine are similarly arranged, and a bar, *u*, having racks at each end, connects the pinions *t* of the two seed-boxes.

A slide, *v*, (shown in detail in Fig. 6,) is placed at the back side of the passages in the boot, and is cut away at *a'* and *b'*, forming a valve, which, when moved up or down, opens the passages *m* alternately. A short connecting rod or link, *c'*, connects the slide *v* to a pin projecting from the face of the pinion *t*. A lever, *d'*, is pivoted to the bar *u*, and also to the rear bar *g* of the frame F. A curved cutter runs from the lower extremity of the boot to the front of the frame F, where it is bolted.

The operation of the machine is as follows: The seed-boxes are filled with corn, and as the machine advances the operator, who sits upon the lower seat, operates the oscillating disks by means of the hand-lever. As the

holes in the disks rise out of the corn they contain a sufficient number of kernels of corn for a single hill, and when opposite the hole in the back of the seed-box that leads to the converging passages the corn falls into the passage and drops to the bottom of the boot, when it is allowed to drop out into the furrow made by the machine by the movement of the slide in the back of the boot. The supporting-wheels of the machine, which have a wide tread, cover the corn as they advance.

Having thus described my invention, I claim as new and desire to secure by Letters Patent—

1. The arrangement of the passages *m m*, disk *p*, apertures *r r* and *o o*, slide *v*, pinion *t*, bar *u*, and lever *d'*, to shorten the stroke of cross-bar and allow the rope check-row to be used, as herein shown and described.

2. The double notched slide for the second drop, a notch being left open from one hill to another, and the corn allowed time to pass out.

ALPHEUS FOX.

Witnesses:

GEO. W. NANCE,
A. A. NANCE.