

G. HOWLAND.
MACHINE FOR WINDING PAPER INTO ROLLS.

No. 185,538.

Patented Dec. 19, 1876.

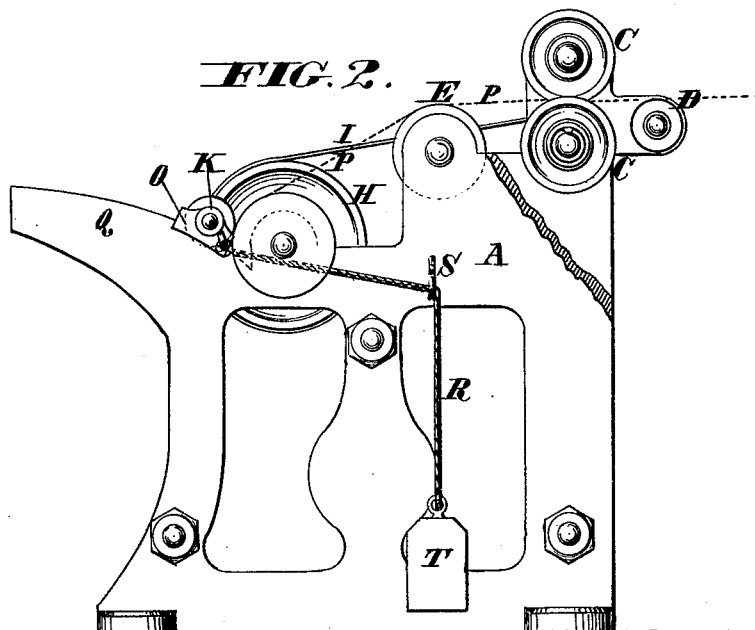
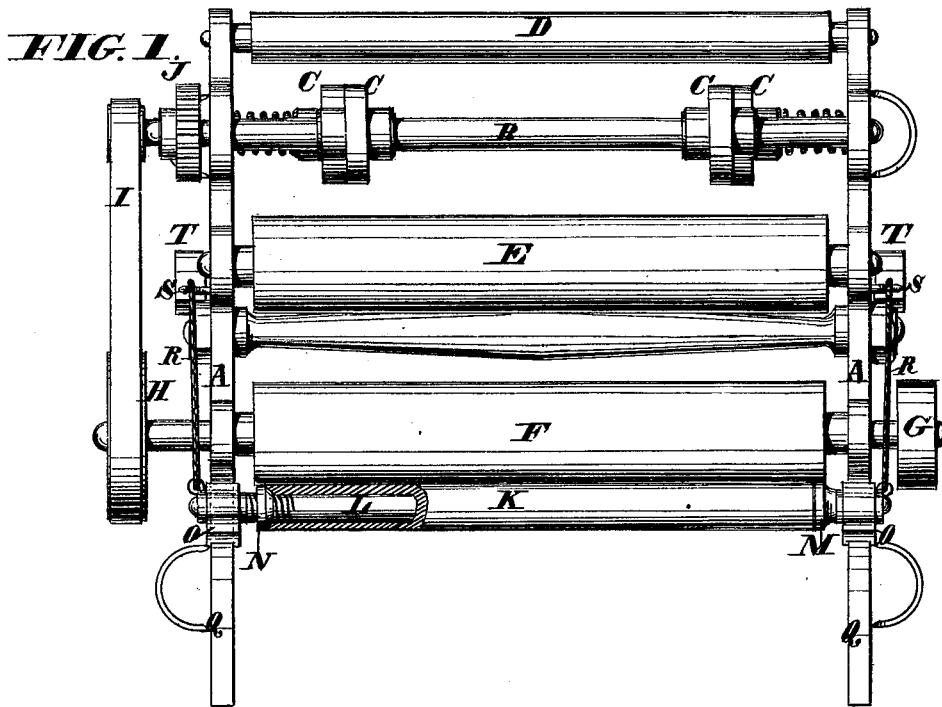

WITNESSES
Chas. J. Gooch
W. H. Pearce

INVENTOR
Gardner Howland
By *Knights* Attorneys.

UNITED STATES PATENT OFFICE.

GARDNER HOWLAND, OF LOS ANGELES, CALIFORNIA, ASSIGNOR TO EDGAR O. HOWLAND, OF MECHANICSVILLE, NEW YORK; AND SAID E. O. HOWLAND ASSIGNOR TO LEMIRA J. HOWLAND, OF FRANKFORD, PA.

IMPROVEMENT IN MACHINES FOR WINDING PAPER INTO ROLLS.

Specification forming part of Letters Patent No. **185,538**, dated December 19, 1876; application filed August 17, 1875.

To all whom it may concern:

Be it known that I, GARDNER HOWLAND, of the city and county of Los Angeles, in the State of California, have invented a new and useful Improvement in Machines for Winding Paper or other Material into a Roll, of which the following is a specification:

The object of my invention is to effect the reeling of a web of paper with gradually-decreasing tension from the center to the outside, or without the possibility of an increase of tension toward the outside, which might impair the solidity of the roll or render one part liable to slide on the other. To this end I mount the roller carrying the reel-core in boxes which slide on curved ways, so as to cause the roll of paper, as it increases in size, to bear with reduced pressure on the surface of the friction-roller by which it is rotated. These curved ways are formed so as to crowd the core hard against the drum, compelling the shaft and its boxes to climb up the ways in its first commencement on a very steep incline. Then, as the roll increases in size, the incline becomes less steep, and as the roll becomes heavier, and the winding farther away from the fulcrum of the shaft, so that it offers increasing resistance, it is climbing up portions of the curved ways that are less and less steep, causing the pinch against the drum to be the same; or, if it is desired, it may be adjusted to be a little less as the roll increases in size, so as to insure against tightening on the periphery, as I have found by experience that it is no special detriment to be a trifle looser at the periphery than at the shaft; but I have also found by experience that it must in no case be tighter.

In the accompanying drawings, Figure 1 is a plan of a machine embodying my invention. Fig. 2 is a side elevation of the same with a part of the frame broken away.

A A represent parts of the main frame of a paper winding or reeling machine, which may take the web of paper as it comes from the reel or the calendar-rolls of the paper-mill, or may be used for rewinding paper which has been already reeled. B B may represent a

pair of cutter-shafts, carrying cutters C C, to trim the web to desired and uniform width. D E are carrier-rolls. F is a friction-roller driven by a belt on the pulley G, or by other means. The shaft of the roller F may also carry a pulley, H, which, through the medium of a belt, I, drives one of the cutter-shafts, said shafts being geared together by pinions J. K represents the tubular core on which the roll of paper is wound. This core is slipped over a shaft, L, in customary manner, and secured thereto by a fixed collar, M, and a nut-collar, N, the latter being screwed on a thread formed to receive it on the shaft L. The journals of the shaft L run in boxes O, fitted to slide on segmental ways Q, so formed and arranged that as the roll of paper increases in size it will bear in a more nearly horizontal direction, and, consequently, with reduced pressure, against the surface of the driving-roller F.

The web of paper in course of winding is represented at P in dotted lines. R R are cords passing over loops or pulleys S, and receiving weights T, to draw the roll of paper against the driving-roller F as it is wound.

The curved ways require to be made on a different-sized circle, according to the different material to be wound, difference in tenderness of the material, and in the size of roll wished for. I find that for winding ordinary printing-paper, and winding in rolls of from three to four feet diameter, a section about three feet long, of a circle of about six feet diameter, is about the required proportion. One end of this section wants to stand about three inches inside toward the shaft from the outer surface of this drum, and by an arm extending to the shaft, and fastened to the frame of the winder, or, better, be a part of the frame and hold the box in which runs the shaft of the drum, causing the connection to be firm and rigid, sufficient to support a movable half ton in weight suspended without tremble or swaying. I place the inner end of this curved way about on a level with the shaft, and then elevate the other end of it, so that when the de-

sired size of roll is obtained the boxes that slide on the curved ways have but a slight tendency to crowd against the drum, depending upon the half-ton weight in the roll working away from the center to create the desired pressure by the friction of its boxes on the circle.

The following is claimed as new:

The curved ways Q, in combination with

the driving-roller and the winding-roller, the latter supported in boxes O, resting on the ways Q, up which they climb as the roll of paper increases in size, causing it to bear with decreasing pressure against the driving-roller.

GARDNER HOWLAND.

Witnesses:

D. S. LOVEJOY,

C. C. LAMB.