

O. P. KENNEDY.

CAR-STOVES.

No. 185,545.

Patented Dec. 19, 1876.

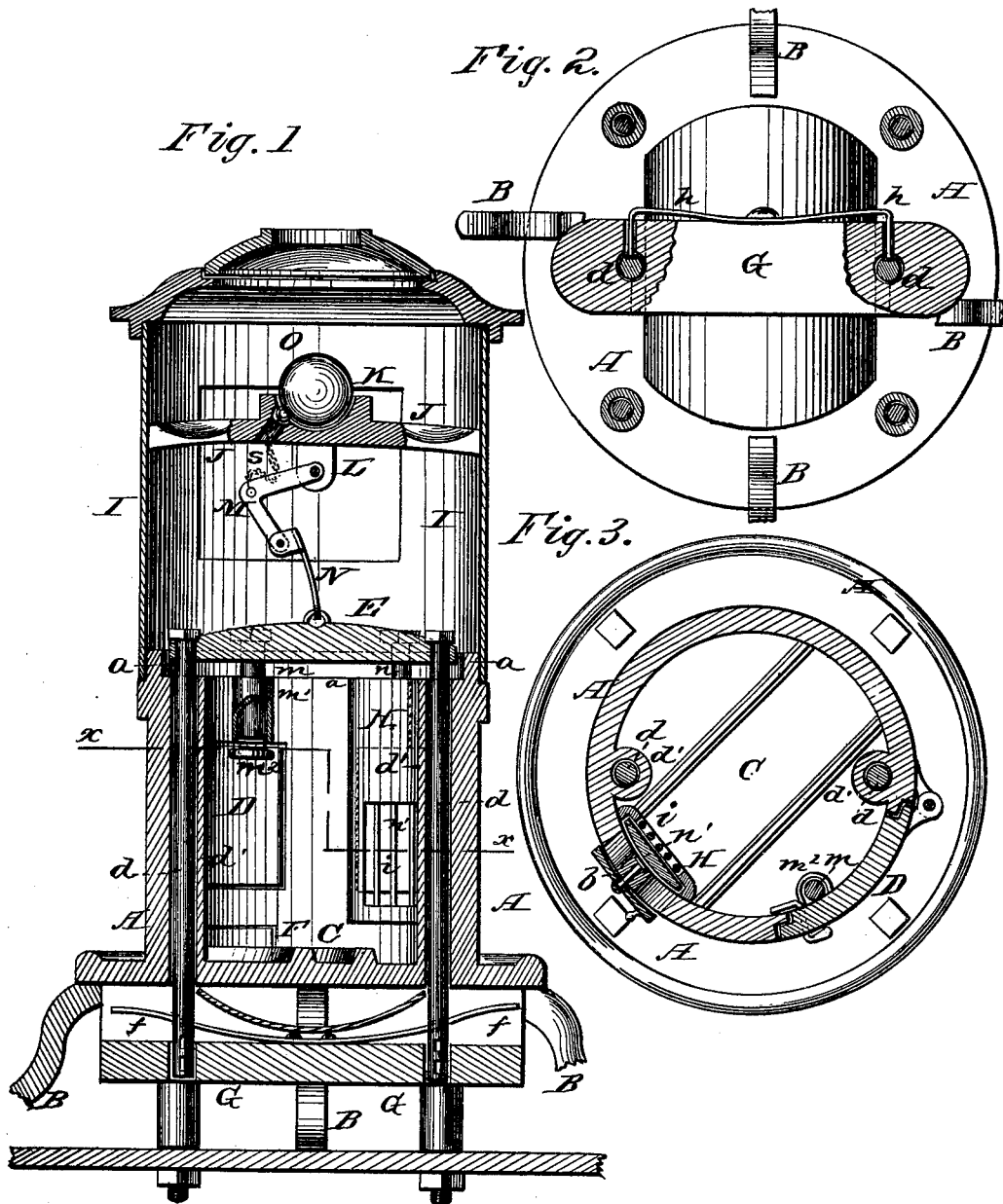

Witnesses:

F. C. Deterick
F. H. Duffy

Inventor:

Oliver P. Kennedy

Per: *C. H. Watson & Co. Attorneys.*

UNITED STATES PATENT OFFICE.

OLIVER P. KENNEDY, OF LUNDY'S LANE, PENNSYLVANIA.

IMPROVEMENT IN CAR-STOVES.

Specification forming part of Letters Patent No. **185,545**, dated December 19, 1876; application filed June 14, 1876.

To all whom it may concern:

Be it known that I, OLIVER P. KENNEDY, of Lundy's Lane, in the county of Erie and State of Pennsylvania, have invented certain new and useful Improvements in Stoves for Railroad-Cars; and I do hereby declare that the following is a full, clear, and exact description thereof, which will enable others skilled in the art to which it appertains to make and use the same, reference being had to the accompanying drawings, and to the letters of reference marked thereon, which form a part of this specification.

The nature of my invention consists in the construction and arrangement of a stove for railroad-cars, as will be hereinafter more fully set forth.

In the annexed drawing, Figure 1 is a central vertical section. Fig. 2 is a bottom view, partly in section; and Fig. 3 is a transverse section on line *x x*, Fig. 1.

A represents the base of my stove, supported upon legs B B, and bolted to the floor of the car. On this base is the fire pot or chamber C, either cast therewith or permanently secured thereto. In the upper edge of the fire-pot, around the inside, is a shoulder or offset, *a*; in the front, near the bottom, is a draft-register, *b*; and in one side is the door D.

E represents a plate, of such dimensions that when pressed down it will fit closely on the offset or shoulder *a*. This plate has, on opposite sides, near its edge, two downwardly-projecting rods, *d d*, which enter vertical tubes *d' d'*, formed on the inside of the fire-chamber, and act as guides for the proper movement of the plate. The rods *d* extend down through the bottom of the stove into an elongated box, G, formed underneath the fire-chamber. Through this box, from end to end, is passed a spring, *f*, the ends of which pass through holes in the lower ends of the rods *d*, as shown. The action of this spring is to press the rods *d* upward, and hold the plate E a certain distance above the shoulder *a*. When the plate is pressed down on this shoulder two spring-catches, *h h*, on the box G spring into other holes in the ends of the rods *d*, and lock the plate E down on the shoulder *a*. From the

plate E also depend two other rods, *m* and *n*. The rod *m* enters a tube, *m*¹, on the inside of the fire-chamber, above the door D, and on the inside of said door is formed a prolongation, *m*², of said tube. The rod *n* has, on its lower end, a flat plate, *n'*, and passes down through the vertical draft-tube H. This tube extends from top to bottom of the fire-chamber, and is open at both ends. Directly opposite the register it has an opening, *i*, with grating inserted therein. The rods *m* and *n* are of such length that when the plate E is in its normal position above the shoulder *a* the plate *n'* will be above the register-opening, and the rod *m* will not have entered the tube *m*² on the door; but as soon as the plate is pressed down on the shoulder the rod *m* locks the door, and the plate *p* closes the draft-opening.

Above the fire-chamber C is a drum, I, in which is a cross-bar, J, with a bowl, K, in the center, and a down-projecting arm, L, in the center, on the under side. This arm is slotted, and in the same is pivoted an elbow-lever, M, the lower end of which is, by a bar, N, connected with the center of the plate E. The upper end of the lever is, by a chain, *s*, connected with a heavy ball, O, which lies in the bowl K, the chain passing from the ball through a hole in the bowl to the lever.

When the stove is in use the plate E is held above the shoulder *a* a suitable distance, and the ball O rests in the bowl K, when the door of the fire chamber can be opened and closed at will, and the air enter through the draft-opening. The smoke passes out through a pipe in the top of the drum. Should, from any cause, the stove tip over to either side, the ball O will at once fall out of the bowl K, and, by its chain, draw up one end of the lever M, thereby forcing down the other end, which is connected to the plate E, and said plate is pressed down upon the shoulder *a* and instantly locked thereon by the spring-catches *h h*. This, as already stated, locks the door D and closes the draft-opening, so that the fire is completely confined in the fire-chamber, and cannot, under any circumstances, get out, thus preventing any accident by fire.

Immediately below the door D is situated

an ash-door, F, for the purpose of cleaning out the stove.

Having thus fully described my invention, what I claim as new, and desire to secure by Letters Patent, is—

1. In combination with the fire-box C and automatic closing-plate E, the rod *m*, tube *m*¹ on the inside of the fire-box, and the prolongation *m*² on the inside of the door, for the purposes set forth.

2. In combination with the fire-box C, draft-register *b*, and automatic closing-plate E, the rod *n*, with plate *n*¹, and draft-flue H, with opening *i*, for the purposes set forth.

3. The guide-rods *d* and tubes *d*¹, in combination with the plate E and fire-box C, for the purposes set forth.

4. The combination, with the fire-box C and automatic closing-plate E, of the rods *d* *d*, box G, spring *f*, and spring-catches *h* *h*, as and for the purposes set forth.

In testimony that I claim the foregoing as my own I affix my signature in presence of two witnesses.

OLIVER P. KENNEDY.

Witnesses:

C. W. PURCELL,
E. G. STEVENS.