

J. W. LATCHER.

WASH-BOARD.

No. 185,553.

Patented Dec. 19, 1876.

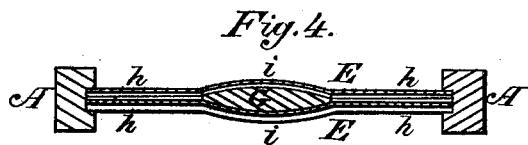
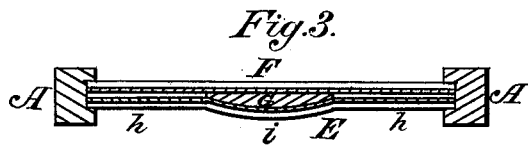
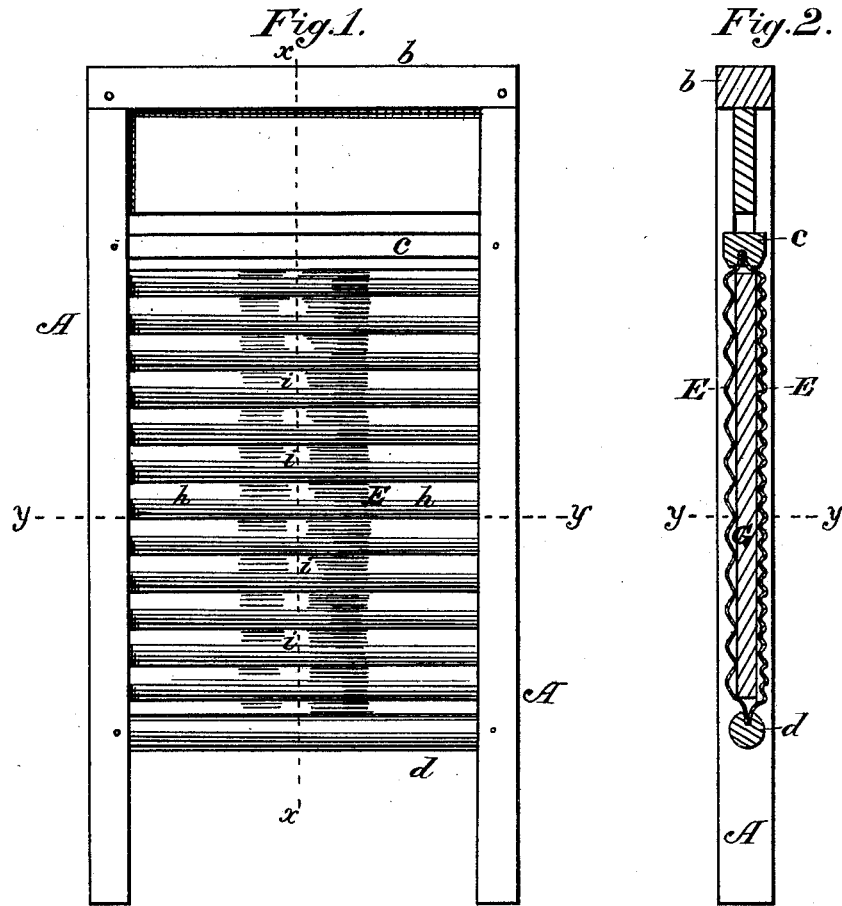

Attest:  
H. Schott  
Joseph C. Wildman

Inventor:  
John W. Latcher

# UNITED STATES PATENT OFFICE.

JOHN W. LATCHER, OF JOHNSTOWN, ASSIGNOR TO CLOTILDA N. JENKINS,  
OF CONKLVILLE, NEW YORK.

## IMPROVEMENT IN WASH-BOARDS.

Specification forming part of Letters Patent No. **185,553**, dated December 19, 1876; application filed  
November 17, 1876.

*To all whom it may concern:*

Be it known that I, JOHN W. LATCHER, of Johnstown, in the county of Fulton and State of New York, have invented a Wash-Board, of which the following is a specification:

This invention relates to that class of wash-boards which have two opposite washing-surfaces, and the same composed wholly of two separate sheets of metal forming said opposite sides or washing-surfaces, and differs from other wash-boards in having the right and left portions of each washing-surface perfectly flat, while the central portion is convex, or springs from the right and left flat or plane portions abruptly to a considerably raised or convex corrugated surface from the top to the lower edge of each of the two sheets of metal composing the two opposite washing-surfaces. The abrupt elevation in the central portion is formed so that a bar of wood may be inserted between the two sheets of corrugated zinc, and at the same time permit the two flat portions or the right and left portions of the two plates to touch each other over their flat inner surfaces, which gives greater stiffness than would be were the two plates composing the two washing-surfaces held apart by a central bridge, and having no support between the said plates from their centers to their lateral edges.

Figure 1 is a vertical elevation of my invention. Fig. 2 is a vertical central sectional view of the same, taken in the line *xx*, Fig. 1. Figs. 3 and 4 are horizontal sectional views of my invention, taken in the line *yy*, Fig. 1, showing the central convex surfaces.

A A represent the uprights or standards; *b*, the cap or top piece; *c*, top grooved bar for retaining the zinc plates; *d*, the lower bar for like purpose, as will be seen by reference to Fig. 2.

The standards are grooved in the usual way for the reception and retention of the two zinc plates E F, as they both enter one groove in each standard.

I stamp the two zinc plates E E or E F in such a manner as to receive a double-convex or plano-convex wooden bar, G, between them, and at the same time admitting of a close con-

tact of the two flat or plane portions *h* of the metal plates E F or E E, which will be more fully understood by reference to Figs. 2, 3, and 4.

By this form or plan of construction it will be seen and understood that the two plates E E or E F afford a mutual support to each other through the medium of the wooden bar G.

The two opposite sheets of zinc may be corrugated, as shown in Fig. 2, in conjunction with the described central wooden bar G, though, independently of said bar G, it would not be near the diversity of the corrugations on the opposite sides.

One of the sheets may be flat through its entire length and breadth, as shown in Fig. 3 at F, in combination with the zinc plate E, which is provided with a convex washing-surface through its central portion, as seen at *i*.

Both plates could not be formed like plate F, as they would not admit the central bar G, and consequently would not have sufficient stiffness, nor would a wash-board so constructed have the advantage of a raised washing-surface above the lateral plates *h h*, as is well established.

I have merely shown that a flat sheet of zinc may be used in conjunction with a sheet having a convex central corrugated washing-surface, and would therefore prefer a wash-board having both of its faces or washing sides provided with raised centers.

I am aware that wash-boards are in use having raised centers or curved plates, with supports on their reverse side, though having only one washing-surface, such as is shown in the patent of C. C. Gridley and C. W. Pratt, patented May 2, 1876, No. 176,783.

I am also aware that wash-boards having two faces or washing-surfaces formed on one piece, and the same waved or curved transversely with respect to the horizontal corrugations or flutings, are also in use, such as shown in L. B. Hartt's patent, July 18, 1865, No. 48,811, and I would therefore disclaim all such forms of construction.

What I claim as new, and desire to secure by Letters Patent, is—

A wash-board having two separate plates of corrugated metal, when one or both of said plates are stamped with a raised central portion, *i*, for the reception of the double-convex or plano-convex vertical bar G, sub-

stantially as shown and described, and for the purposes specified.

JOHN W. LATCHER.

Witnesses:

WARREN I. COLLAMER,

B. H. WEST.