

J. RICHTER.  
STUMP-PULLER.

No. 185,580.

Patented Dec. 19, 1876.

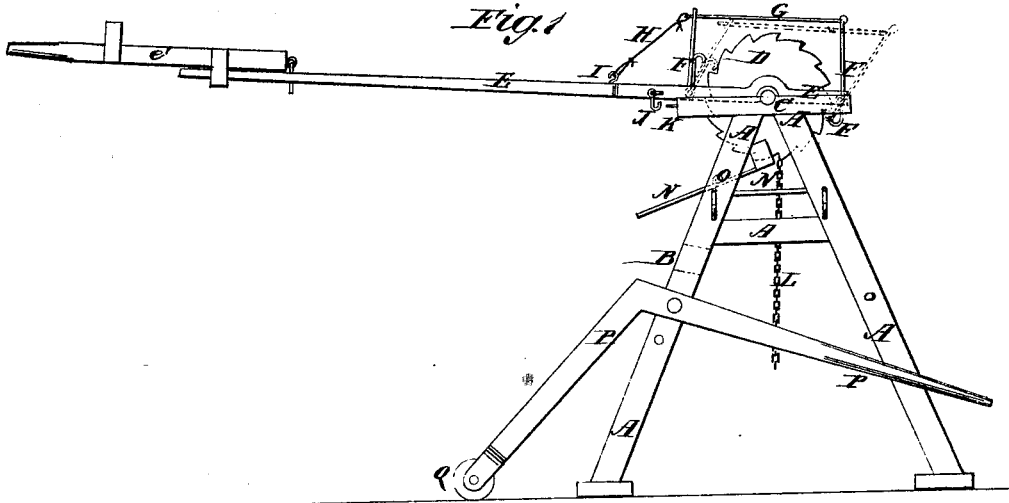

Fig. 2.

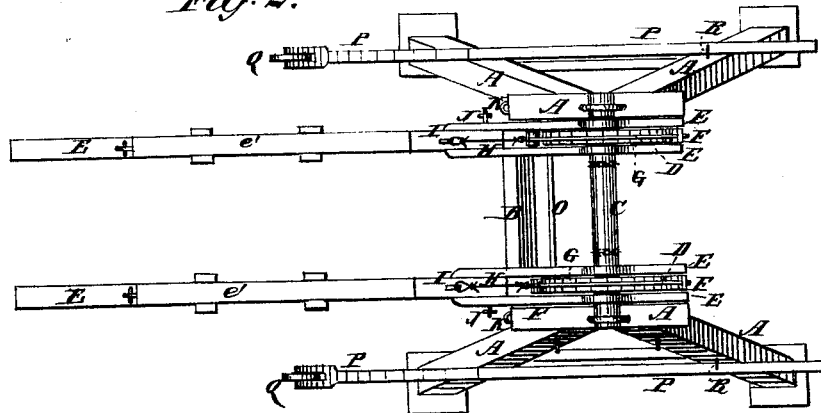
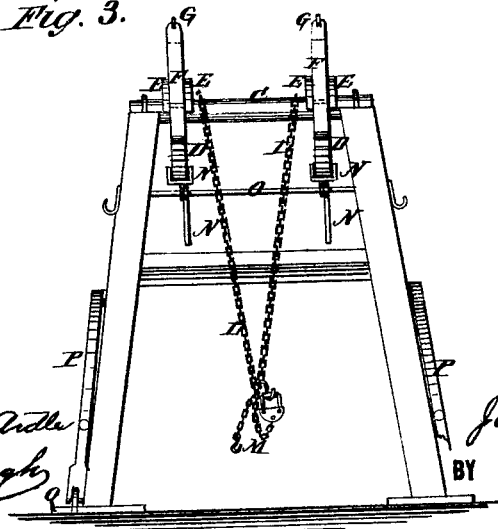

Fig. 3.



WITNESSES:

*Francis McArdle*  
*J. Scarborough*

INVENTOR:

*J. Richter*

BY

*Munn & Co.*

ATTORNEYS.

# UNITED STATES PATENT OFFICE.

JOSEPH RICHTER, OF JORDAN, MINNESOTA.

## IMPROVEMENT IN STUMP-PULLERS.

Specification forming part of Letters Patent No. 185,580, dated December 19, 1876; application filed October 7, 1876.

### *To all whom it may concern:*

Be it known that I, JOSEPH RICHTER, of Jordan, county of Scott, and State of Minnesota, have invented a new and Improved Stump-Puller, of which the following is a specification:

Figure 1 is a side view of my improved machine. Fig. 2 is a top view of the same. Fig. 3 is a front view of the same.

The object of this invention is to furnish an improved machine for pulling stumps, roots, &c., which shall be simple in construction, convenient in use, and effective in operation.

The invention consists in the combination of the shaft, the ratchet-wheels, the two pairs of pawls, the connecting-rods, the chains, and the holding-pawls with each other and with the frame; in the combination of the cords or chains and the hooks with the pawls, the connecting-rods, and the levers.

Similar letters of reference indicate corresponding parts.

A are the side frames, which are made narrow at their upper ends, and the front posts of which are connected by a cross-bar, B. In bearings in the top bars of the side frames A revolve the journals of a shaft, C, to which, near the inner sides of the side frames A, are attached two ratchet-wheels, D. E are two levers, the forward parts of which are slotted to receive the ratchet-wheels D, and which ride upon and are pivoted to the shaft C. To the levers E, in front and rear of the ratchet-wheels D, are pivoted two pawls, F, the upper ends of which are connected above the said wheels D by rods G. The claws or hooks of the forward pawls F are below the pivoting-points, and the hooks or claws of the rear pawls F are above the pivoting-points.

By this construction, when the rear ends or handles of the levers E are raised, the weight of the rear pawls F will hold both pawls in gear with the ratchet-wheel, and when the rear ends or handles of the said levers E are lowered the weight of the rear pawls will hold both pawls in gear with the ratchet-wheels.

The pawls F are held away from the ratchet-wheels D by the cords or chains H, one

end of which is attached to the upper end of the rear pawls F, and the other ends of which are hooked upon hooks I, attached to the levers E. The levers E are supported in place, when not in use, by hooks J, pivoted to them, and hooking into eyes K, attached to the rear ends of the top bars of the frames A. To the shaft C, at the inner sides of the ratchet-wheels D, are attached the ends of the chain L, to the middle of which is attached a hook to be hooked into the chain M, which is passed around or hooked upon the stump or root to be drawn.

By this construction, by operating the levers E, the shaft C will be turned, winding up the chain M, and drawing the stump. The shaft C is held from being turned back by the resistance of the stump when the levers E are being raised to make another stroke by the pawls N, which engage with the teeth of the ratchet-wheels, and are pivoted to and slide upon a rod, O, attached to the rear posts of the side frames A.

The outer ends of the pawls N project to serve as weights to hold their engaging ends against the teeth of the ratchet-wheels D, and as handles for sliding them away from the said wheels.

The levers E may have extensions *e'* hinged to them near their ends, which may be turned down, as shown in Fig. 1, to lengthen the levers when heavy work is to be done, and which may be turned up out of the way, as shown in Fig. 2, when not required for use.

To the middle parts of the rear posts of the frames A are pivoted the levers P, the handles of which project at the front of the machine. The other ends of the levers P are bent downward at or near their pivots, at an obtuse angle, and to their ends are pivoted small wheels Q, so that by raising the handles of said levers the machine may be transported upon the wheels Q. To the front posts of the frames A are attached stop-pins R, for the levers P to strike against when their handles are raised to throw the weight more directly upon the wheels Q.

Having thus described my invention, I claim as new and desire to secure by Letters Patent—

1. The combination of the shaft C, the ratchet-wheels D, the levers E, the two pairs of pawls F, the connecting-rods G, the chains L M, and the holding-pawls N with each other, and with the frame A B, substantially as herein shown and described.

2. The combination of the cords or chains

H and hooks I with the pawls F, the connecting-rods G, and the levers E, substantially as herein shown and described.

JOSEPH RICHTER.

Witnesses:

JOHNSON BRAGG,  
JOSEPH KEENE.