

R. WILSON.
COMBINED RAKES AND TEDDERS.
No. 185,612. Patented Dec. 19, 1876.

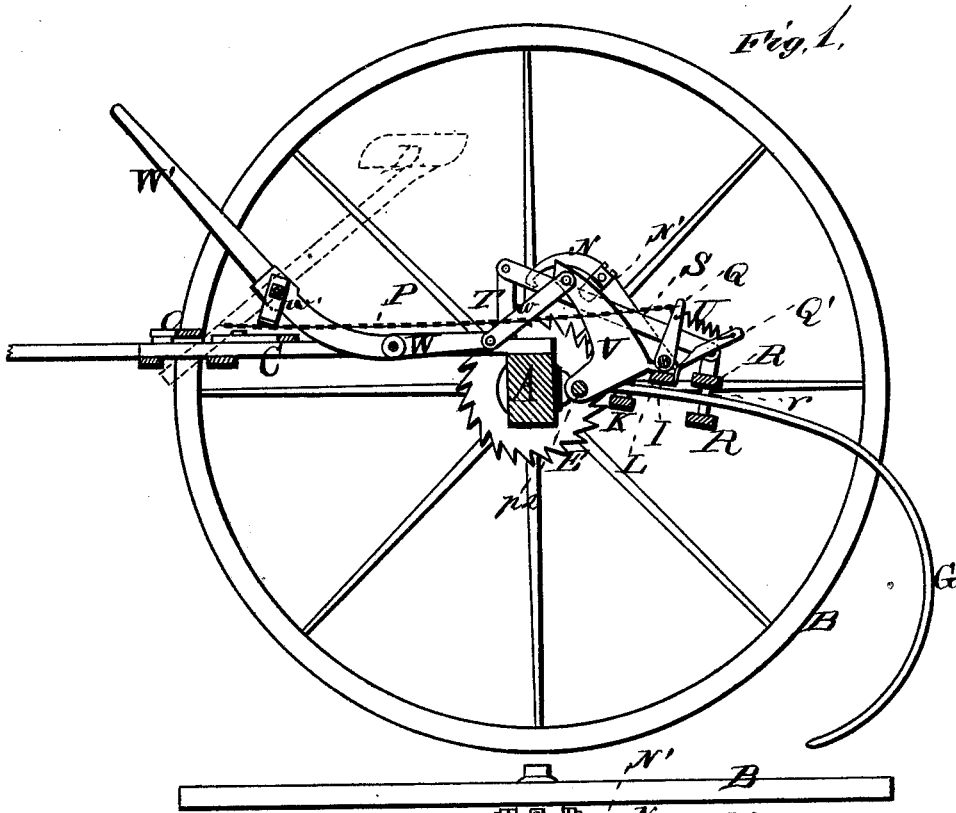

Fig. 1.

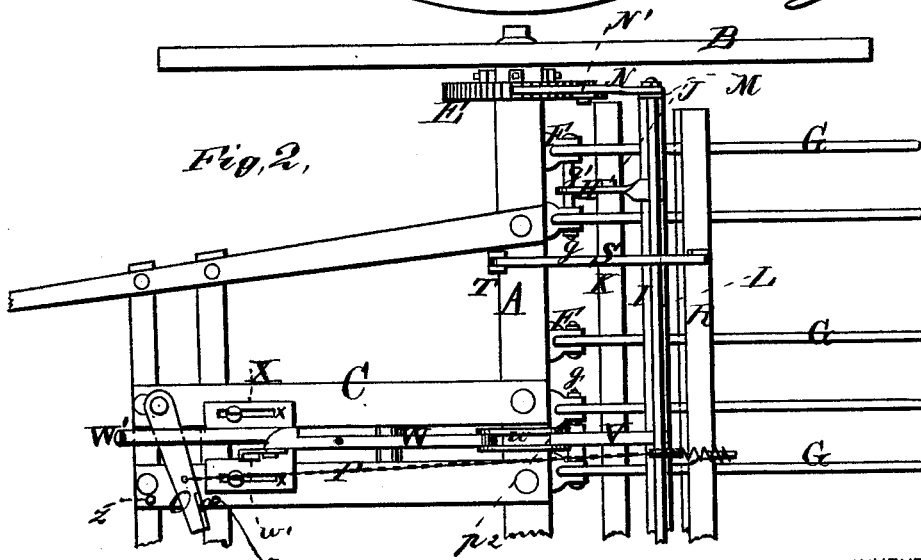

Fig. 2.

WITNESSES
E. H. Bates
Robert G. Smith

INVENTOR.
Robert Wilson.
Gilmore Smith.
 ATTORNEYS

R. WILSON.
COMBINED RAKES AND TEDDERS.

Patented Dec. 19, 1876.

No. 185,612.

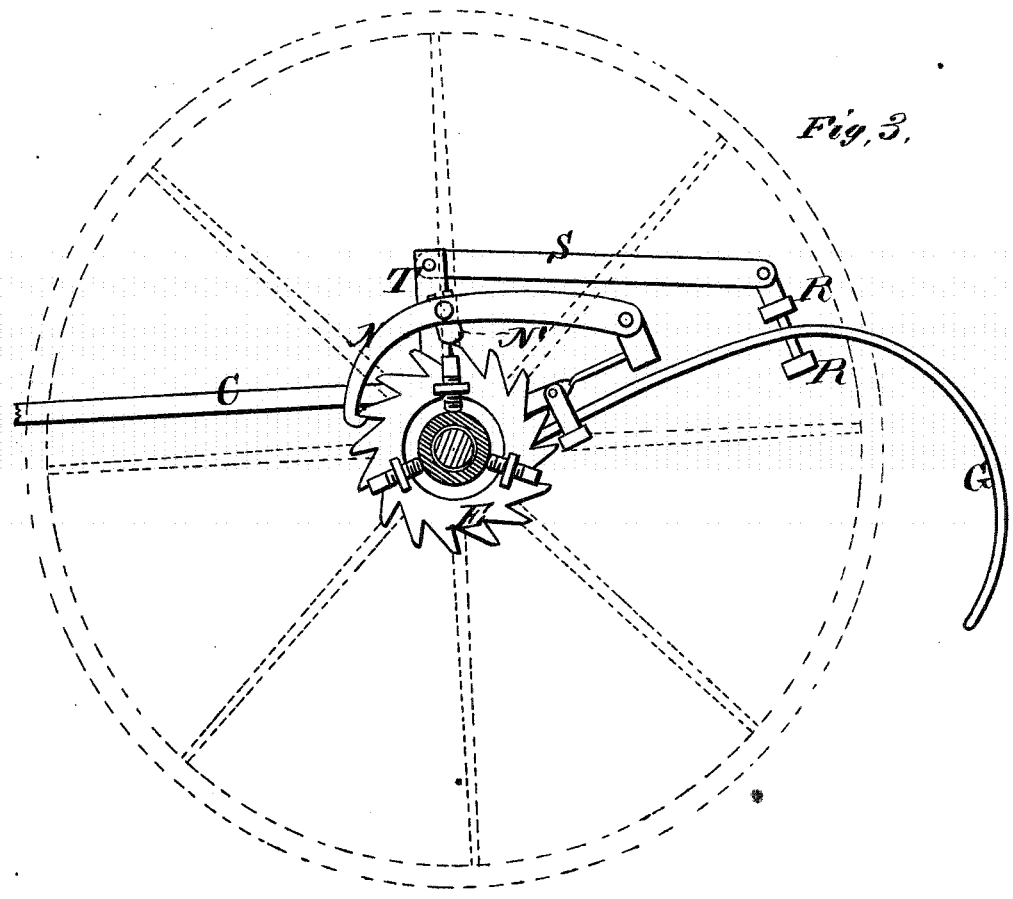

Fig. 4.



WITNESSES
 E. H. Bates.
 Robert Everett

INVENTOR
 Robert Wilson,
 Gilman & Smith & Co.,
 ATTORNEYS.

UNITED STATES PATENT OFFICE.

ROBERT WILSON, OF ITHACA, NEW YORK.

IMPROVEMENT IN COMBINED RAKE AND TEDDER.

Specification forming part of Letters Patent No. 185,612, dated December 19, 1876; application filed October 28, 1876.

To all whom it may concern:

Be it known that I, ROBERT WILSON, of Ithaca, in the county of Tompkins and State of New York, have invented a new and valuable Improvement in Self-Dumping Hay Rake and Tedder; and I do hereby declare that the following is a full, clear, and exact description of the construction and operation of the same, reference being had to the annexed drawings, making a part of this specification, and to the letters and figures of reference marked thereon.

Figure 1 of the drawings is a representation of a central vertical section of my self-dumping hay rake and tedder. Fig. 2 is a plan view of the same. Fig. 3 is a longitudinal vertical sectional view, and Fig. 4 is a detail view thereof.

This invention relates to horse hay-rakes, and is an improvement upon the devices secured to me by reissued Letters Patent No. 6,214, dated January 5, 1875, and Letters Patent No. 164,356, dated June 8, 1875; and it consists in certain improvements therein, as will be hereinafter set forth.

In the annexed drawings, A designates the axle of my apparatus, connecting transporting-wheels B B, and C designates a frame secured thereto, and constructed as described in my patents hereinbefore mentioned. Said frame is attached by its rear end to axle A, and supports an ordinary driver's seat, D. The hub of each one of said wheels B is provided on its inner end with a ratchet-wheel, E, which may be either permanently attached or removable, (though I prefer the latter,) but in any case turns with said transporting-wheel.

To the rear of axle A are secured a series of brackets, F, which are bifurcated to receive eyes on the upper and front ends of rake-teeth G. Each one of said teeth is pivoted in one of said brackets by means of a pivot-pin or pivot-bolt, *g*, which passes through the eye on the upper end of said tooth, and also through the perforated forks or lips of said bracket. The number of said teeth and attachments may be varied considerably. Near each end of said axle A two of said brackets are arranged close together, and instead of short pivot-bolts *g*, they are provided with

a long pivot-rod, *g'*, which passes through both brackets. The construction of said rods *g'* is the same in both cases, and each of them is provided with a metal arm or plate, H, which supports a presser-bar, I, that operates to hold down the rake-teeth. Said arm or plate is provided with a rigidly-attached shorter arm, J, at right angles thereto, which upholds a suspended lifting-bar, K, that operates to raise said rake-teeth. When said teeth are raised for dumping, said presser-bar is immediately over said lifting-bar. At other times it is above and behind the same. The said teeth pass between these bars, which are parallel to said axle, and have about equal length therewith.

On the top of presser-bar I, at the ends thereof, a rock-shaft, L, is journaled in bearing-plates M M. Said rock-shaft carries at each end a curved pawl, N, which is adapted to engage with one of said ratchet-wheels E when said shaft is rocked forward. This forward rocking of said shaft is effected by means of a horizontal foot-bar, O, which is pivoted by its rear end to the top of frame C, at the front thereof, and which is connected by a chain, P, or its equivalent, to an arm, Q, on said rock-shaft. Said foot-bar is provided at its free end with a raised foot-rest, *o*, within convenient reach of the driver's seat. By pressing his foot against the rear of said foot-rest, the driver causes the said rock shaft to rock forward, as described, bringing the said pawls into engagement with the said ratchet-wheels. The revolution of transporting-wheels B then causes the said pawls to be drawn forward and downward, and thereby throws upward rock-shaft L, pressure-bar I, and lifting-bar K, which latter lifts teeth G, so as to dump the loads of hay from the same. This action continues until a tripping-lug, N', on the under side of each one of said pawls N comes into contact with one of the teeth on one of said ratchet-wheels, when said pawl will be raised out of engagement, and said rake-teeth will fall. My device is thus an automatic dumper and rake-tooth replacer.

Said tripping-lugs N' N' are slotted at their upper ends at *n*, as shown in Fig. 4, so as to be capable of vertical adjustment on said pawls N. In this way I regulate the height

to which the said rake-teeth are raised, and also the frequency of their replacement. The farther said tripping-lugs extend below the under side of said pawls the less will be the degree of elevation of the said teeth before being replaced in position for raking, and the less also will be the time between dumpings and between replacings. I can thus regulate, also, the distances of the gavels from one another when deposited upon the ground.

For tedding or spreading the hay the said tripping-lugs N' N' are adjusted downward sufficiently to cause a rapid alternation of dumpings and rakings, which results in turning over all the half-made hay, and exposing every part of it to the air and sunlight. Chain P is also preferably made adjustable with regard to its length by means of a hook attachment at either end. By shortening said chain the said pawls will be brought into engagement with the said ratchets whenever the said rake-teeth fall, and so the tedding will continue automatically.

The dumping of the gavels is facilitated by means of two strippers or clearing-bars, R R , through which the rake-teeth pass, and which are connected together by short metal rods r r . Said clearing-bars are hung pivotally from the rear ends of two rods or arms, S S , which are pivoted by their front ends to standards T T , rigidly secured to the front of axle A . When said rake-teeth are raised, they pass up through said clearing-bars or strippers, which strip the hay from them and deposit it in gavels.

U designates a spiral spring, which connects the top of arm Q on rock-shaft L with a rigid bar or plate, Q' , on pressure-bar I . Said spring acts to turn said shaft backward, and thus raise the said pawls from their respective ratchets.

V designates a bell-crank, pivoted on a rod, p^2 , which rod extends through two of the brackets P , near the middle of the device. The rear part of said bell-crank is connected to lifting-bar K and pressure-bar I , and its front end is connected by a downward-extending link, w , to the rear end of a lever, W , which is pivoted in frame C , and provided with a handle, W' , and a foot-piece, w' . By forcing the front end of said lever downward and forward, the rake-teeth G are held in contact with the surface of the ground, or nearly so. This allows me to entirely fill the said curved rake-teeth before dumping, so that the gavels will be quite large. By raising the front end of said lever, said teeth are elevated, and may be held out of operation as long as is desired; or this lever and connections may be employed as a substitute for the pivoted foot-bar and its connections, already described, in the ordinary operation of the apparatus.

It is sometimes (as, for instance, when raking in stubble) desirable to keep the points of the rake-teeth a little distance above the surface of the ground. To accomplish this I make use of an adjusting device, consisting of a plate, X , which has longitudinal slots x x , and is attached to the top of frame C by bolts or pins passing through said slots. This construction enables said plate to be adjusted forward or backward, so as to regulate the distance to which the front end of lever W may be depressed.

The vibration of the foot-bar hereinbefore described is limited by studs z z , placed, respectively, before and behind said foot-bar. The pivotal attachment of the strippers to their supporting-arms obviates all danger of injury resulting to the teeth or strippers from locking.

One of the said ratchet-wheels and its pawl may be dispensed with without departing from my invention; but such a construction would subject the apparatus to an uneven strain. Various other changes may also be made, and mechanical equivalents may be substituted wherever applicable.

The foot-bar may be made to slide instead of pivoting it.

What I claim as new, and desire to secure by Letters Patent, is—

1. A horse hay-rake constructed with adjustable automatic mechanism, whereby it is caused automatically to ted the hay by a rapid collecting and dumping motion, or to collect it into windrows, as desired, substantially as set forth.
2. In a hay-rake, a ratchet-wheel secured to one of the transporting-wheels, in combination with a pawl secured to a rock-shaft, and having an adjustable tripping-lug, substantially as set forth.
3. Rock-shaft L , in combination with spring U and pawl or pawls N , having adjustable lug or lugs, substantially as and for the purpose set forth.
4. Adjustable chain P , in combination with a foot-bar, rock-shaft L , and pawl or pawls N , provided with tripping-lugs, substantially as set forth.
5. In a horse hay-rake, the combination of an adjustable chain, P , with a foot-bar, a rock-shaft, L , pawls N , and ratchet-wheels E , attached to the transporting-wheels, substantially as and for the purpose set forth.

In testimony that I claim the above I have hereunto subscribed my name in the presence of two witnesses.

ROBERT WILSON.

Witnesses:

C. H. McEWEN,
JOS. B. LOOMIS.