

W. B. PARKHURST.
COP BUILDER.

No. 185,834.

Patented Jan. 2, 1877.

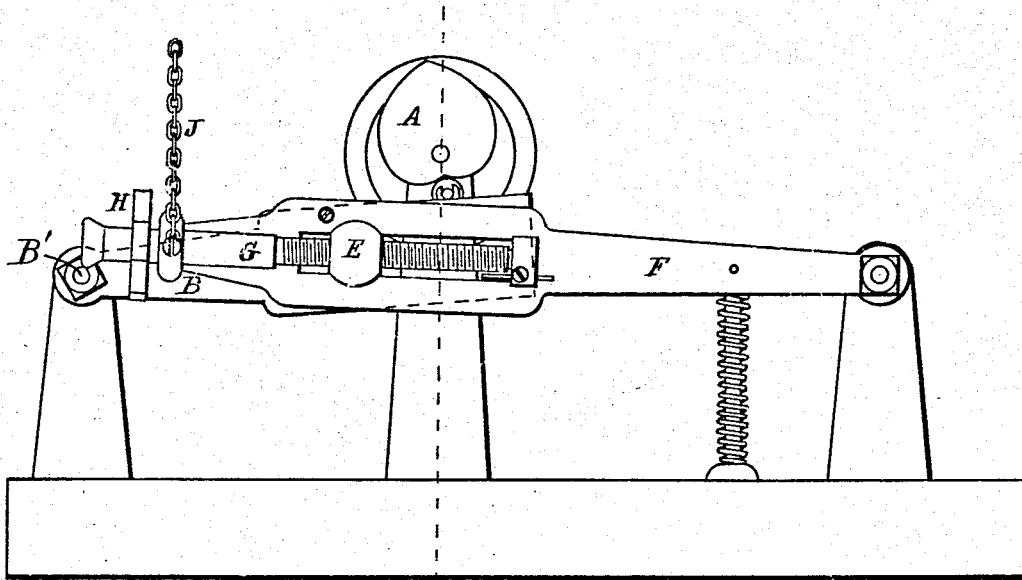

FIG. 2.

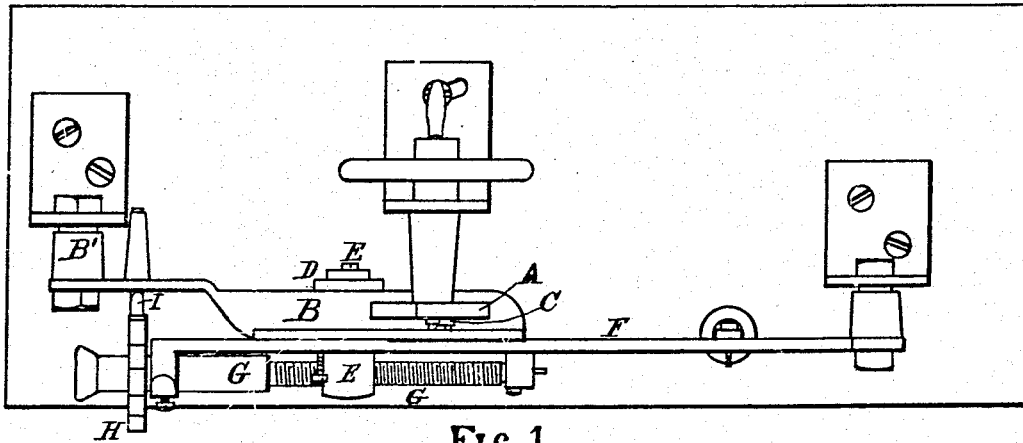

FIG. 1.

WITNESSES.

E. A. Humenway
Wm. C. Hibbard

INVENTOR.

W. B. Parkhurst

W. B. PARKHURST.
COP BUILDER.

No. 185,834.

Patented Jan. 2, 1877.

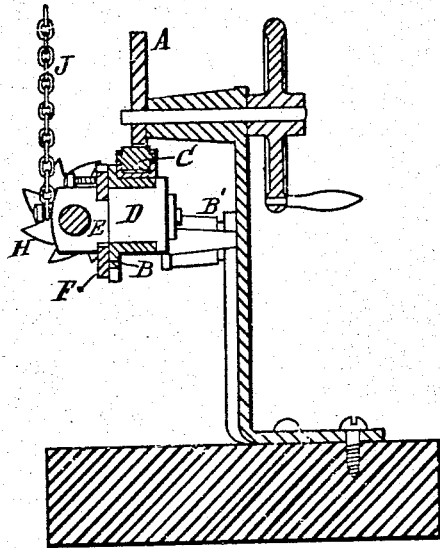

FIG. 4.

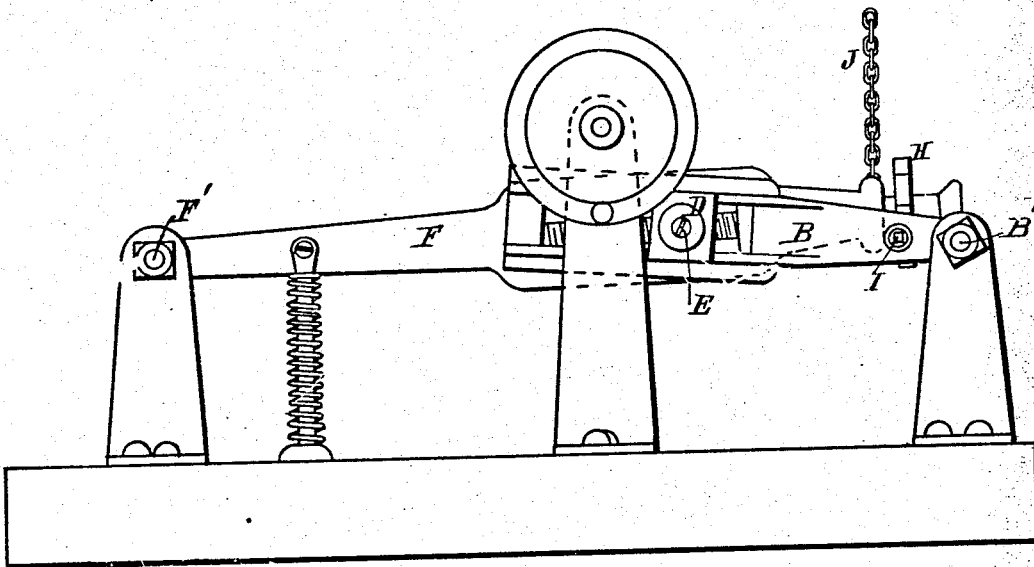

FIG. 3.

WITNESSES.

INVENTOR.

E. A. Hummerway
Wm C. Hibbard

W. B. Parkhurst

UNITED STATES PATENT OFFICE.

WILLIAM B. PARKHURST, OF NORTH ANDOVER, MASSACHUSETTS, ASSIGNOR
TO GEORGE L. DAVIS, JOHN A. WILEY, JOSEPH M. STONE, GEORGE G.
DAVIS, JOSEPH H. STONE, AND JAMES H. DAVIS, OF SAME PLACE.

IMPROVEMENT IN COP-BUILDERS.

Specification forming part of Letters Patent No. 185,834, dated January 2, 1877; application filed
January 10, 1876.

To all whom it may concern:

Be it known that I, WILLIAM B. PARKHURST, of North Andover, in the county of Essex, and State of Massachusetts, have invented an Improvement in Cop-Builders, of which the following is a specification:

My improvement relates to the construction of that part of the mechanism of a spinning-machine by which the yarn is guided, as it is wound upon the bobbin, and especially to that part of the same by which the ring or coping-rail, so-called, is operated by what is called the heart-cam, so as to build the bobbin with conical ends, the intermediate portion being cylindrical.

In mechanisms for this purpose which have been heretofore used, the movements given by the heart-cam have been imparted through the intervention of a lever, in which a sliding block was arranged to move radially, to which block the chain or its equivalent was attached, by which the ring-rail or coping-rail, as it is called, was operated, and by moving the block toward and from the fulcrum of the lever, a shorter or longer extent of movement was given to the means of guiding the yarn on to the bobbin. But in this case, the radial movement of the block along the lever to vary the traverse of the ring-rail also varied the position of the chain or other device through which the traverse motion was imparted, so much as to distort its movement, so that it required the form of the heart-cam to be also distorted, which could only partially remedy the difficulty, because the relative positions of the block at the beginning and finishing of the bobbins were so different, while the form of the cam must of necessity be constant. This difficulty is remedied by my improvement, which consists in the use of a secondary lever in combination with the lever which is directly operated by the heart-cam, which secondary lever is connected with the other lever by the sliding block, which slides in both, and to which secondary lever the chain which works the ring or coping-rail is attached in a fixed position, so that the move-

ment of the sliding block in the levers, to vary the extent of motion of the rail, does not affect the position of the chain, or require any distortion of the shape of the heart-cam, and the movement imparted by it is correct for all parts of the formation of the bobbin.

In the drawings is represented one form of the device disconnected from the rest of the spinning-machine, which will serve to show the combination and mode of operation of the parts employed.

Figure 1 is a plan. Fig. 2 is a front elevation. Fig. 3 is a back elevation; and Fig. 4 is a transverse section through the center of the heart-cam.

A is the heart-cam, arranged in any convenient manner, and operating as usual in spinning-machines, and B is a lever having its fulcrum at B', and a roller, C, which works upon the surface of the cam A, which imparts an oscillating motion to the lever in the obvious manner. This lever is made with a long radial slot or groove in it, in which is fitted a sliding block, D, in which the wrist-pin E works, which serves to connect the lever B with the secondary lever F, which works alongside of the lever B. This lever has its fulcrum at F', and is also provided with a long slot in which the wrist-pin E works, which imparts an oscillating motion to this lever. G is a screw hung in suitable bearings upon the lever F, which works in a nut in the wrist-pin E, as shown, and serves to slide the wrist-pin and block D back and forth in the slots in the levers. By this means the range of motion of the lever F may be varied, while the motion of the lever B is constant.

Upon the outer end of the screw G is fixed a ratchet, H, with a suitable number of teeth, which is operated by a spring-pawl, I, which is attached to the other lever B, or some other part of the machine, which turns the ratchet one tooth at each vibration of the levers, as it moves past the pawl, and this turns the screw a certain distance at each traverse of the coping-rail, corresponding to the shortening of the traverse required for the proper building

of the bobbin. J is the chain which leads to the mechanism which carries the ring or coping-rail in any usual way.

This method of combining the heart-cam, levers, chain, and sliding connection of the levers, to graduate the movement of the ring or coping-rail, may be put in various forms, such as will best accommodate the construction of other parts of a spinning-machine, but the form especially shown and represented is believed to be a full embodiment of the principle and mode of operation of my invention.

What I claim is—

1. The combination of the heart-cam, the primary lever, the secondary lever, with the chain attached thereto in a fixed position, and

the sliding connection of the two levers, substantially as described.

2. The secondary lever having the chain or other equivalent means for imparting motion to the coping-rail or device for guiding the yarn onto the bobbin, attached to said lever in a fixed position, and a wrist-pin sliding radially therein for imparting a variable motion to said lever, co-operating substantially as described.

Executed January 4th, A. D. 1876.

WM. B. PARKHURST.

Witnesses:

E. A. HEMMENWAY,
WM. C. HIBBARD.