

J. H. GILL.

CARTRIDGE WEIGHING MACHINE.

No. 185,858.

Patented Jan. 2, 1877.

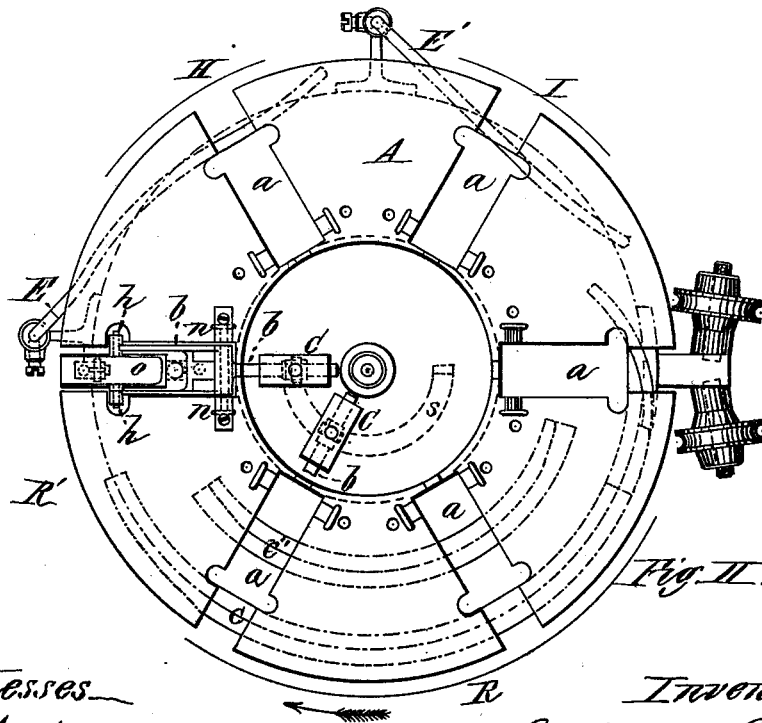
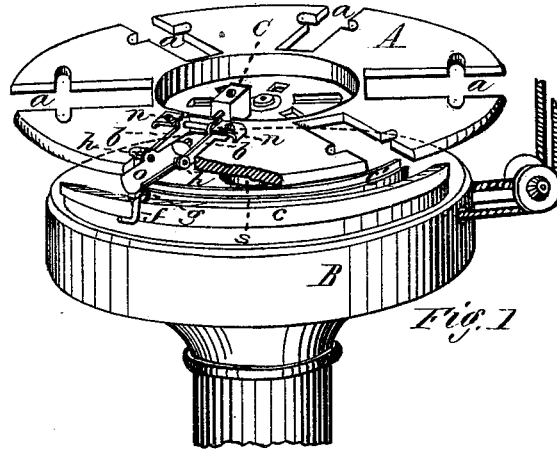

Witnesses  
E. H. Blandin  
D. E. Fisk

Inventor,  
J. H. Gill.  
By T. A. Leavitt,  
his Atty.

J. H. GILL.

CARTRIDGE WEIGHING MACHINE.

No. 185,858.

Patented Jan. 2, 1877.

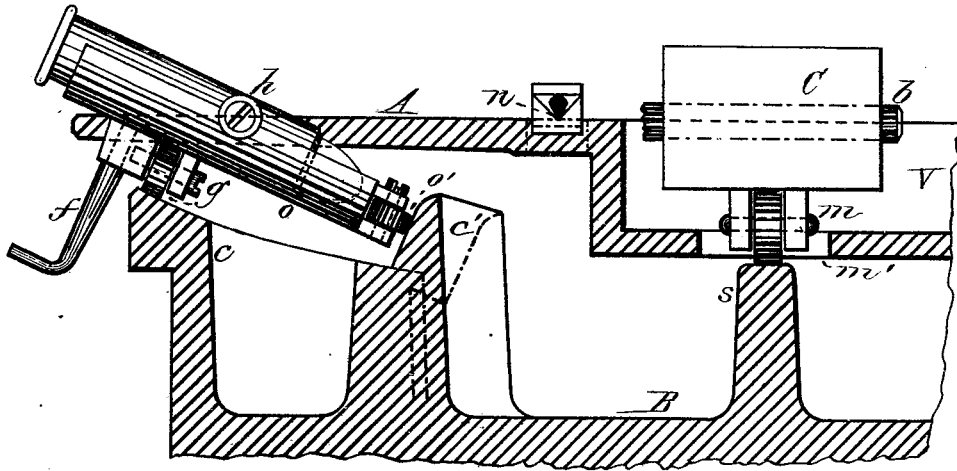

Fig. IV.

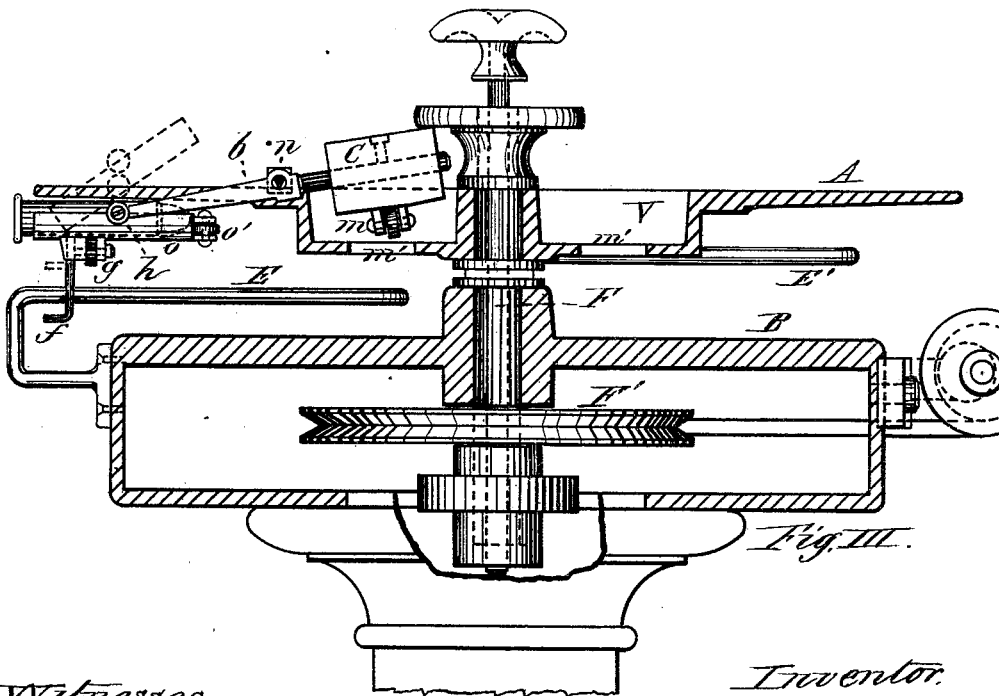

Fig. III.

Witnesses  
S. N. Olander  
D. E. Fisk.

Inventor.  
Jabez H. Gill  
By T. A. Luntz  
his Atty.

# UNITED STATES PATENT OFFICE.

JABEZ H. GILL, OF PHILADELPHIA, PENNSYLVANIA.

## IMPROVEMENT IN CARTRIDGE-WEIGHING MACHINES.

Specification forming part of Letters Patent No. **185,858**, dated January 2, 1877; application filed November 3, 1876.

*To all whom it may concern:*

Be it known that I, JABEZ H. GILL, of Philadelphia, in the State of Pennsylvania, have invented a new and useful Improved Machine for Weighing Cartridges; and that the following is a full, clear, and exact description thereof, reference being had to the accompanying drawings, making a part of this specification, and to the letters of reference marked thereon.

The object of my invention is to separate those cartridges which have too little powder in them from those which have sufficient, and throw them to one side. To this end my invention consists of a revolving disk, supported upon a base provided with guiding ways or tracks; said disk being supplied with any desired number of weighing-scales, the trays of which are tilted by suitable mechanism at the desired point, whereby those shells which contain too little powder are deposited in one place, and those containing a sufficient quantity are deposited in another place, all which will be more fully hereinafter explained.

Figure I is a perspective view of my invention. Fig. II is a plan view of the same. Fig. III is a vertical central section of the same; and Fig. IV is a vertical section, showing the details of the weighing-scales, and the guiding-ways or tracks which operate the scale.

In the drawings, B represents a base, which may be hollow, and perforated to receive the pivot or spindle F, to the lower end of which may be secured a pulley, F', with the disk A secured to the upper end. This disk is provided with any desired number of recesses, *a*, to receive the scales or balances N, which consist of the forked beam *b*, upon the inner end of which is placed the counterpoise C, made adjustable thereon, either toward or from the pivot *n*, upon which the beam is balanced, and which pivot should have a knife-edge on the lower side, as shown in Fig. III, that it may be sufficiently delicate in its movements. Nicely balanced upon trunnions or pivots *h*, at the forked end of the beam *b*, is the pan or tray *o*, with a trip or projecting piece, *f*, on its lower side; and a small wheel, *g*, may also be attached thereto, near the trip, and also one at the inner end of the tray, at *o'*; and another similar wheel may be attached to the

lower side of the counterpoise C, to permit the tray and counterpoise to ride around freely upon their tracks made upon the base B of the machine, as shown at *c c'* and *s* in Figs. II and IV. These tracks are made only partially around the base, as shown in dotted lines in Fig. II, and are beveled at their ends to permit the tray and counterpoise to ride gently from and upon them. The track *c*, which extends around beneath the outer end of the tray, is somewhat higher than the track *c'*, beneath the inner end of the tray, as seen clearly in Fig. IV, and the tray assumes a tilted position, as seen in Fig. IV, after riding up over the beveled ends of these tracks. Apertures *m'* are made in the disk, beneath the counterpoise, so that a projection upon the latter, at *m*, or the wheel attached thereto, may protrude through and bear upon the track *s*, when the scale is passing around to receive the shell, to hold the scale in a proper horizontal position, and when the tray is empty the counterpoise may rest upon the bottom of the central recess V of the disk, to prevent any unnecessary movement of the scale.

The operation of my invention is as follows: The disk A, which may be provided with any desired number of scales, as indicated by the recesses *a*, is given a rotary motion in the direction indicated by the arrow, by a belt passing around the pulley F', or by any other suitable means, and as the scale N in each recess rides up on to the tracks *c* and *c'*, or at any point in the length of the line R, in Fig. II, the shell, with the proper quantity of powder therein, is placed in the tray *o*, and, with the counterpoise C, adjusted on the inner end of the beam *b*, so that the minimum quantity of powder required in the shell will just overbalance the counterpoise C. As the disk A rotates, with the shell in the tray, as long as the latter rides upon the tracks *c* and *c'*, it maintains a tilted position, as shown in Fig. IV; but when each scale arrives at the point R', or passes off the tracks, it assumes a position shown in Fig. III, and as it passes around the projection *f* strikes against the tripping-grade E, and the tray is thereby tilted, and the shell thrown out at the point H. If, on the other hand, an insufficient

quantity of powder is placed in the shell, when it arrives at the point R' the weight of the powder and shell will not be sufficient to over-balance the counterpoise, and the scale, instead of falling, maintains its horizontal position, or even slightly rises at the tray end, and the projection *f* passes along above the grade E, and on reaching the tripping-grade E' strikes against that, which is higher, as shown in Fig. III, and the tray is tilted, and the shell thrown out at I.

It will thus be seen that a shell which contains less than the required minimum quantity of powder is thrown out at one point, and separated from those which contain the minimum quantity, which are thrown into a place by themselves.

It will be observed that the tray *o*, when free from the tracks *c* and *c'*, always assumes a horizontal position, whether that end of the beam rises or falls, being nicely balanced upon the trunnions or pivots *h* for that purpose.

It is obvious that the disk may be made of any size, and may be provided with any desired number of scales, and may be made to rotate by any desired means.

Having thus described my invention, what I claim as new is—

1. The combination of the horizontally-rotating disk A with the weighing-scales N, the guiding-tracks *c*, *c'*, and *s*, and the tripping mechanism for tilting the tray and throwing the shell from the scales, substantially as described.

2. In a cartridge-weighing machine, the combination of the balancing-beam *b*, the counterpoise C, made adjustable thereon, and the pivoted balanced tray *o*, substantially as set forth.

JABEZ H. GILL.

Witnesses:

HENRY WERNLE,  
MATTHEW McBRIDE.