

G. F. BLAKE.  
DUPLEX PUMPING ENGINE.

No. 185,888.

Patented Jan. 2, 1877.

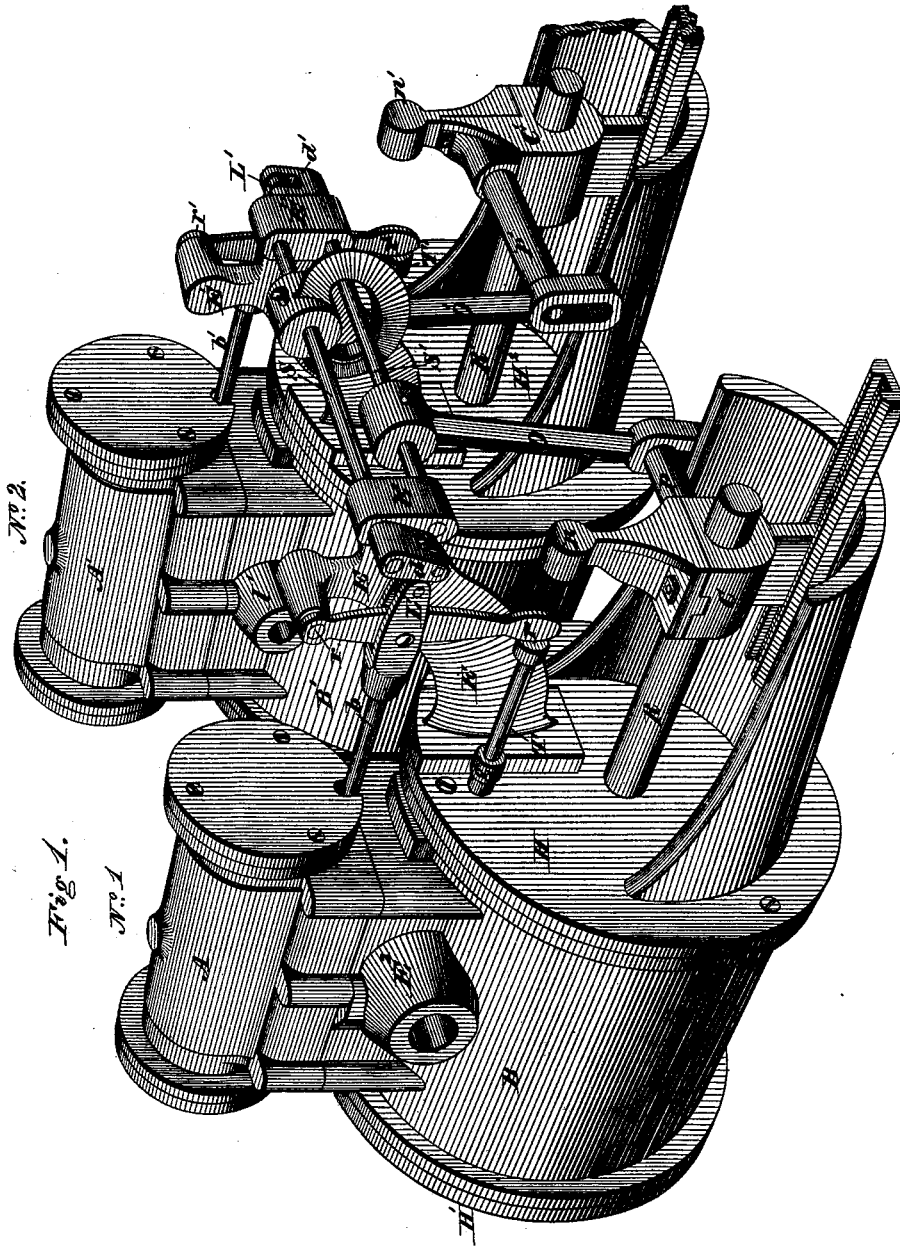

WITNESSES  
*Harry King*  
*D. P. Cow*

INVENTOR  
*George F. Blake*  
By his Attorneys  
*Stansbury & Munn.*

G. F. BLAKE.  
DUPLEX PUMPING ENGINE.

No. 185,888.

Patented Jan. 2, 1877.

Fig 2.

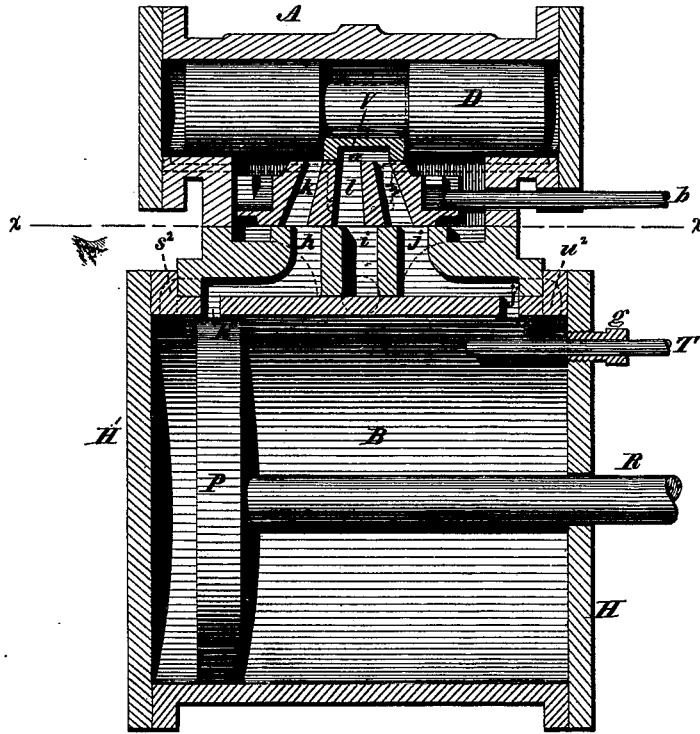
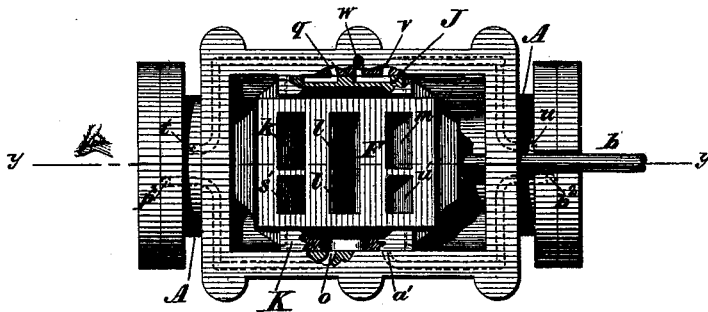

Fig 3.



WITNESSES  
*Harry King*  
*A. P. Cowl*

By his Attorney

INVENTOR  
*George F. Blake,*  
*Stansbury & Munn.*

G. F. BLAKE.  
DUPLEX PUMPING ENGINE.

No. 185,888.

Patented Jan. 2, 1877.

Fig 4.

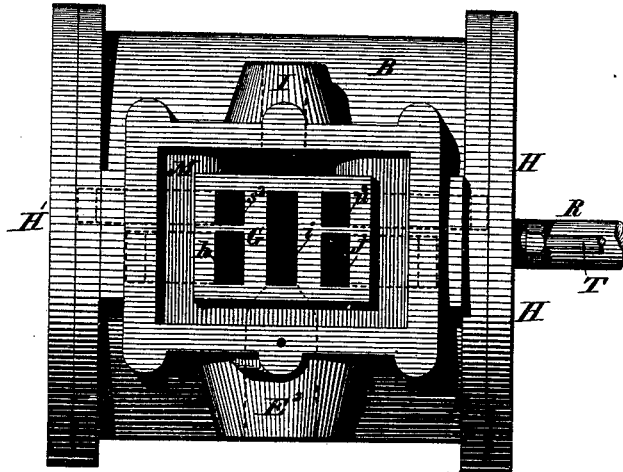

Fig 5.

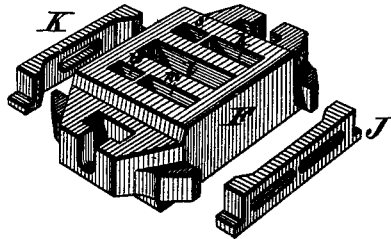
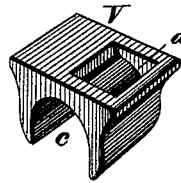

Fig 6.



WITNESSES

*Harry King*  
*D. P. Howl.*

INVENTOR

*George F. Blake,*  
By *his Attorneys*  
*Stansbury & Munn.*

# UNITED STATES PATENT OFFICE.

GEORGE F. BLAKE, OF BOSTON, MASSACHUSETTS, ASSIGNOR TO GEORGE F. BLAKE MANUFACTURING COMPANY, OF SAME PLACE.

## IMPROVEMENT IN DUPLEX PUMPING-ENGINES.

Specification forming part of Letters Patent No. 185,888, dated January 2, 1877; application filed May 17, 1876.

*To all whom it may concern:*

Be it known that I, GEORGE F. BLAKE, of Boston, in the State of Massachusetts, have invented certain Improvements in Duplex Pumping-Engines; and I do hereby declare the following to be a full and correct description of the same, reference being had to the accompanying drawings, in which—

Figure 1 is a perspective view of my duplex pumping-engine. Fig. 2 is a vertical section of the main and auxiliary cylinders and their connections. Fig. 3 is a sectional view on line *z z* of Fig. 2, looking upward. Fig. 4 is a top view of the main valve-seat. Fig. 5 is a perspective view of the movable seat and side valves. Fig. 6 is an inverted view of the main valve.

The same letter marks the same part wherever it occurs in the drawings.

Where large quantities of water have to be continually raised or supplied by pumping, as in the water-works of towns and cities, and in the clearing of mines, it is usual to employ duplex pumps, which, by the alternation of their strokes, keep up a continuous flow of water through the pipes, thus obviating those destructive concussions and shocks, which would occur if a single pump only were employed.

The object of my invention is to provide a mode of relieving a difficulty which often occurs in the use of duplex pumping-engines—viz., the stoppage of the entire water-supply on account of an injury to one of the pumps or engines.

My improvements offer the greatest possible security against an occurrence of this kind, since where they are applied, while either pump or either engine remains in working order, the supply of water cannot be wholly cut off.

The nature of my invention consists in the combination and arrangement, for joint or separate action, of two pumping-engines, each capable of working as an independent engine, and the two, when coupled for joint operation, being so arranged that each engine shall actuate its own valves, either separately or together with the valves governing the motive power of the other, so that the two engines

shall operate in perfect unison when working together, and that either of them may be stopped for repairs without arresting the operation of the other.

Fig. 1 of the drawings represents two direct-acting pumping-engines, marked No. 1 and No. 2, each constructed mainly in accordance with patents heretofore granted to me. Each engine has an auxiliary cylinder, A, in which reciprocates a piston or plunger, P, which operates the main steam-valve V. The inlet and exhaust of this cylinder A are controlled by valves operated by slide-rod *b*, operated by a lever, *r*, receiving motion from a tappet-rod, T, impelled by the piston of the main cylinder B, and by tappet-arm *n*, attached to the top of the cross-head C on the end of piston-rod R. A bracket, E, attached to head H of the cylinder B of engine No. 1, serves as a point of attachment for the fulcrum of lever *r*, and also affords a bearing for two rocker-shafts, S S'. The opposite ends of these rocker-shafts are supported in bearings in bracket E', attached to the head H<sup>2</sup> of the cylinder of No. 2. Rock-shaft S has on one end an arm, *d*, attached by a link, L, to valve-rod *b*, and near its other end an arm, O', which receives vibrating motion from a pin, *p*<sup>1</sup>, attached to the cross-head C' of engine No. 2. It follows that the reciprocation of cross-head C' imparts vibration to rock-shaft S, and thus operates, by means of rod *b*, the valves which control the movements of engine No. 1. Rock-shaft S' has an arm, *d*', attached by a link, L', to rod *b*<sup>1</sup>, and, near its other end, an arm, O, which is vibrated by pin *p*, fixed in cross-head C of engine No. 1. Thus the reciprocation of head C rocks shaft S', and operates the rod *b*<sup>1</sup>, by which the valves controlling the movements of engine No. 2 are driven.

When the engines are coupled in this manner for joint operation, the tappet-bars T T' are removed. The holes in which they work are covered by caps screwed onto them, and the levers *r r'* are disconnected, or the tappet-arms *n n'* removed from their respective cross-heads.

When it is desired that one engine, as No. 1, should work its own valves and move the valves of the opposite engine, No. 2, the link L is disconnected from rock-shaft S. When that

arrangement is made, engine No. 1 works its own valves by means of the tappet T and tappet-arm *n*, operating lever *r* and rod *b*, and at the same time works the valves of engine No. 2 by means of rock-shaft S', driven by pin *p*. A converse arrangement enables engine No. 2 to work its own valves, and also those of No. 1.

When it is desired that each or either engine shall act independently, the links L and L' are to be disconnected from the rocker-shafts S and S', respectively; or, if preferred, the levers O O' may be disconnected from the pins *p p'* and their respective cross-heads. In either case the tappet-rods T are again inserted and the tappet-arms *n* replaced.

The tappet-rod T passes through a gland, *g*, into the main cylinder B, (see Fig. 2,) and is driven out by the piston P as it approaches the end of its forward stroke.

The operation of the main and auxiliary valves does not differ essentially from that described in my previous patents, and in an application of even date herewith for an improvement in steam-pumps.

Above the main cylinder is placed an auxiliary cylinder, A, in which works a plunger-piston, D, which is driven by steam, and works the main valve V. This valve rests on the movable seat F, which slides upon the fixed valve-seat G. The cylinder A, in which plunger D works, takes steam and exhausts through ports and steamways controlled by the side valves J K, placed in lateral recesses in the movable seat F. These steamways are shown in dotted lines in Figs. 2 and 3.

In Fig. 3 cylinder A is shown taking steam through ports *o p<sup>2</sup> q t*, and exhausting through ports *u v w*. The port *b<sup>2</sup>* being nearer to the end of cylinder A than port *u*, the steam between the two is trapped by reason of port *a'* being closed by the face of valve K. The reverse throw of the valve produces a converse condition of the ports and steamways, the cylinder A taking steam through ports *v u a' b<sup>2</sup>*, and exhausting through ports *t w*, the plunger cushioning on steam trapped between ports *t* and *b<sup>2</sup>* by valve K closing port *o*.

The main valve V controls the ports in the movable and fixed valve-seats F and G, so that the main cylinder B shall, in the position shown in Fig. 2, take steam through ports *k h h' s<sup>1</sup> s<sup>2</sup>*, exhaust-ports *j' j m a l i*, and the piston at either end of its stroke cushion on steam trapped between ports *h'* and *s<sup>2</sup>*, or *j'* and *u<sup>2</sup>*, by reason of ports *s<sup>1</sup> u<sup>1</sup>* being alternately covered by the plain surface of valve V.

The only part of this valve mechanism which is not shown in my previous patents is that for controlling the inlet and exhaust of the plunger-piston D.

Having thus fully described my invention, what I claim, and desire to secure by Letters Patent, is—

1. The combination and arrangement for joint or separate action of two pumping-engines, each being capable, by means substantially as shown, of working as an independent engine, and, when coupled, either engine being capable of operating its own valves and those of the engine to which it is joined, substantially in the manner and for the purpose described.

2. In combination with two pumping-engines, each capable of independent action, the coupling mechanism consisting of the pins *p p'*, levers O O', rocker-shafts S S', arms *d d'*, links L L', and valve-rods *b b'*, all constructed, arranged, and operating substantially in the manner specified.

3. In combination with the movable valve-seat F, the side valves J and K, and the system of ports controlled by them, to operate the piston D of the auxiliary engine, all constructed and arranged substantially as set forth.

The above specification of my said invention signed and witnessed, at Washington, this 15th day of May, A. D. 1876.

GEO. F. BLAKE.

Witnesses:

HARRY KING,  
CHAS. F. STANSBURY.