

J. A. ENO.
RAILROAD RAIL-JOINT.

No. 185,901.

Patented Jan. 2, 1877.

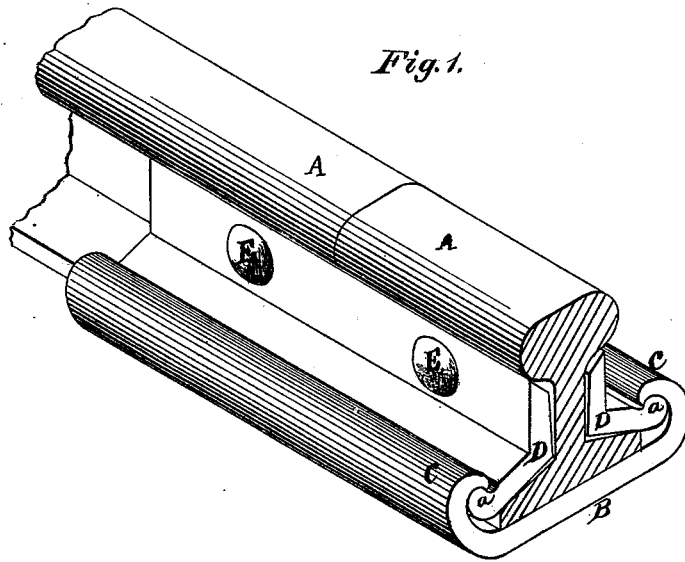
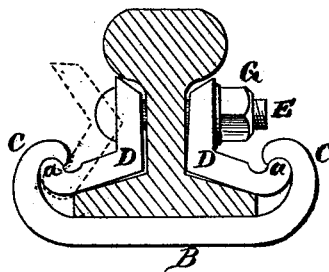

Fig. 2.



WITNESSES

Henry N. Miller,
F. L. Curand

INVENTOR

Joseph A. Eno,
By *Alexander Mason*
Attorneys.

UNITED STATES PATENT OFFICE.

JOSEPH A. ENO, OF COUNCIL BLUFFS, IOWA, ASSIGNOR OF ONE-EIGHTH OF HIS RIGHT TO ALEXANDER MCKIRGAN, OF NEWARK, NEW JERSEY.

IMPROVEMENT IN RAILROAD-RAIL JOINTS.

Specification forming part of Letters Patent No. **185,901**, dated January 2, 1877; application filed June 13, 1876.

To all whom it may concern:

Be it known that I, JOSEPH A. ENO, of Council Bluffs, in the county of Pottawatomie and in the State of Iowa, have invented certain new and useful Improvements in Railroad-Rail Joints; and do hereby declare that the following is a full, clear, and exact description thereof, reference being had to the accompanying drawings, and to the letters of reference marked thereon, making a part of this specification.

The nature of my invention consists in the construction and arrangement of a railroad-joint fastening, as will be hereinafter more fully set forth.

In order to enable others skilled in the art to which my invention appertains to make and use the same, I will now proceed to describe its construction and operation, referring to the annexed drawing, in which—

Figure 1 is a perspective view of my invention, and Fig. 2 is an end view of the same.

A A represent the ends of two adjoining railroad-rails, which are fastened together by the following means: B is a plate forming the base of the fastening. This plate is placed under the foot of the rail, and has its side edges curved upward and inward, as shown at *c c*. On each side of the rail is a fish-plate, D, made in angular form, as shown, to fit against the side of the rail, and also on top of the foot thereof. The outer edge of the fish-plate is turned upward, forming a bead, *a*, which fits under the upturned edges C of

the base-plate B. Bolts E are then passed through the fish-plates and rails, and fastened by nuts G.

This fastening is very simple, cheaply and easily manufactured, and is strong and durable.

It will be seen that the upturned edges C of the plate B form hooks, which extend beyond the base of the rail on each side. By this construction of the fish-plates D and plate B the former can be readily detached or attached sidewise from the rail, as indicated in dotted lines in Fig. 2.

It will further be seen that with my invention the base of the rail is rested upon the chair or plate B, and the compression of the fish-plates is produced wholly by the bolts and nuts against the elastic action of the chair.

Having thus fully described my invention, what I claim as new, and desire to secure by Letters Patent, is—

The combination of the plate B, having enlarged curved upturned side edges C C, forming hooks, and the fish-plates D D, having rounded beads *a* along their outer edges, with the bolt E and nuts G, substantially as and for the purposes herein set forth.

In testimony that I claim the foregoing I have hereunto set my hand this 9th day of June, 1876.

JOSEPH A. ENO.

Witnesses:

WM. L. BRAMHALL,
M. L. STOWELL.