

J. H. POWERS.

CRIB.

No. 185,960.

Patented Jan. 2, 1877.

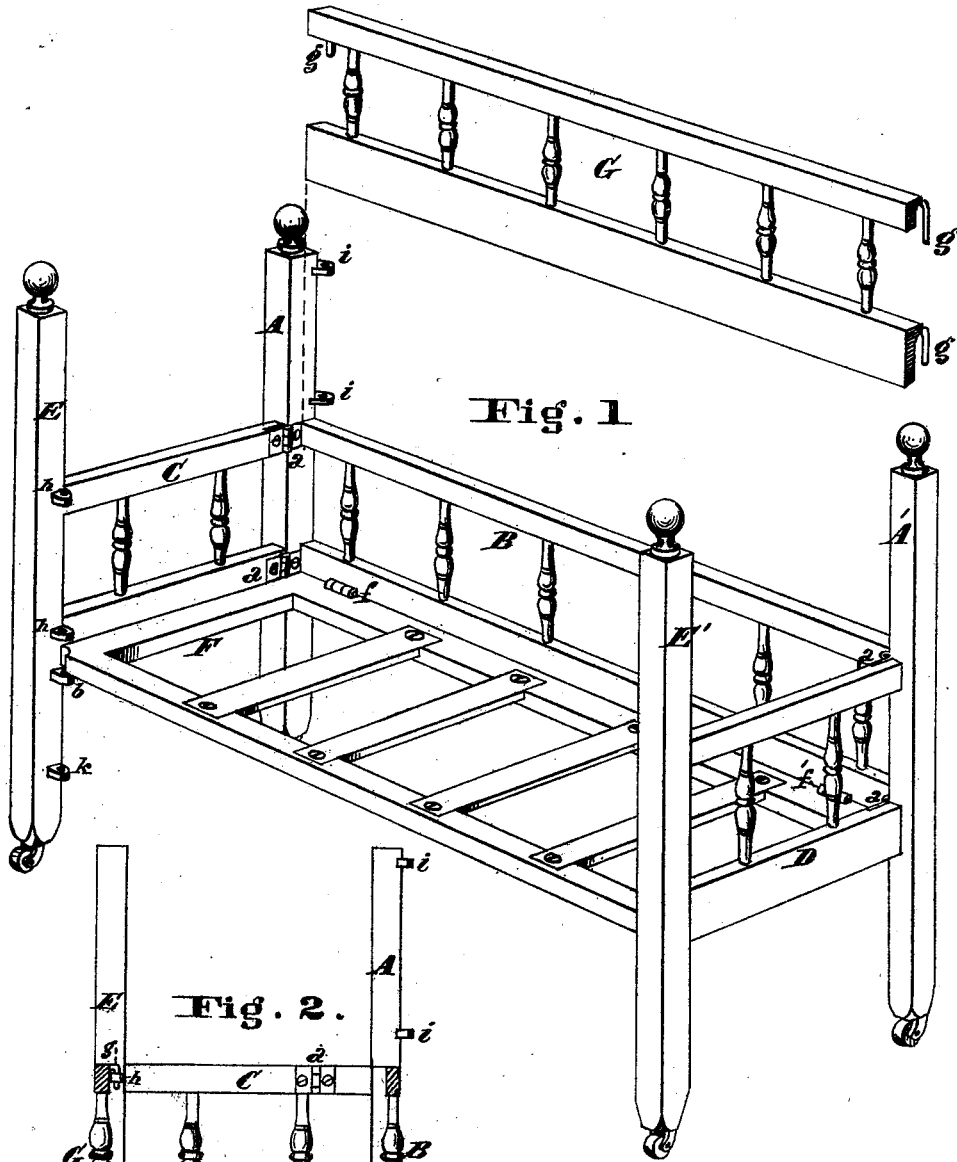

Fig. 1.

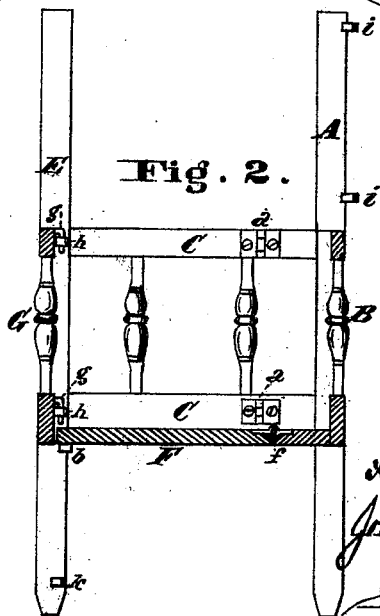

Fig. 2.

Inventor  
J. H. Powers  
Attest John Jones By F. Millward  
Edgar J. Cross Attorney

# UNITED STATES PATENT OFFICE.

JOHN HALE POWERS, OF CINCINNATI, OHIO.

## IMPROVEMENT IN CRIBS.

Specification forming part of Letters Patent No. **185,960**, dated January 2, 1877; application filed December 8, 1876.

*To all whom it may concern :*

Be it known that I, JOHN HALE POWERS, of Cincinnati, Hamilton county, State of Ohio, have invented an Improvement in Cribs, of which the following is a specification :

My invention is designed to enable a crib, after each night's use, to be conveniently and compactly folded together, so that it can be placed in a closet or otherwise disposed of, and not occupy space desirably open during the day; and my invention consists, in the first part, of a crib so proportioned and connected together that one of its sides can be removed, and, if desirable, be placed directly over and in the same plane with the other side, the bottom be folded up against these two sides, and the ends both folded compactly in against the bottom, the whole then occupying a space of not necessarily more than four feet long, four inches thick, and three or four feet high; and, when preferred, one of the modifications of my invention may consist in locating the hinges of the bottom and ends a short distance from the inside face of the permanent side, so as to leave a space between the bottom, when folded up, and this inside vertical face sufficient to stow away the clothes of the crib.

My invention consists, in the second part, in such a construction of the crib that it may conveniently be changed into a settee.

In the accompanying drawings, Figure 1 is a perspective view of the crib, with the detachable side removed and shown in position immediately over that occupied by it when the crib is folded up. Fig. 2 is a cross-section of the crib when so modified as to leave a space for clothes when folded up.

A A' are the posts, to which the permanent side B is secured in the ordinary way, as shown. The ends C D are secured firmly to the posts E E', which swing inward with the sides and come close together when folded, the sides being hinged to the posts A A' at *a*. The bottom F, when down, rests on a lug or batten, *b*, at each end, and is hinged to the permanent side at *f f'*. The detachable side G is provided with one or two hasps or pins, *g*, at each end, which fit into corresponding eyes *h* on the bed-posts when the detachable

side is in place to form a crib. This side, when the bed is to be folded up, is placed so that its pins *g* will fit into the eyes *i* in the posts A A', and it may, when it is desired to convert the crib into a settee, be placed so that its upper pins will fit the lower set of the eyes *h*, and its lower pins fit into the eyes *K* on the posts E E'. In this position this detachable side holds the ends C D E E' firmly against the bottom F, and this side forms the front of the settee. Fig. 2 shows the modified form, which provides a place for packing clothes within the folded crib. The change is simply effected by removing the hinges *a f f'* back sufficiently to give a space for clothes between the bottom F and the inside face of the side B when the bottom is folded up, and still permit the ends C D to fold in against the upturned bottom, the hinges *a* being the thickness of bottom F farther away from posts A A' than the hinges *f f'*.

As a modification of the detachable side G, it may be hinged to the bottom F at its lower edge, and folded over the bottom and up with it, and still occupy the same place above the side B as it would if constructed and attached as shown in Fig. 1, except that it would be upside down. In this case the bottom should be of a width equal to the combined height of the two sides. Casters may be used on the bottom of the posts, or rockers may, of course, be employed.

I claim—

1. A crib having its ends and bottom hinged to a permanent side, and one of its sides detachable or folding, substantially as and for the purpose specified.

2. The combination of side A A' B, ends C D E E', bottom F, eyes *h k*, and detachable side G *g*, whereby the structure may be converted from a crib into a settee, substantially as described.

In testimony of which invention I hereunto set my hand.

JOHN HALE POWERS.

Witnesses:

JOHN E. JONES,  
J. L. WARTMANN.