

G. A. RICHARDS.
 VEHICLE SPRING.

No. 185,968.

Patented Jan. 2, 1877.

Fig. 1.

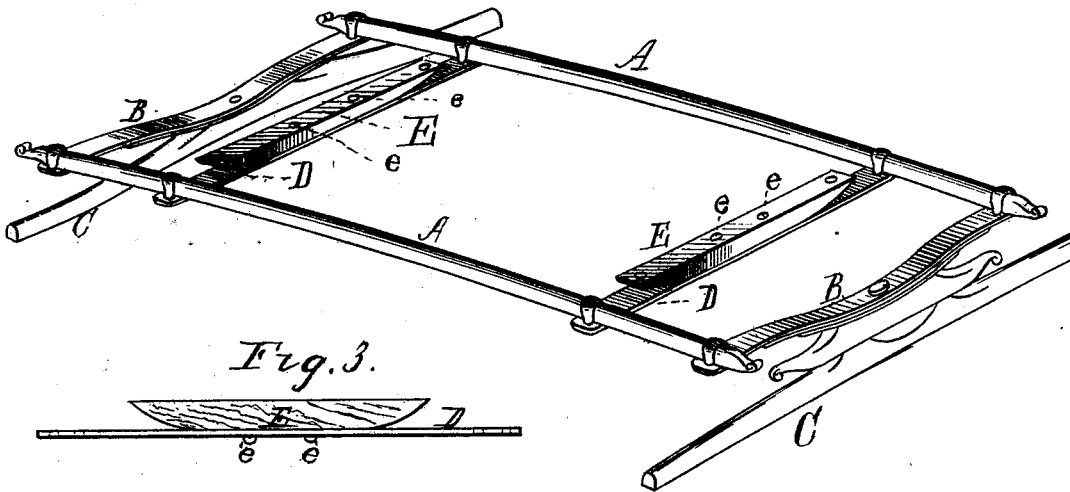
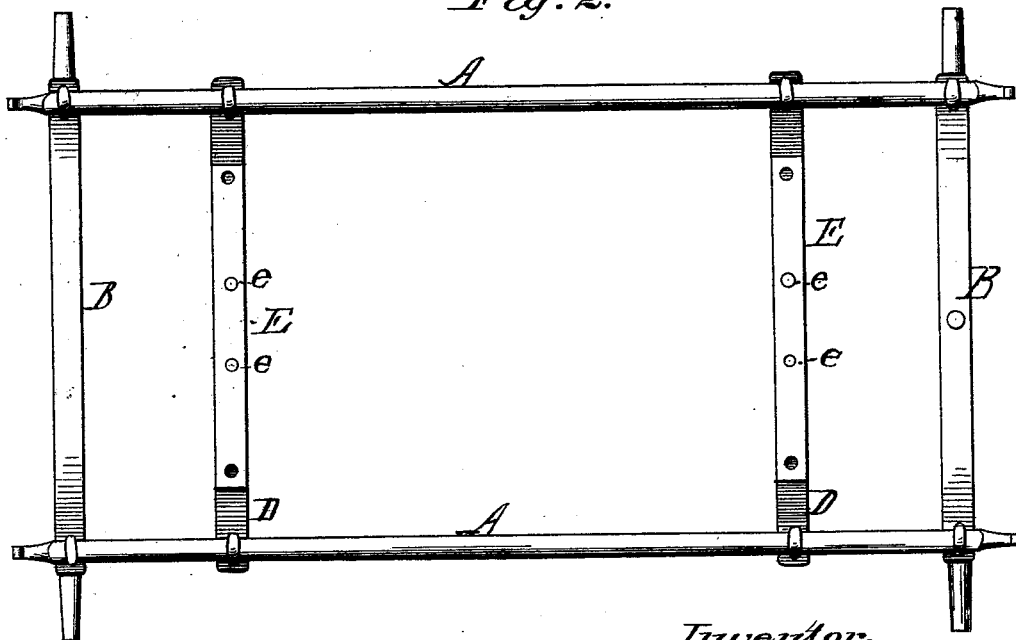

Fig. 3.



Fig. 2.



Witnesses:
 Wm. Clark Jr.
 H. C. Gill.

Inventor.
 Geo. A. Richards
 G. S. Somers & Co.
 Attorneys.

UNITED STATES PATENT OFFICE

GEORGE A. RICHARDS, OF NEW LONDON, CONNECTICUT, ASSIGNOR TO
HIMSELF AND SELDEN A. BAILEY, OF WOONSOCKET, R. I.

IMPROVEMENT IN VEHICLE-SPRINGS.

Specification forming part of Letters Patent No. **185,968**, dated January 2, 1877; application filed
July 28, 1876.

To all whom it may concern:

Be it known that I, GEORGE A. RICHARDS, of the city of New London, in the county of New London, and in the State of Connecticut, have invented a new and useful Improvement in Carriage-Springs; and I do hereby declare that the following is a full, clear, and exact description thereof, reference being had to the annexed drawings, making part of this specification, in which—

Figure 1 is a perspective view of so much of the running-gear of a vehicle as it is necessary to show for an illustration of my invention. Fig. 2 is a plan of the same. Fig. 3 is an elevation of one of the cross-bars and rockers for connecting the body of the vehicle to the side bars.

The same letters of reference are used in all the figures in the designation of identical parts.

This invention relates to what are termed "side-bar vehicles;" and consists in connecting the body of such vehicles to the side bars by means of rockers secured upon metallic cross-bars clipped to the side bars, the metallic cross-bars, whether made of iron or steel, possessing some elasticity, which, in connection with the rockers, will provide for a pleasant slight rolling or swaying motion of the body on the side bars.

To enable those skilled to make and use my invention, I will proceed to describe in detail its construction and operation.

The parallel side bars A A are, near their ends, secured to the transverse springs B B, which are attached to or connected with the axles C C in the ordinary manner. The metallic cross-bars D D are clipped or otherwise fastened to the side bars at some little distance from the springs and axles.

These cross-bars may be made either of iron

or steel, care being taken to make them thin enough, so that they may yield slightly under the load of the body, and in response to the jolts to which the vehicle may be subjected.

The cross bars carry on their upper sides rockers E E, made straight on the top side, but curved at the bottom side in a longitudinal direction. Each rocker is firmly secured to its respective cross-bar by a couple of bolts, *e e*, near the center, as clearly shown. The vehicle-body (not shown) will be firmly secured upon the rockers E E, which may be made of wood.

In the use of these rockers, resting upon the horizontal or plain metallic cross-bars, a lateral rolling motion is imparted to the body of the vehicle, which renders the same more agreeable to the rider, and, to all intents and purposes, practically adds to the elasticity of the springs. Moreover, the straight cross-bars can be made cheaper than the semi-elliptic or curved spring, which is necessary when the rockers are not used.

The direct vertical movement of the carriage-body is derived from the springs supporting the side bars and the lateral springing of the side bars, in connection with the bending of the cross-bars.

What I claim as my invention, and desire to secure by Letters Patent, is—

The combination of the rockers imparting a lateral rolling motion to the vehicle-body, the side bars, the springs supporting the latter, and the cross-bars attached to the side bars and supporting the rockers, substantially as described.

GEO. A. RICHARDS.

Witnesses:

AUGUSTUS BRANDEGEE,
E. F. MORGAN.