

A. G. BELL.
ELECTRIC TELEGRAPHY.

Patented Jan. 30, 1877.

No. 186,787.

Fig. 1.

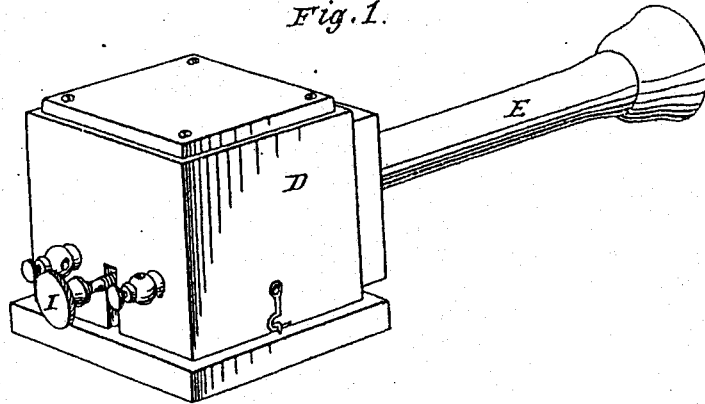

Fig. 2.

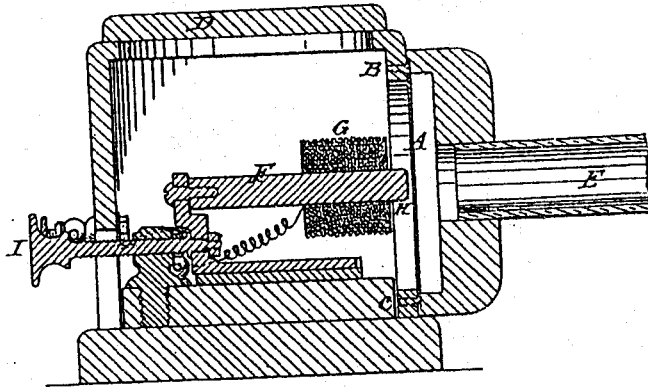
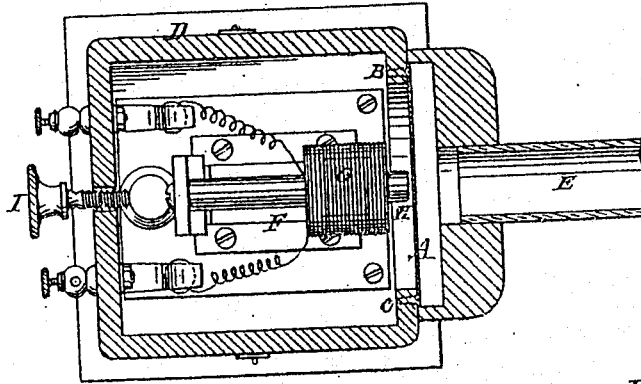

Fig. 3.



Attest
A. H. Hall
Civil Engineer

Inventor:
Alexander Graham Bell

A. G. BELL.
ELECTRIC TELEGRAPHY.

Patented Jan. 30, 1877.

No. 186,787.

Fig. 4.

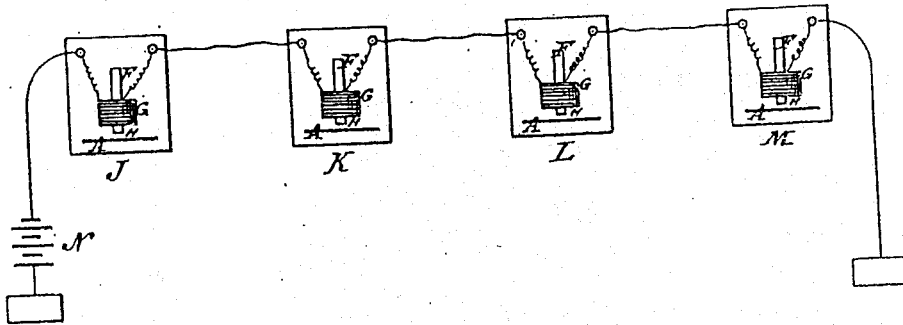

Fig. 5.

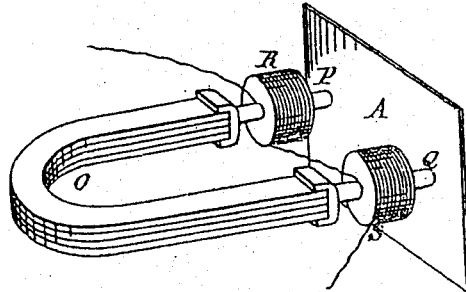
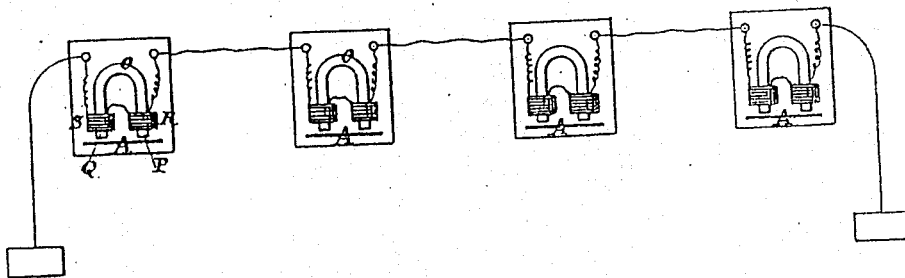

Fig. 6.



Attest:
A. Pollok
 Esq. Clerk.

Inventor:
 Alexander Graham Bell

UNITED STATES PATENT OFFICE.

ALEXANDER GRAHAM BELL, OF BOSTON, MASSACHUSETTS.

IMPROVEMENT IN ELECTRIC TELEGRAPHY.

Specification forming part of Letters Patent No. 186,787, dated January 30, 1877; application filed January 15, 1877.

U whom it may concern:

Be it known that I, ALEXANDER GRAHAM BELL, of Boston, Massachusetts, have invented certain new and useful Improvements in Electric Telephony, of which the following is a specification:

In Letters Patent granted to me on the 6th day of April, 1875, No. 161,739, and in an application for Letters Patent of the United States now pending, I have described a method of an apparatus for producing musical tones by the action of a rapidly-interrupted electrical current, whereby a number of telegraphic signals can be sent simultaneously along a single circuit.

In another application for Letters Patent now pending in the United States Patent Office I have described a method of, and apparatus for, inducing an intermittent current of electricity upon a line-wire, whereby musical tones can be produced, and a number of telegraphic signals be sent simultaneously over the same circuit, in either or in both directions; and in Letters Patent granted to me March 7, 1876, No. 174,465, I have shown and described a method of an apparatus for producing musical tones by the action of undulatory currents of electricity, whereby a number of telegraphic signals can be sent simultaneously over the same circuit, in either or in both directions, and a single battery be used for the whole circuit.

In the applications and patents above referred to, signals are transmitted simultaneously along a single wire by the employment of transmitting instruments, each of which occasions a succession of electrical impulses differing in rate from the others, and are received without confusion by means of receiving-instruments, each tuned to a pitch at which it will be put in vibration to produce its fundamental note by one only of the transmitting-instruments. A separate instrument is therefore employed for every pitch, each instrument being capable of transmitting or receiving but a single note, and thus as many separate instruments are required as there are messages or musical notes to be transmitted.

My invention has for its object, first, the transmission simultaneously of two or more musical notes or telegraphic signals along a

single wire in either or both directions, and with a single battery for the whole circuit without the use of as many instruments as there are musical notes or telegraphic signals to be transmitted; second, the electrical transmission by the same means of articulate speech and sounds of every kind, whether musical or not; third, the electrical transmission of musical tones, articulate speech, or sounds of every kind without the necessity of using a voltaic battery.

In my Patent No. 174,465, dated March 7, 1876, I have shown as one form of transmitting-instrument a stretched membrane, to which the armature of an electro-magnet is attached, whereby motion can be imparted to the armature by the human voice, or by means of a musical instrument, or by sounds produced in any way.

In accordance with my present invention I substitute for the membrane and armature shown in the transmitting and receiving instruments alluded to above, a plate of iron or steel capable of being thrown into vibration by sounds made in its neighborhood.

The nature of my invention and the manner in which the same is or may be carried into effect will be understood by reference to the accompanying drawings, in which—

Figure 1 is a perspective view of one form of my electric telephone. Fig. 2 is a vertical section of the same, and Fig. 3 is a plan view of the apparatus. Fig. 4 is a diagram illustrating the arrangement upon circuit.

Similar letters in the drawings represent corresponding portions of the apparatus.

A, in said drawings, represents a plate of iron or steel, which is fastened at B and C to the cover or sounding box D. E represents a speaking-tube, by which sounds may be conveyed to or from the plate A. F is a bar of soft iron. G is a coil of insulated copper wire placed around the extremity of the end H of the bar F. I is an adjusting-screw, whereby the distance of the end H from the plate A may be regulated.

The electric telephones J, K, L, and M are placed at different stations upon a line, and are arranged upon circuit with a battery, N, as shown in diagram, Fig. 4.

I have shown the apparatus in one of its

simplest forms, it being well understood that the same may be varied in arrangement, combination, general construction, and form, as well as material of which the several parts are composed.

The operation and use of this instrument are as follows:

I would premise by saying that this instrument is and may be used both as a transmitter and as a receiver—that is to say, the sender of the message will use an instrument in every particular identical in construction and operation with that employed by the receiver, so that the same instrument can be used alternately as a receiver and a transmitter.

In order to transmit a telegraphic message by means of these instruments, it is only necessary for the operator at a telephone, (say J,) to make a musical sound, in any way, in the neighborhood of the plate A—for convenience of operation through the speaking-tube E—and to let the duration of the sound signify the dot or dash of the Morse alphabet, and for the operator, who receives his message, say at M, to listen to his telephone, preferably through the speaking-tube E. When two or more musical signals are being transmitted over the same circuit all the telephones reproduce the signals for all the messages; but as the signals for each message differ in pitch from those for the other messages it is easy for an operator to fix his attention upon one message and ignore the others.

When a large number of dispatches are being simultaneously transmitted it will be advisable for the operator to listen to his telephone through a resonator, which will re-entforce to his ear the signals which he desires to observe. In this way he is enabled to direct his attention to the signals for any given message without being distracted or disturbed by the signals for any other messages that may be passing over the line at the time.

The musical signals, if preferred, can be automatically received by means of a resonator, one end of which is closed by a membrane, which vibrates only when the note with which the resonator is in unison is emitted by the receiving-telephone. The vibrations of the membrane may be made to operate a circuit-breaker, which will actuate a Morse sounder or a telegraphic recording or registering apparatus.

One form of vibratory circuit-breaker which may be used for this purpose I have described in Letters Patent No. 178,399, June 6, 1876. Hence by this plan the simultaneous transmission of a number of telegraphic messages over a single circuit in the same or in both directions, with a single main battery for the whole circuit and a single telephone at each station, is rendered practicable. This is of great advantage in this, that, for the conveyance of several messages, or signals, or sounds over a single wire simultaneously, it is no longer necessary to have separate instruments correspondingly tuned for each given sound, which plan requires nice adjustment of the

corresponding instruments, while the present improvement admits of a single instrument at each station; or, if for convenience several are employed, they all are alike in construction, and need not be adjusted or tuned to particular pitches.

Whatever sound is made in the neighborhood of any telephone, say at J, Fig. 4, is echoed in fac-simile by the telephones of all the other stations upon the circuit; hence, this plan is also adapted for the use of the transmitting intelligibly the exact sounds of articulate speech. To convey an articulate message it is only necessary for an operator to speak in the neighborhood of his telephone, preferably through the tube E, and for another operator at a distant station upon the same circuit to listen to the telephone at that station. If two persons speak simultaneously in the neighborhood of the same or different telephones, the utterances of the two speakers are reproduced simultaneously by all the other telephones on the same circuit; hence, by this plan a number of vocal messages may be transmitted simultaneously on the same circuit in either or both directions. All the effects noted above may be produced by the same instruments without a battery by rendering the central bar F H permanently magnetic. Another form of telephone for use without a battery is shown in Fig. 5, in which O is a compound permanent magnet, to the poles of which are affixed poll-pieces of soft iron P Q surrounded by helices of insulated wire R S.

Fig. 6 illustrates the arrangement upon circuits of similar instruments to that shown in Fig. 5.

In lieu of the plate A in above figures, iron or steel reeds of definite pitch may be placed in front of the electro-magnet O, and in connection with a series of such instruments of different pitches, an arrangement upon circuit may be employed similar to that shown in my Patent No. 174,465, and illustrated in Fig. 6 of Sheet 2 in said patent. The battery, of course, may be omitted.

This invention is not limited to the use of iron or steel, but includes within its scope any material capable of inductive action.

The essential feature of the invention consists in the armature of the receiving-instrument being vibrated by the varying attraction of the electro-magnet, so as to vibrate the air in the vicinity thereof in the same manner as the air is vibrated at the other end by the production of the sound. It is therefore by no means necessary or essential that the transmitting-instrument should be of the same construction as the receiving-instrument. Any instrument receiving and transmitting the impression of agitated air may be used as the transmitter, although for convenience, and for reciprocal communication, I prefer to use like instruments at either end of an electrical wire. I have heretofore described and exhibited such other means of transmitting sound, as will be seen by reference to the pro-

ceedings of the American Academy of Arts and Sciences, Volume XII.

For convenience, I prefer to apply to each instrument a call-bell. This may be arranged so as to ring, first, when the main circuit is opened; second, when the bar F comes into contact with the plate A. The first is done to call attention; the second indicates when it is necessary to readjust the magnet, for it is important that the distance of the magnet from the plate should be as little as possible, without, however, being in contact. I have also found that the electrical undulations produced upon the main line by the vibration of the plate A are intensified by placing the coil G at the end of the bar F nearest the plate A, and not extend it beyond the middle, or thereabout.

Having thus described my invention, what I claim, and desire to secure by Letters Patent, is—

1. The union upon, and by means of, an electric circuit of two or more instruments, constructed for operation substantially as herein shown and described, so that, if motion of any kind or form be produced in any way in the armature of any one of the said instruments, the armatures of all the other instruments upon the same circuit will be moved in like manner and form; and if such motion be produced in the former by sound, like sound will be produced by the motion of the latter.

2. In a system of electric telegraphy or telephony, consisting of transmitting and receiving instruments united upon an electric circuit, the production, in the armature of each receiving-instrument, of any given motion, by subjecting said armature to an attraction varying in intensity, however such variation may be produced in the magnet, and hence I claim the production of any given sound or sounds from the armature of the receiving-instrument,

by subjecting said armature to an attraction varying in intensity, in such manner as to throw the armature into that form of vibration that characterizes the given sound or sounds.

3. The combination, with an electro-magnet, of a plate of iron, or steel, or other material capable of inductive action, which can be thrown into vibration by the movement of surrounding air, or by the attraction of a magnet.

4. In combination with a plate and electro-magnet, as before claimed, the means herein described, or their mechanical equivalents, of adjusting the relative position of the two, so that, without touching, they may be set as closely together as possible.

5. The formation, in an electric telephone, such as herein shown and described, of a magnet with a coil upon the end or ends of the magnet nearest the plate.

6. The combination, with an electric telephone, such as described, of a sounding-box, substantially as herein shown and set forth.

7. In combination with an electric telephone, as herein described, the employment of a speaking or hearing tube, for conveying sounds to or from the telephone, substantially as set forth.

8. In a system of electric telephony, the combination of a permanent magnet with a plate of iron or steel, or other material capable of inductive action, with coils upon the end or ends of said magnet nearest the plate, substantially as set forth.

In testimony whereof I have hereunto signed my name this 13th day of January, A. D. 1877.

A. GRAHAM BELL.

Witnesses:

HENRY R. ELLIOTT,
EWELL A. DICK.

2550
1877