

I. L. G. RICE.
EMBROIDERING-MACHINE.

No. 186,953.

Patented Feb. 6, 1877.

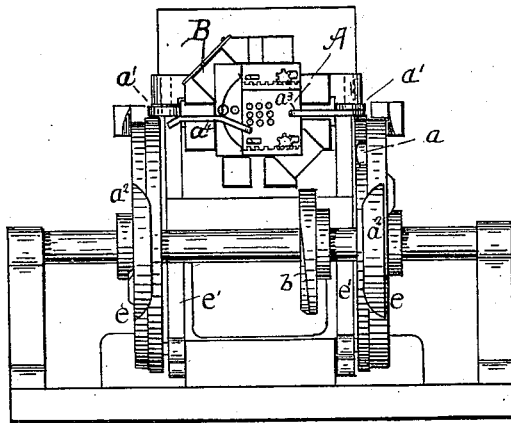

Fig. 7.

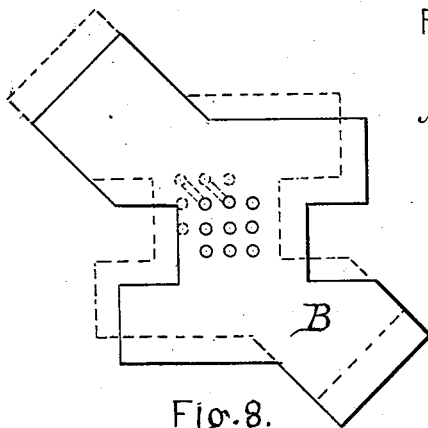

Fig. 8.

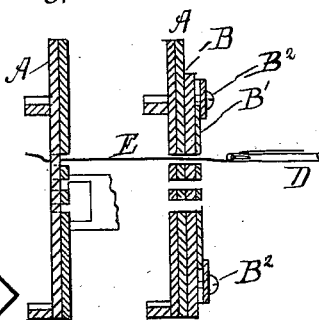

Fig. 9.

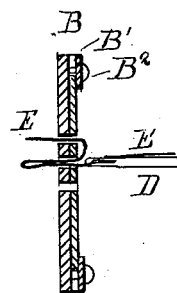

Fig. 10.

Fig. 11.

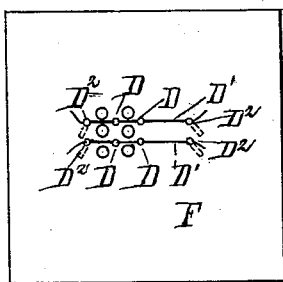

Fig. 12.

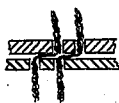

Fig. 13.

Fig. 14.

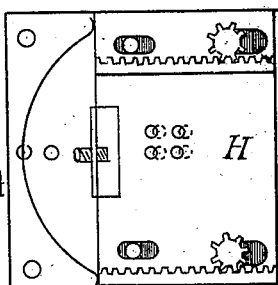
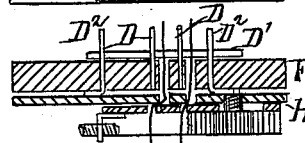

Fig. 15.



WITNESSES

Charles C. Livermore
Charles H. Bacon

INVENTOR

Israel L. Rice

UNITED STATES PATENT OFFICE.

ISRAEL L. G. RICE, OF CAMBRIDGE, MASSACHUSETTS.

IMPROVEMENT IN EMBROIDERING-MACHINES.

Specification forming part of Letters Patent No. **186,953**, dated February 6, 1877; application filed November 13, 1875.

To all whom it may concern:

Be it known that I, ISRAEL L. G. RICE, of the city of Cambridge, and State of Massachusetts, have invented a new and useful Machine for Embroidering with Zephyr-Yarn, or making "worsted-work," as it is called, which invention is fully set forth in the following specification, reference being had to the accompanying drawings.

The object of my invention is to rapidly make worsted work by means of the mechanism herein described, instead of doing it by hand. This is accomplished, principally, through the following agencies: A creel on which bobbins that have wound upon them yarns to correspond in color with the colors shown on the pattern are placed, there being a different bobbin to each stitch that there is to be shown in the design; a series of needles threaded with the yarns are placed in a guide-plate to direct them, their order of arrangement being the same as that of the stitches in the pattern, there being a different needle for each bobbin; a needle-plate to hold the needles, grippers to take hold of the yarn, so as to seize it at certain points, and a card-plate to hold the card or canvas on which the design is to be worked.

Figure 1 is a plan view of the embroidery-machine of my invention. Fig. 2 is a sectional view of the same. Fig. 3 shows the appearance of the face of the worsted work or embroidery after it is completed. Fig. 4 is a section through the same, the face being turned downward. Fig. 5 is a sectional view through the essential parts of the machine—the front grippers A, the card-plate B, the needle-guide-plate C, the needles D D and yarn E, the needle-plate F and rear grippers H. Fig. 6 is a view of a needle, D, showing the V-shaped eye. The object of this is to allow the yarn to freely move out of the eye of the needle toward the point, but prevent the yarn from slipping out of the needle at the opposite end of the eye, so that it will not be unthreaded. Fig. 7 is a front view of the machine. Fig. 8 is an enlarged view of the card-plate B. Fig. 9 is a sectional view of the front grippers A, card-plate B, card B¹, clamps to hold the card B² B², needle D, and yarn E. Fig. 10 shows the front grippers A as they have moved back

and drawn the yarn through the card plate, so as to form a stitch. Fig. 11 is a sectional view of the card-plate, card, needle, and yarn, and the stitch, together with the loop on the opposite side of the card-plate. This loop is caused by the needle carrying the yarn some distance beyond the outer edge of the hole in the card-plate, through which it is passed. Then, as the needle returns and withdraws from the hole, the fibers of the yarn cause a slight resistance to the yarn passing through the hole; so it bends, and the loop is formed. Two loops would be formed at the end near the point of the needles, were it not that the long end of the yarn is firmly held by grippers, and is, consequently, pulled through. The loops that are on the outer edges of these holes are cut off before the needles withdraw. After these loops are cut the needles withdraw, and the stitches are left all made and complete, as in the pattern. Fig. 12 is a view of the needle-plate F. The needles D D are held in place by means of a strip of thin steel, D¹, that passes through the slotted holes in the ends of the needles. These plates D¹ D¹ are held in place by means of the slotted pins D² D² that are firmly secured to the needle-plate F. This is more fully shown in Fig. 13, which is a sectional view of the needle-plate F and rear grippers H. Fig. 14 is a view of the grippers, the front and rear grippers being identical in form. Fig. 15 is a sectional view of the grippers, illustrating their principle of action. When the yarn is in the holes in the grippers it passes through two plates that form the grippers. Now, if one of these plates is moved beside the other a short distance (as shown by dotted lines in Fig. 14) the yarns are brought between the two plates, as seen in Fig. 15. These plates are then screwed together by means of the screws in the plate, on which is a gear that is worked by the rack that is fastened to the rear sliding plate of the grippers.

The bobbins having been arranged on the creel according to the pattern that is to be worked, and the needles having been threaded by means of a thin hook made to enter the eye and draw the yarn through, and arranged in the guide-plate C, and then secured to the needle-plate F, (the yarn passing through the rear grippers H, as shown,) the card or canvas

is then clamped onto the card-plate B, and the front grippers A are placed in the frame up close to the card-plate, the needle-guide plate being up close against the guard-plate. The holes through all the plates are made so as to be opposite one another.

The operation of the machine is as follows, all the movements being caused by a single revolution of the main shaft: The needles, being in the position shown in Fig. 1, move forward through the card, card-plate, and front grippers, so that the points project about an inch beyond that part of the grippers nearest them. (See Fig. 2.) This is done by the cams *e e* acting upon the bell-crank levers *e' e'*. Second, the needles withdraw, leaving about one-eighth of an inch of yarn projecting beyond the surface of the front grippers. (See Fig. 5.) This is done by cams *e e* and levers *e' e'*. Third, front grippers A gripe yarn, Fig. 5. (For the explanation of griping see Figs. 13, 14, and 15.) This movement is produced by the projection *a*, Fig. 7, pushing the rod *a³*, that is fastened to the front plate of these grippers. This bends the yarn over, as seen in Fig. 15, and the same movement causes the rack that is fast upon the gripper-plate (see Fig. 14) to revolve the gear-headed screws, and thus the two plates that form the grippers are pressed tightly together, and each piece of yarn griped. Fourth, rear grippers release yarn. This is done by the projection *h* striking the lever *h¹*, (see Fig. 5,) and this lever pushes the rod *h⁵*, that is opposite on the outer gripper-plate. The operation of griping is the same as described in the previous movement. Fifth, front gripper-plate A moves forward about an inch and a half, (see Figs. 9 and 10,) drawing the yarn through the eyes of the needles, and the holes in the several plates. This is done so as to obtain yarn to make the stitch. The movement is made by means of the projections *a² a²* on the cams *e* coming in contact with and causing the rollers *a¹ a¹* to revolve by friction. (See Figs. 1 and 7.) Sixth, front gripper-plate lets go of yarn. This is done by means of projections on the cam *e* pushing the pin *a⁴*. Seventh, rear gripper-plate H seizes yarn. (See Fig. 13.) This is done by means of the projection *h²* on the cam

e moving the lever *h³*, and this pushes the rod *h⁴*, so as to operate the grippers. While this motion is taking place the operator of the machine removes the front grippers from the machine. Eighth, needle-plate moves back a little. Ninth, card-plate moves up, as seen in Fig. 8, the dotted lines representing the movement; and the dotted lines from one hole to another represent the position of the stitch after it is made. The movement is made by means of the cam *b*. (See Fig. 7.) Tenth, needle-plate goes forward, the points of the needles projecting about an inch and a quarter beyond the card-plate, and thus make the stitch, Fig. 11. Eleventh, needle-plate moves back part way, and, in doing so, forms loops on the back of card-plate. (See Fig. 11.) These loops are then cut off by hand. Twelfth, needle-plate then moves back into the position shown in Fig. 1. The card-plate is then removed, and the card or canvas taken off. Dissolved rubber or some other suitable elastic cement is applied to the cut ends that are in the card, and a piece of cloth pressed onto these ends. When dry, the embroidery is ready for use. Another piece of card is then secured to the card-plate by means of clamps, and it is placed in the machine to be worked as before.

It will be seen that a large number of copies of the designs may be worked off rapidly and cheaply by means of this machine; for by this machine many thousand stitches may be made at the same time, while by hand but a single stitch can be made at a time.

I claim as my invention—

The combination of the needles D D, arranged in their holding-plate F, substantially as described, whereby each needle forms but a single stitch of the pattern, with the guiding-plate C and clamping-plates A and H, and their operative mechanism, whereby a complete pattern is formed when each needle has taken but a single stitch, substantially as shown and described.

ISRAEL L. G. RICE.

Witnesses:

CHARLES C. LIVERMORE,
CHARLES H. BACON.