

C. G. SCHULZE.
HEAT-REGULATOR.

No. 186,959

Patented Feb. 6, 1877.

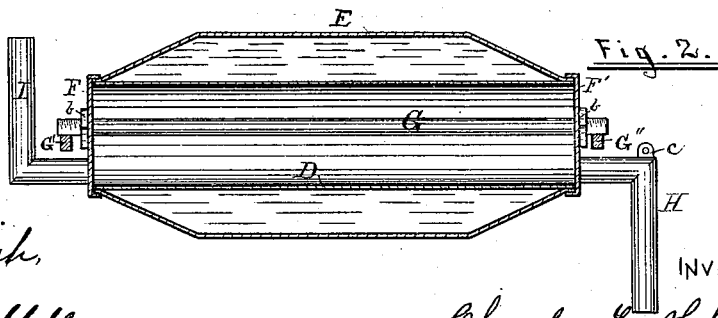
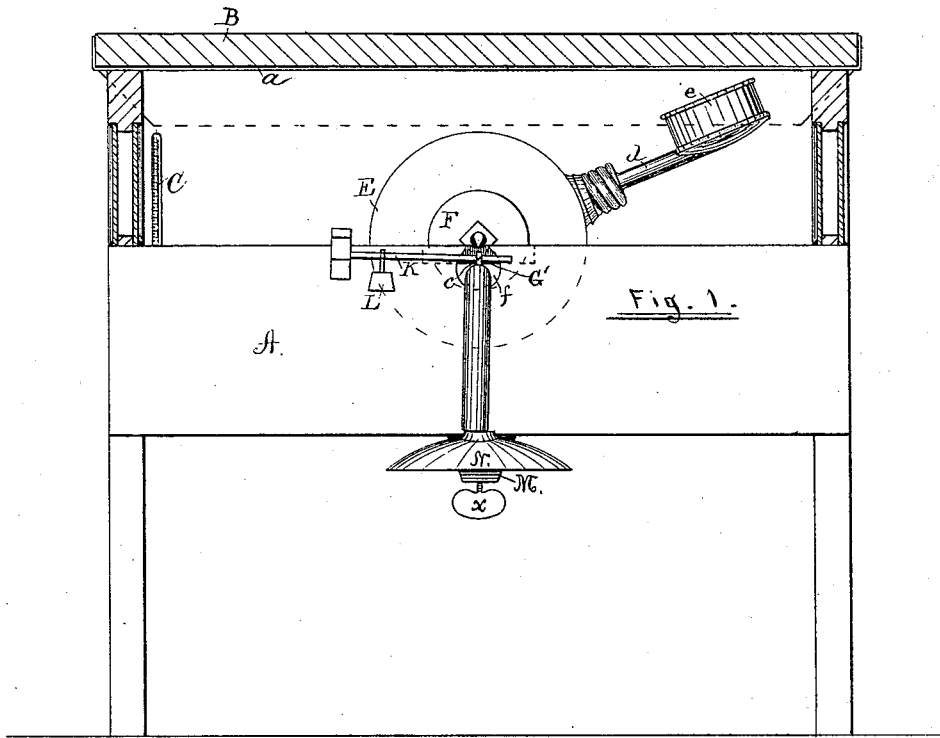

WITNESSES.

J. J. Roach
J. C. Hubbell

INVENTOR.

Charles G. Schulze

BY *H. N. Jenkins*
ATTORNEY.

UNITED STATES PATENT OFFICE

CHARLES G. SCHULZE, OF NEW ORLEANS, LOUISIANA.

IMPROVEMENT IN HEAT-REGULATORS.

Specification forming part of Letters Patent No. **186,959**, dated February 6, 1877; application filed July 13, 1876.

To all whom it may concern:

Be it known that I, CHARLES G. SCHULZE, a resident of the city of New Orleans and State of Louisiana, have invented a certain new and useful Improvement in Heat-Regulators; and I do hereby declare the following to be a full, clear, and correct description of the same, reference being had to the annexed drawing, making a part of this specification.

My invention relates to a means for heating and automatically regulating to a fraction of a degree the liquid contained between two cylinders, thereby forming a heat accumulator and radiator, through the instrumentality of which the air contained within apartments provided with my apparatus may be kept at a degree of temperature suitable for the purpose to which the apparatus is to be applied.

In the annexed drawing, Figure 1 represents my invention as applied to a covered box, a portion of the said box being removed, in order to show more clearly the nature of my invention. Fig. 2 is a longitudinal section of the movable or working portion of my apparatus.

The drawing, as before stated, represents my invention as applied to a box, A, the top of which is provided with a cover, B, having an interior lining of cloth or other yielding material, a, for the purpose of giving to the cover an air-tight fit. In the sides or ends of the box are openings, provided with two thicknesses of plate-glass, through which a view of a thermometer, C, as well as the interior of the box, may be obtained.

My invention consists of a cylindrical zinc tube, D, provided with an outer metal casing or jacket, E, of a somewhat greater diameter, and whose ends are conically formed, so that their smallest diameters may be but slightly larger than the ends of the central tube D, to which they must be soldered or otherwise secured. To these ends are fitted the heads or caps F F', which are drawn tightly over the same by a central bolt or stud, G, the ends of which protrude through the said heads, and are provided with screws and nuts, as shown at b b'. Those portions of the ends of the stud which project beyond or outside of

the nuts are so cut as to give to the lower side of the same knife or balance edges similar to those with which weighing-scales are provided.

The holes for the passage of the stud through the heads F F' should be drilled a little above the center of the same, so that the knife-edges of the stud may, when the apparatus is put together, be on or a little above the central line of the cylinder. G' G'' are metal bearings, which are let into the sides of the box, and upon which the balance-edges above mentioned are designed to rest. The heads F F' are each provided near their lower edges with a pipe; that turned downward, and marked H, for the introduction of the heat, and that turned upward, and marked I, for the discharge of the same. The upper side of the elbow of pipe H is provided with a lug, e, in which is fitted a rod or beam, k, provided with an adjustable weight, as shown at L. About the center of the outer cylinder E, and on the side opposite to that on which the weight operates, is tightly screwed or otherwise fitted a hollow stem, d, the projecting end of which is provided with a covered bowl, e, into which, as the temperature is raised, a certain proportion of the liquid contained in the outer cylinder is forced, and from whence it is again returned to the aforesaid cylinder on the lowering of the temperature therein. Below the bearing-plates G' G'' the sides of the box are provided with openings f, which are made sufficiently large for the passage and necessary vibrating motion of the pipes H and I. These openings afford a means for the admission of fresh air to the interior of the box, and as the temperature of the said air in its inward passage is necessarily raised by coming in contact with the heated pipes it does not cause any perceptible change of temperature within the box. To the bottom of the box, and on a line immediately below the cylinders, is bolted or otherwise secured one end of a spring-bar, M, to the opposite or free end of which is secured a metal or fire-clay dome, N, having an opening in its top, which is held, when the apparatus is not in use, immediately below the opening of the pipe H. This dome is capable of being raised or lowered by means

of a screw, *x*, so that the space between it and the pipe H may be varied in accordance with the intensity of the heat furnished.

The heat necessary for the operation of this invention may be furnished by a lamp or gas-jet, which should be placed directly under the dome, so that the heat may pass up through the opening of the same into the pipe H, and from thence into the cylinder D, thereby heating the water surrounding the same, and causing the heat to be radiated from the outer jacket to all sections of the apartment.

In using this invention for purposes of incubation it may be necessary to provide the apartment, in which it is used with a certain quantity of water in order to keep the atmosphere moist.

The inner cylinder D should be constructed of a material more susceptible of expansion from heat than that of the outer cylinder, in order to prevent as much as possible the enlargement of the space between the cylinders.

Having described my invention, what I claim as new, and desire to secure by Letters Patent, is—

1. The combination of the zinc cylinder D, jacket E, and heads F F', the latter secured to the former by means of a bolt or stud, G, having its outer ends cut substantially as described, so as to form edges upon which the whole may be balanced, as set forth.

2. In combination with the cylinder D, jacket E, heads F F', and stud G, the hollow stem *d*, and bowl *e*, as described, and for the purpose set forth.

3. In combination with the cylinder D provided with jacket E, hollow stem *d*, and bowl *e*, the heads F F', provided with pipes H I, beam K, and weight L, as specified, and for the purpose set forth.

4. In a heat-regulating apparatus the lever M, provided at its free end with dome N and set-screw *x*, arranged to operate in the manner shown, and for the purpose specified.

CHAS. G. SCHULZE.

Witnesses:

J. C. HUBBELL,
T. J. ROACH.