

J. S. WILSON.
PUMPING ENGINE.

No. 186,967

Patented Feb. 6, 1877.

Fig. 1

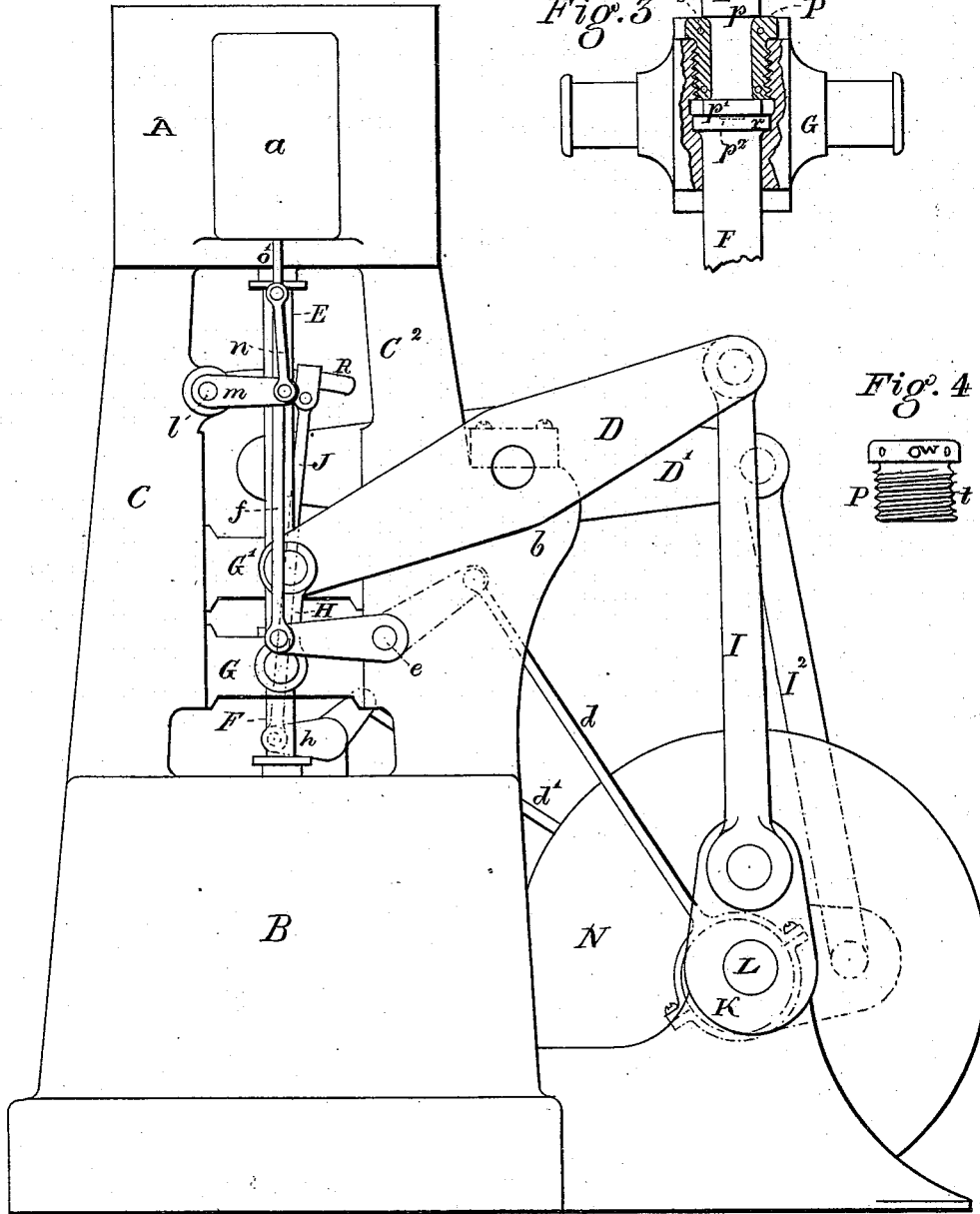

Witnesses

John A. Grant
D. Louis Shivers

Inventor.

Joseph S. Wilson
per Edw. Brown
attorney

J. S. WILSON.
PUMPING ENGINE.

No. 186,967

Patented Feb. 6, 1877.

Fig. 2

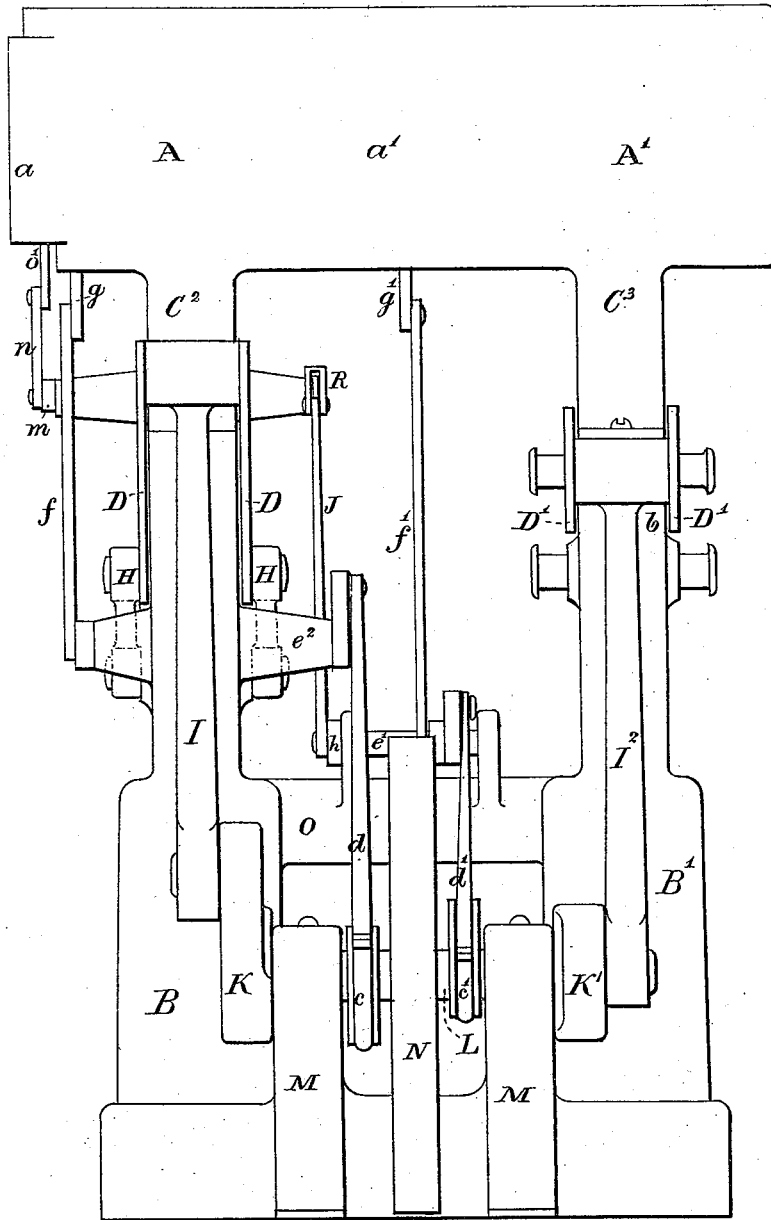

Witnesses
John A. Grant
D. Louis Shivers

Inventor.
Joseph S. Wilson
per Edw. Brown
attorney

UNITED STATES PATENT OFFICE.

JOSEPH S. WILSON, OF PHILADELPHIA, PENNSYLVANIA, ASSIGNOR OF ONE-HALF OF HIS RIGHT TO WILLIAM CRAMP & SONS SHIP AND ENGINE BUILDING COMPANY.

IMPROVEMENT IN PUMPING-ENGINES.

Specification forming part of Letters Patent No. **186,967**, dated February 6, 1877; application filed September 12, 1876.

To all whom it may concern:

Be it known that I, JOSEPH SHIELDS WILSON, of 703 East York street, Philadelphia, Pennsylvania, have invented a new and useful Improvement in Pumping-Engines, which improvement is fully set forth in the following specification, reference being had to the accompanying drawings.

My improvement relates to direct-acting vertical pumping-engines, and consists in, first, the combination and arrangement of parts for the direct application of steam-power to pumping, when the steam-cylinders and pumps are vertical, or nearly so, and the connection to the fly-wheel shaft is made by a beam supported on the engine-frame; second, obtaining the motion for the supplementary cut-off valve (commonly called the "expansion-valve") of the high-pressure cylinder from the eccentric of the low-pressure engine, with the engines coupled at, or approximating to, right angles, when double engines are used of the independent compound type; third, method of connecting piston and pump rods to each other and to cross-head.

Figure 1 is a side elevation of the engine. Fig. 2 is an end elevation. Figs. 3 and 4 show the mode of connecting the piston-rod and pump-rod.

A is the high-pressure steam-cylinder, and A' the low-pressure, with an intermediate receiver, *a'*, between it and the cylinder A. B B' are the pumps. The cylinders A A' and pumps B B' are connected together by the frames C C¹ on the one side, and C² C³ on the other, which form the main cross-head guide. The frames C² C³ have each a pedestal, *b b*, for supporting the double beams D D', each of which is made double, so as to fork or span the portion of the frame C² C³ which connects the steam-cylinders to the pumps, as shown in Fig. 2. E E are the piston-rods; F F, the pump-rods, and G G' the main cross-heads, the latter being connected to the low-pressure piston-rod. H H are links, connecting the cross-head G and beam D. I I² are rods, connecting the beams D D' with the cranks K K', placed at, or approximating to, right angles on the shaft L. M M are pedestals, for sup-

porting the shaft L, and are secured to the pumps B B'. N is the fly-wheel, secured to the shaft L. *a* is the high-pressure cylinder valve-chest. *c* is the high-pressure eccentric, and *c'* the low-pressure. *d* is the high-pressure eccentric-rod, which operates the rock-shaft *e*, working in bearings *e*² on the frame C². *f* is the valve-rod, connecting the rock-shaft *e* with the main high-pressure valve-stem *g*. *d'* is the low-pressure eccentric-rod, which operates the rock-shaft *e'*, working in bearings on the tie O, between the pumps B B'. *f'* is a valve-rod, connecting the rock-shaft *e'* with the low-pressure valve-stem *g'*. *h* is an arm, on the end of the rock-shaft *e'*, next to the high-pressure cylinder, for operating the expansion-valve of the high-pressure cylinder. J is a rod, connecting the arm *h* with the quadrant R, so arranged that it can be shifted on the latter, to alter the point of cutting off. The quadrant R is secured to one end of the shaft *l*, working in bearings on the frame C. On the other end is secured the arm *m*. *n* is a rod, connecting the arm *m* with the expansion valve-stem *o'*.

The piston and pump rods are united to each other and to the cross-head in the following manner. (See Figs. 3 and 4:) The piston-rod E is reduced in diameter near the lower end, so as to form a shoulder, *p*, and a collar, *p*¹. *p*² is a projection, fitting into a corresponding recess on the pump-rod F, so as to keep the two rods in the same center-line. *r* is a collar on the upper end of the pump-rod F. P is a round nut or bushing, in two pieces, made to fit the piston-rod E between the shoulder *p* and collar *p*¹. A thread, *t*, is cut on the outside of the nut, to within a short distance of the top of the nut, which thread is larger in diameter than the collar *r* on the pump-rod F. W are spanner-holes, for screwing the nut around. Pins *s* are secured to one-half of P, fitting into corresponding recesses in the other half, before the thread is cut on the outside, in order to match the two halves. The lower half of the cross-head G is bored out to receive the rod F and its collar *r*. The upper half has a thread cut in it, to suit the thread of the nut P. The base contains the pump B,

with its valve-chambers on each side. In the working engine, the condenser is placed between the pump and the crank-shaft, and worked by a rod from the beam. It is, however, unnecessary to describe or show the construction of these, as they are well known.

It will be seen that, by this construction, I am able to use the modern compound engine to great advantage in large pumping-engines, and in its most advantageous—that is, vertical—position, and with great economy in weight and compactness of form.

One feature of my invention here shown—that is, the connecting and equalizing the motion of the two piston-rods through the beams and crank-shaft—could, of course, be used with two high-pressure cylinders of the ordinary type, but not with such economy as in the combination herein described.

The engine here shown, though constructed especially for pumping water for the water-works of towns, is equally applicable to pumping air and other fluids.

I claim—

1. The combination, in a vertical direct-acting pumping-engine, of the steam-cylinder A, pump B, connecting-links H, walking-beam D, connecting-rod I¹, and fly-wheel shaft L, substantially as herein described.

2. The combination, in a vertical direct-acting pumping-engine, of the walking-beam D, supported upon the frame C², which connects the steam-cylinder to the pump, the connecting-rod I¹, and the crank-shaft L, as herein described.

3. In a direct-acting vertical pumping-engine, of the independent compound type, the combination of the steam-cylinders A A', operating the pumps B B', and coupled together at right angles by means of the links H, beams D D', connecting-rods I¹ I², and crank-shaft L, as herein described.

4. The combination, in a direct-acting pumping-engine, of the double beam D, spanning the frame C², which connects the cylinder to the pump, for the purpose of communicating the motion of the piston to the fly-wheel, as herein described.

5. The combination of the piston-rod E, pump-rod F, cross-head G, nut P, and collars p' and r, substantially as shown.

J. SHIELDS WILSON.

Witnesses:

EDWARD BROWN,
JOHN F. GRANT.