

D. ARNDT.

SAFETY-GATES FOR DRAW-BRIDGES.

No. 186,971

Patented Feb. 6, 1877.

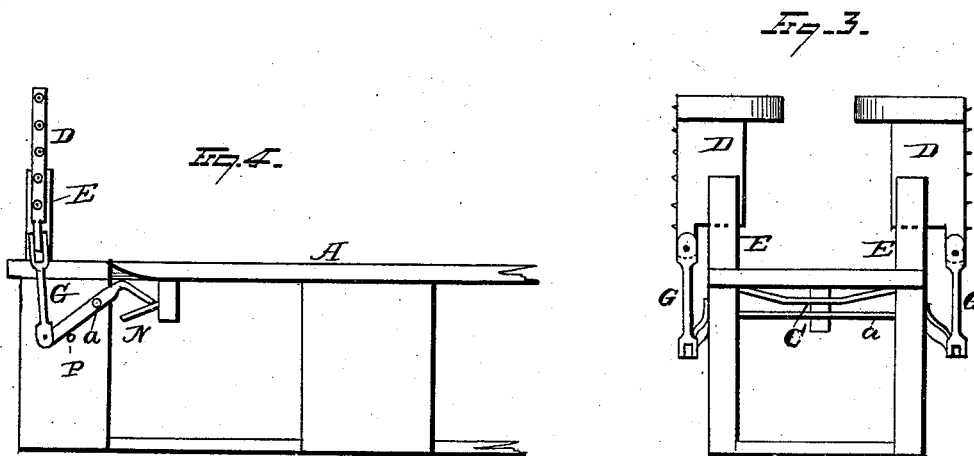
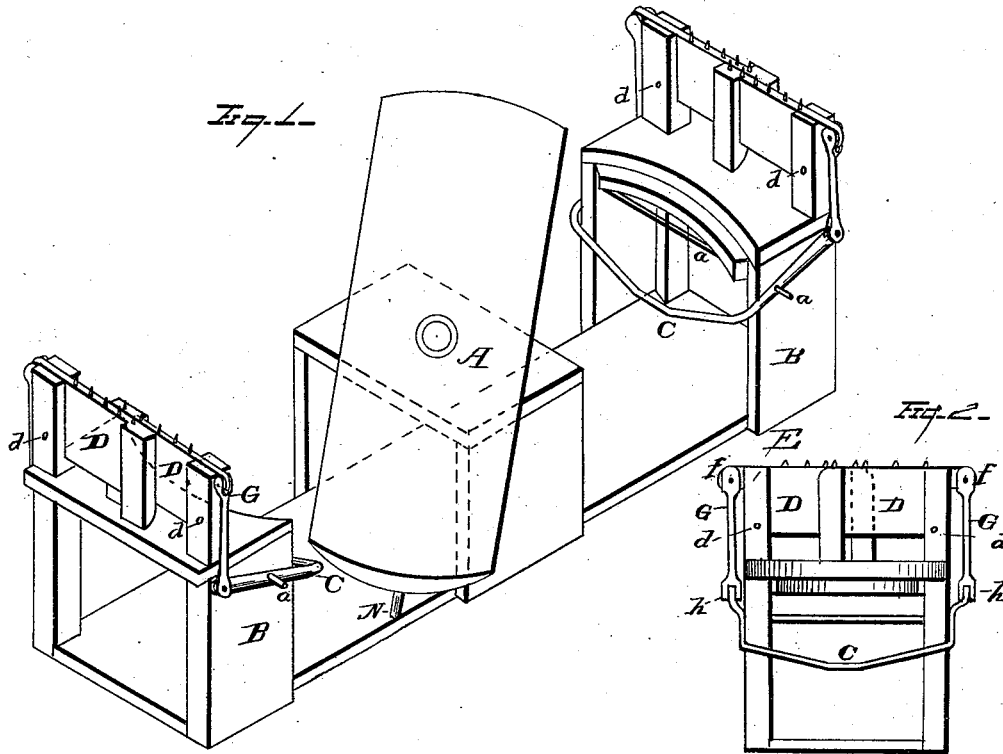

WITNESSES
Ed. J. Nottingham
A. Bright

INVENTOR
Daniel Arndt
By Seagett and Seagett
ATTORNEYS

UNITED STATES PATENT OFFICE.

DANIEL ARNDT, OF CLEVELAND, OHIO.

IMPROVEMENT IN SAFETY-GATES FOR DRAW-BRIDGES.

Specification forming part of Letters Patent No. **186,971**, dated February 6, 1877; application filed December 30, 1876.

To all whom it may concern:

Be it known that I, DANIEL ARNDT, of Cleveland, in the county of Cuyahoga and State of Ohio, have invented certain new and useful Improvements in Safety-Gates for Draw-Bridges; and I do hereby declare the following to be a full, clear, and exact description of the invention, such as will enable others skilled in the art to which it pertains to make and use it, reference being had to the accompanying drawing, which forms part of this specification.

My invention relates to safety-gates for draw-bridges.

In the drawing, Figure 1 represents an isometric view of a draw-bridge and gate embodying my invention. Fig. 2 is an end view, as seen from the bridge when the gates are closed. Fig. 3 is a similar view when the gates are open. Fig. 4 is a view in side elevation with gates open, showing cam projection on under side of bridge.

My invention consists in the parts and combinations as hereinafter specified and claimed, wherein A represents a draw-bridge pivoted centrally, and B B the bridge piers or abutments. They may be of any kind or construction, as my device is applicable to all kinds. C is a peculiarly-shaped cam-bar, pivoted on both sides of the bridge-pier at *a*. It may be constructed of one piece or of three pieces—two side pieces and a front piece, firmly secured to each other. These cam-bars are bent, as shown in the drawing, so as to secure a gradual opening and closing of the bridge-gates, and so as to close them before the bridge is entirely open. The pivot at *a* may be a bar or rod passing entirely through the pier, as shown in the drawing, thus serving for both ends of the cam-rod C, or said ends may be pivoted in any other suitable manner. D are the gates, which may be of any shape, construction, or material. They are pivoted at *d* to the bridge-posts, and are provided with the projecting pieces *f*. G is a connecting bar or link, which is attached at its upper end to the gate projection *f*, and at its lower end to cam-bar C, as shown at *h*. N is a cam projection, fixed at the under side of the bridge at each end of the same, which acts on the cam-rod C, to open and close the

gates. This cam projection may be of any form or shape, and may be provided, and preferably so, with anti-friction rollers, so as to facilitate the action of the parts.

The operation of the device is as follows: When the gate is closed, as shown in Fig. 4, the cam projection N is in a position under the central part of the cam-bar C. In this position the connecting-link G is in its lowest position, and the gate is consequently open. If, now, the bridge is turned on its pivot to open, the cam projection N moves to one side, and gradually allows the cam-bar C to drop, which it does by reason of the weighted gates, and which are gradually closed as the cam-bar is lowered. The gates begin to close as the bridge opens, and are entirely closed before the bridge is entirely open. If, now, the bridge is closed, the cam projection N strikes the under side of the cam-bar when the bridge is nearly half closed, and gradually elevates the same, which causes the outer ends of said cam-bars to be lowered, whereby, by means of the connecting-links G, the gates are opened.

I do not limit myself in any manner to the connection between the cam-bar and the gate, as any suitable connection between the two may be used and still be comprehended by my invention; nor do I limit the operation of my device to the opening of the gates by the rising motion of the cam-bar, as such a connection might easily be had between such bar and the gates that a reverse operation would result—to wit, the opening of the gates by the depression of the cam-bar—and this construction would not only be in some cases adaptable to bridges, but might be utilized in automatic road-gates.

At P, in Fig. 4, a stop might be placed, so that the cam-bar, when the bridge is closed, should not come in contact with the same, and in this manner all jarring of the gates would be avoided. The several parts would in this case have to be so arranged as to depress the cam-bar when the bridge was being opened.

What I claim as my invention, and desire to secure by Letters Patent, is—

1. In combination with an automatic draw-bridge gate, the pivoted cam-bar C, substantially as and for the purpose described.

2. In an automatic draw-bridge gate, the

combination of a pivoted cam-bar, connecting-link, and gate, substantially as and for the purpose described.

3. In combination with a pivoted cam-bar, connecting-link, and gate, a cam projection on the under side of the bridge, substantially as and for the purpose described.

In testimony whereof I have signed my name to this specification in the presence of two subscribing witnesses.

DANIEL ARNDT.

Witnesses:

FRANCIS TOUMEY,
WM. BEHBENS.