

P. C. DURHAM.
FALLING-FRONT CARRIAGE.

No. 186,995

Patented Feb. 6, 1877.

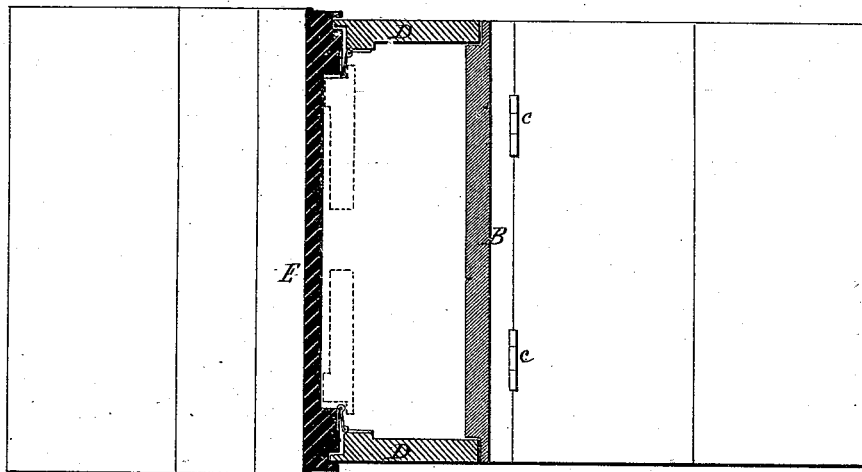
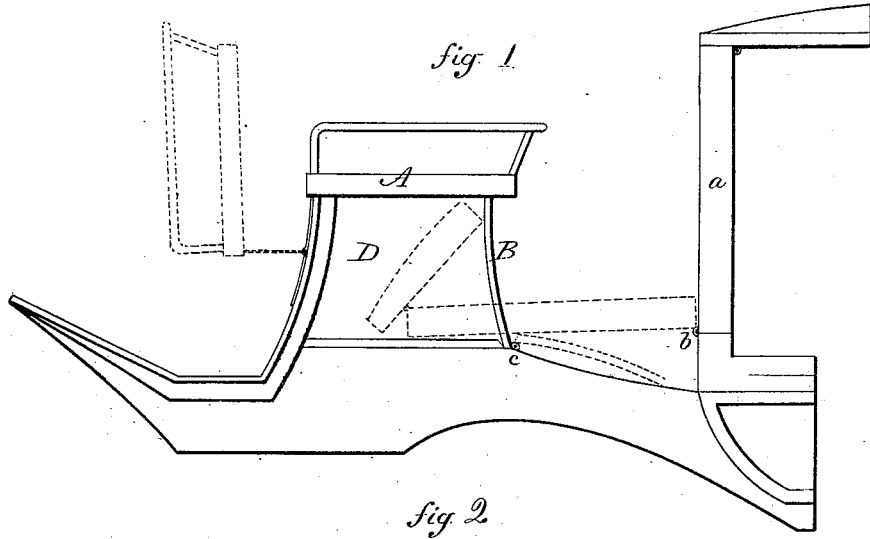

Witnesses:

J. H. Shumway,

Clara Broughton.

Peter C. Durham,
Inventor,
By Atty.

Wm. S. Earle.

UNITED STATES PATENT OFFICE.

PETER C. DURHAM, OF NEW HAVEN, CONNECTICUT, ASSIGNOR TO
DURHAM & WOOSTER, OF SAME PLACE.

IMPROVEMENT IN FALLING-FRONT CARRIAGES.

Specification forming part of Letters Patent No. 186,995, dated February 6, 1877; application filed
January 16, 1877.

To all whom it may concern:

Be it known that I, PETER C. DURHAM, of New Haven, in the county of New Haven and State of Connecticut, have invented a new Improvement in Falling-Front Carriages; and I do hereby declare the following, when taken in connection with the accompanying drawings and the letters of reference marked thereon, to be a full, clear, and exact description of the same, and which said drawings constitute part of this specification, and represent, in—

Figure 1, a side view, and in Fig. 2 a horizontal section below the seat.

This invention relates to an improvement in that class of carriages in which the front is hinged to the body, and so as to fold down forward beneath the driver's seat.

Usually the driver's seat has been arranged so as to leave a clear space beneath, into which the front might be turned—that is, the usual "boot," which forms a box shape beneath the seat, is dispensed with, and when the top is not turned down the carriage loses much of that graceful appearance which is due to inclosing the space beneath the seat to form what is termed the "boot."

The object of this invention is to construct the carriage so that this boot form may be preserved when the top is raised; and it consists in hinging the ends and rear of the boot portion, so that they may be folded or turned to open the space beneath the seat to allow the top to fall, as more fully hereinafter described.

a represents the front post of a carriage, hinged as at *b*, as in coupes. The top of other classes of carriages would be hung in the

usual manner. *A*, the seat, is hinged at the front, so as to be turned up and forward, as indicated in broken lines, and, substantially, as in the usual manner. *B* the back of the boot is hinged at the body below, as at *c*, and preferably so as to turn backward and downward, as indicated in broken lines, Fig. 1. The two ends *D* are preferably hinged to the front *E*, so as to be folded inward and against the front, as indicated in broken lines, Fig. 2; but they may be hinged upon the seat so as to turn up under the seat, or below to the body so as to turn downward.

When the top is up in place, the back *B* and ends *D* inclose the space beneath the seat, as shown; but when it is desired to throw the top forward, the seat is turned up and forward, the back *B* then turned downward, and the ends *D* folded, so as to open the space beneath the seat; then the top may be opened or turned forward, as indicated in broken lines, Fig. 1, and the seat returned to its place. When the top is again raised, the parts *B* and *D* are returned to place; thus, when the top is closed, the driver's seat is inclosed beneath, to have all the appearance of the usual close box or boot.

I claim—

The herein-described improvement in folding-front carriages, consisting in the ends and back beneath the seat hinged, so as to open the space beneath the seat, for the folding of the top, substantially as specified.

PETER C. DURHAM.

Witnesses:

JOHN E. EARLE,
CLARA BROUGHTON.