

J. S. MILTON.

MACHINE FOR JOINTING STAVES.

No. 187,037.

Patented Feb. 6, 1877.

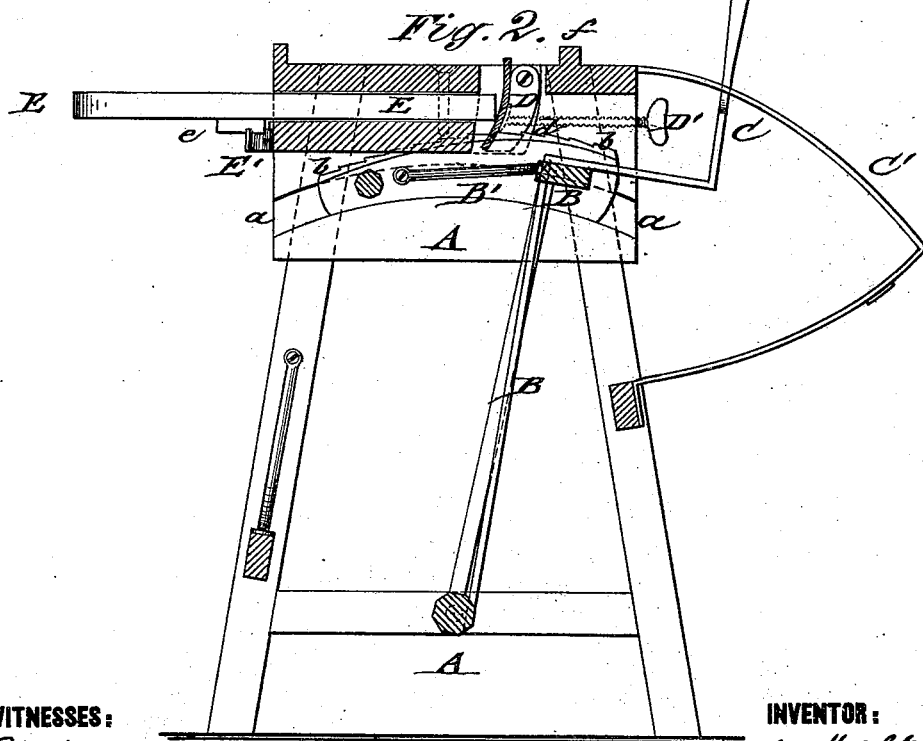
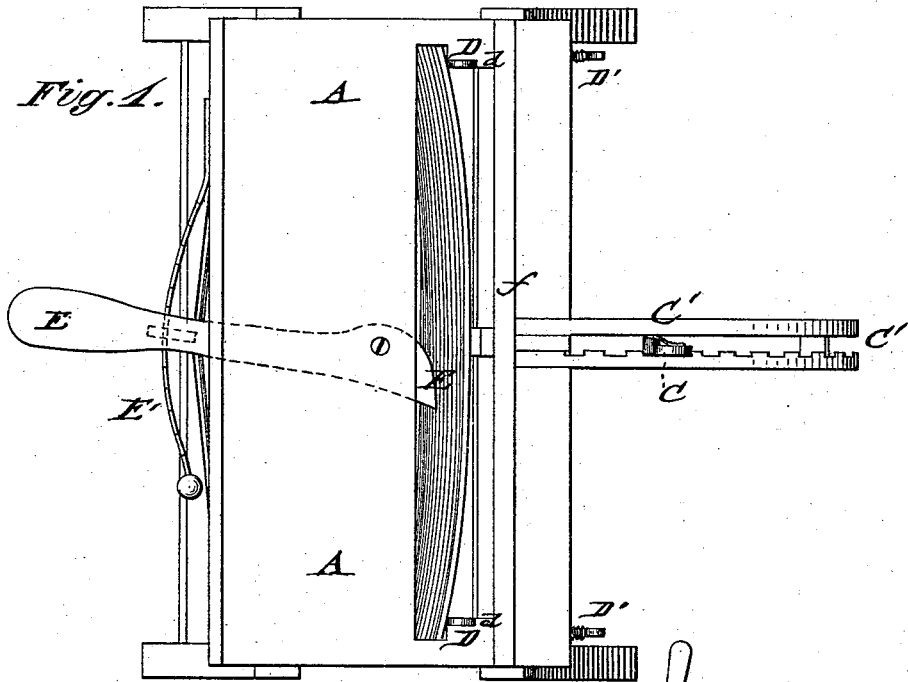

WITNESSES:

E. B. Nyquist
J. H. Scarborough

INVENTOR:

J. S. Milton
BY *Munn*
ATTORNEYS.

UNITED STATES PATENT OFFICE.

JOSEPH S. MILTON, OF BARDSTOWN, KENTUCKY.

IMPROVEMENT IN MACHINES FOR JOINTING STAVES.

Specification forming part of Letters Patent No. 187,037, dated February 6, 1877; application filed December 11, 1876.

To all whom it may concern:

Be it known that I, JOSEPH S. MILTON, of Bardstown, in the county of Nelson and State of Kentucky, have invented an Improvement in Machines for Jointing Staves, of which the following is a specification:

In the accompanying drawing, Figure 1 represents a top view, and Fig. 2 a vertical transverse section, of my improved machine for jointing staves.

Similar letters of reference indicate corresponding parts.

The invention relates to an improved machine for jointing staves in a reliable, quick, and easy manner; and it consists of a swinging stave-supporting or bed frame, with ratchet-shaped guides, operated by a hand-lever, and swinging in guide-grooves of the main frame.

The stave is pressed against curved adjustable seats and held in bulged shape by a cam-lever and spring-ratchet, for being jointed by a plane guided along the top part or table of the machine.

In the drawing, A represents the main frame of my improved stave-jointing machine, and B the swinging supporting or bed frame, that is guided in arc-shaped side grooves *a* of frame A, and secured in position by a hand-lever, C, locking into a ratchet-guide, C'. The arc-shaped bed-pieces B' of frame B are enlarged eccentrically from the front to the rear ends, and provided at the top with toothed or ratchet-shaped face-rails *b*, on which the stave is placed, the teeth being of certain height, say one-eighth of an inch, so as to admit thereby the exact grading of the staves after jointing. The top part or table of the main frame A is longitudinally recessed for placing the staves in position on the toothed face-rails of the swinging frame B, the stave resting near its ends on seats D in recesses *d* of frame A, said seats being pivoted and adjusted to a greater or less degree of inclination by set-screws D', according to the size of the barrel for which the staves are intended. For barrels of larger size, the seats D are placed at less inclination to the perpendicular than for barrels of smaller size. When the swing-

ing frame B and seats D are placed in the proper position for the stave the bulge is imparted to the same by a fulcrumed cam-lever, E, which is operated by its projecting handle, and locked by means of a lug or projecting plate, *e*, and a spring-ratchet, E'. When the stave has the required bulge for the barrel, the edge of the stave is then jointed by a carpenter's plane, which is guided along a raised longitudinal top strip, *f*, of the table. After the edge is jointed, the spring-ratchet is pressed down, so as to release the cam-lever, which is then thrown back by the spring of the stave. The stave is then turned around and the opposite edge jointed in the same manner.

The machine admits of giving any required bulge to the staves, and of cutting the edges at a uniform bevel, so as to produce perfect joints.

The toothed face-rails may be dispensed with when it is not desired to grade the staves. The correspondingly-notched ratchet-guide C' of lever may then be made smooth, or with any suitable teeth for locking the lever.

The machine can be operated with great facility by any workman without requiring skilled hands, accomplishing its work with accuracy, ease, and dispatch.

Having thus described my invention, I claim as new and desire to secure by Letters Patent—

1. In a stave-jointing machine, the combination of the swinging and guided bed-frame B, having arc-shaped eccentric bed-pieces B', and of the curved adjustable stave-seats D, with a swinging cam-lever, E, and a locking spring-ratchet, E', operated substantially in the manner and for the purpose set forth.

2. In combination with operating devices, substantially as specified, the arc-shaped and eccentrically-enlarged bed-pieces B', provided with toothed or ratchet-shaped face-rails, for the purpose of grading the staves, substantially as set forth.

JOSEPH STANLEY MILTON.

Witnesses:

LEE MCGEE,
J. P. JONES.