

J. SMITH.

ATTACHMENTS TO WIND-MILLS.

No. 187,058.

Patented Feb. 6, 1877.

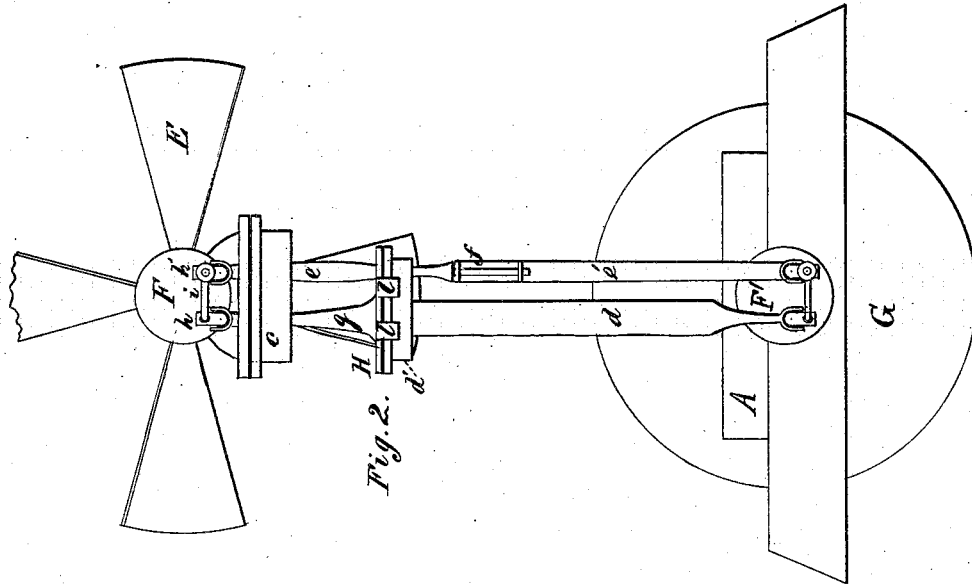

Fig. 2.

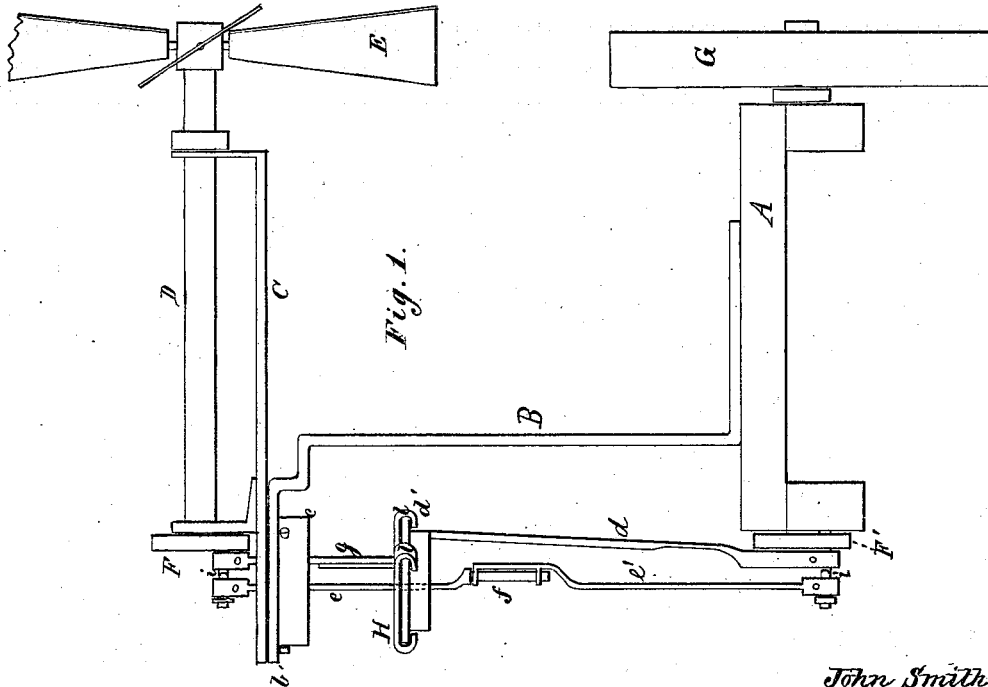

Fig. 1.

WITNESSES:

*D. P. Cowell*  
*Jno. P. Jacob*

*John Smith*

INVENTOR.

*J. M. C. Perkins*

ATTORNEY.

# UNITED STATES PATENT OFFICE.

JOHN SMITH, OF HORICON, WISCONSIN.

## IMPROVEMENT IN ATTACHMENTS TO WINDMILLS.

Specification forming part of Letters Patent No. **187,058**, dated February 6, 1877; application filed December 9, 1876.

*To all whom it may concern:*

Be it known that I, JOHN SMITH, of Horicon, in the county of Dodge and State of Wisconsin, have invented certain new and useful Improvements in Attachments to Windmills; and I do hereby declare that the following is a full, clear, and exact description thereof, that will enable others skilled in the art to which it appertains to make and use the same, reference being had to the accompanying drawings, and to the letters and figures of reference marked thereon, which form a part of this specification.

The same letters and figures of reference are used to indicate the corresponding parts.

After describing the invention, its nature and extent will be shown in the claims.

Figure 1 is a side view, and Fig. 2 is an end view, of my invention.

A is the platform, on which rests the upright B, which is provided with the turn-table *b*. C is a swinging arm, provided with two upright bearings, in which the shaft D rotates. To one end of the shaft D is attached the wind-wheel E. The arm C is provided with the flange *c*, which rotates in the turn-table *b*. One end of the shaft D is provided with the wheel F. At the point *h* in the wheel F is attached the compound crank *i*. The pitman *g* is provided with a slot at its upper end, through which one end of the compound crank *i* passes, and the other end of the crank has a bearing in the pitman *e*. The pitman *g* is firmly fastened to the horizontally-revolving disk H. The disk H is provided with the projecting arms *l l*, which are bent to clasp the crown-flange of the turn-table *d'*, to which is firmly attached the pitman *d*.

The pitman *e* has a swivel-joint at the point *f*. The wheel F' and the lower end of the pitman *e* are provided with bearings for the compound crank *i*, in the same manner as at F and the top of the pitman *e*.

In ordinary windmills the wind-wheel is so constructed that it may be inclined or turned edgewise to avoid the force of a violent wind. With my invention nothing of this kind is required. The shaft C may be turned so as to completely move the wind-wheel out of the force of the wind, and not change the relative

situation of the wind wheel to the shaft C, on which it revolves. The pitmen *e e'* and *g d* are so arranged and constructed that there is no friction and no loss of power in whatever position the wind-wheel is placed. The pitmen are also so arranged that when one of them is at the dead-point in the revolution of the wheels F F', the other pitman has its bearing in a position at an angle to the dead-point. Thus, the power communicated to the wind-wheel is regular and uniform.

When the wind is too violent the shaft C is turned out of the wind, as may be desired.

The lower part of the pitman *e* remains in a fixed position, while the upper part turns at the swivel-joint *f*. The cap or disk H turns, with the pitman *g*, on the turn-table *d'*.

Having now fully described my invention, what I claim, and desire to secure by Letters Patent, is—

1. The shaft D, provided with the wheel F, having bearings on the turn-table, provided with the arm C, in combination with the compound crank *i*, the pitmen *e e'* and *g d*, the turn-table H, provided with the lips *l l*, clasp- ing the crown of the disk *d'*, all so constructed and arranged that the wind-wheel E may be turned to any point of the compass and allow the pitmen *e e'* and *g d* to operate equally well, all substantially as described, and for the purposes set forth.

2. The wheel F', the compound crank *i*, attached thereto, the pitman *e e'*, provided with the swivel *f*, and the pitman *d*, provided with the disk *d'*, in combination with the turn-table H and the pitman *g*, the compound crank *i*, the wheel F, all so constructed and arranged that while one pitman is at its dead-point in the revolution of the wheel, the other pitman shall have passed its dead-point, all substantially as described, and for the purposes set forth.

In testimony that I claim the foregoing I have hereunto set my hand this 3d day of October, 1876.

JOHN SMITH.

Witnesses:

J. B. HAYS,  
S. H. PALMER.