

M. J. SMITH, W. H. RYER, & W. W. CLARK.

MILK-PAN.

No. 187,059.

Patented Feb. 6, 1877.

Fig. 1.

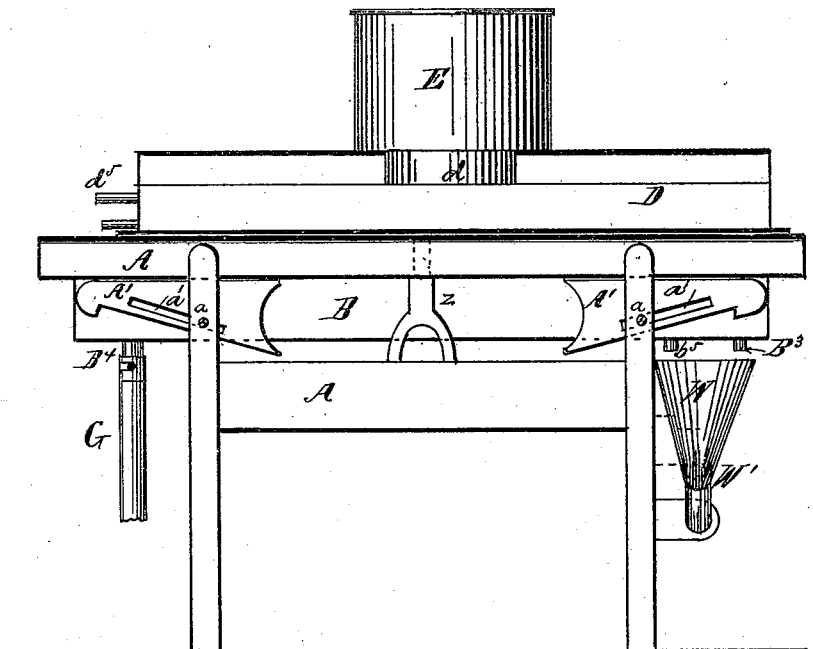
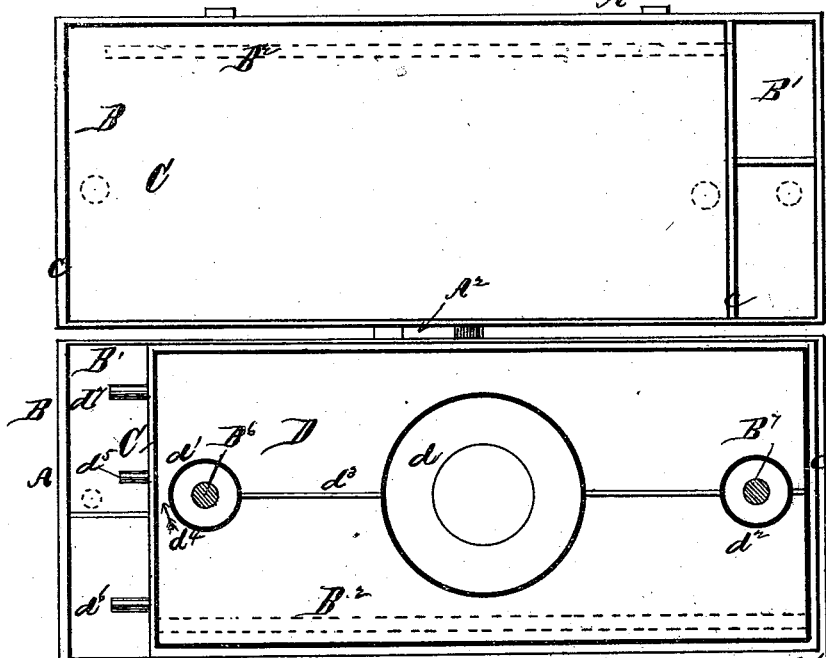

Fig. 11.



Witnesses:
 Franklin Bennett
 Richard Lerner.

Inventors:
 M. J. Smith
 W. H. Ryer
 W. W. Clark
 Per: Henry C. Lerner, A.T.T.

M. J. SMITH, W. H. RYER, & W. W. CLARK.

MILK-PAN.

No. 187,059.

Patented Feb. 6, 1877.

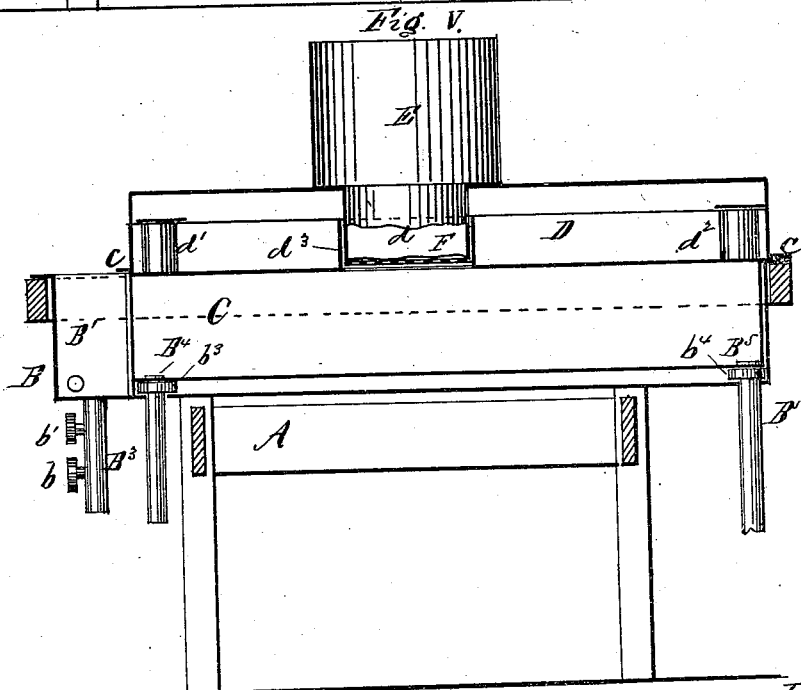
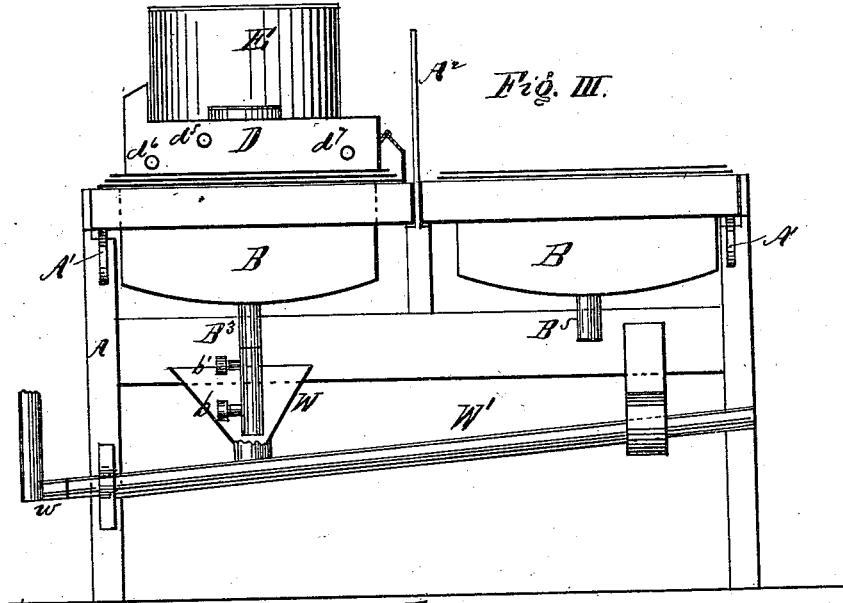

Witnesses:
Franklin Barrett
Richard Vermont

Inventors:
M. J. Smith.
W. H. Ryer.
W. W. Clark.
 Per *Henry Currier* Atty.

M. J. SMITH, W. H. RYER, & W. W. CLARK.

MILK-PAN.

No. 187,059.

Patented Feb. 6, 1877.

Fig. IV.

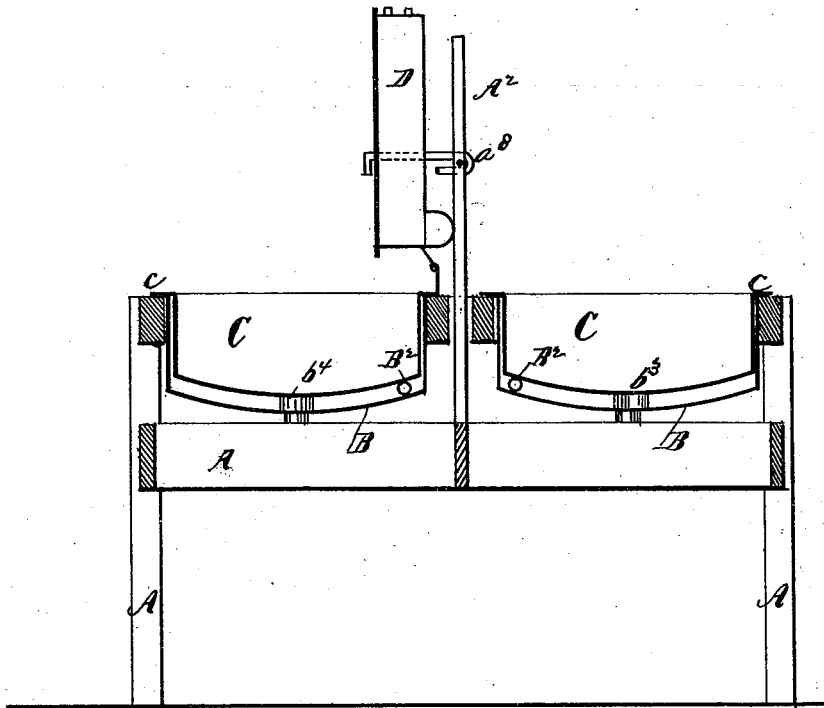

Witnesses:

Manfred Barrett
Richard Benson

Inventors:

M. J. Smith.
W. H. Ryer.
W. W. Clark.
Per Henry Gerner,
Atty.

UNITED STATES PATENT OFFICE

MAURICE J. SMITH, WILLIAM H. RYER, AND WHEELER W. CLARK, OF
CLARK'S FACTORY, NEW YORK.

IMPROVEMENT IN MILK-PANS.

Specification forming part of Letters Patent No. 187,059, dated February 6, 1877; application filed
May 18, 1876.

To all whom it may concern:

Be it known that we, MAURICE J. SMITH, WM. H. RYER, and WHEELER W. CLARK, all of Clark's Factory, in the county of Delaware and State of New York, have invented certain new and useful Improvements in Milk-Pans, the nature of which will be fully understood by reference to the accompanying drawings, which form part of this specification, and in which—

Figure 1 represents a side elevation of a complete machine constructed according to our invention. Fig. 2 is a general plan; and Fig. 3 an end elevation of the same. Fig. 4 shows a transverse section, representing the upper water-vessels turned up on edge and secured by the retaining-hook. Fig. 5 is a longitudinal elevation taken on the line X X of Fig. 2, and showing in elevation the water-outlet tube from the lower water-tray, with its outlet-aperture at different altitudes.

In each of these views, similar letters of reference are employed to indicate corresponding points wherever they occur.

A A represent the main framing, which, for convenience and economy, is adapted by preference to support two milk-pans and their cooling-tanks. Upon the frame A are supported two water-tanks, B, which are pivoted centrally on bearings Z, carried by the framing A, one of which is shown by Fig. 1, the water-tanks B being allowed a sliding or rocking motion on the central bearings or supports Z, except when held by the wedges A¹. The wedges A¹ are attached to the corner-posts of the frame A by means of bolts or pins a passing through the slots a'. The slots a' are of sufficient length to allow of the wedges A¹ being adjusted in position so as to cause either end of the tanks B to be tilted up or down at either end, in order to drain them of their contents. When both the wedges A¹, at each end of the machine, are fully drawn out they will hold the tanks B in a level position, as shown by Fig. 1. The water-tanks B are, by preference, rectangular, and of a length two or three times greater than their width, and of a depth, say, of one-quarter of their width. The bottoms of the

tanks B are, by preference, concave in cross-section, and at one end they are provided with a small chamber, B¹, for containing hot or cold water or ice, as required, to heat or cool the milk in the pan. From the chamber B¹ a pipe, B², (shown in Figs. 2 and 4,) conducts the water to the opposite end of the tank B, whence it will flow back and escape from the pipe B³, which has outlets b b¹ at different heights. The tube B³ fits into an aperture in the bottom of the tank B in a similar manner to the plug, so that when it is removed this aperture will allow all the water in the tank B to be drawn off. There are two other apertures in the bottom of the tank B, to which tubes B⁴ and B⁵ are connected. These tubes B⁵ and B⁴ extend up into the tray or tank B one or two inches, more or less, and at their upper ends they are provided with rubber packing-rings b³ b⁴.

The milk-pan C fits into the water-tank B, and rests upon the outer edges of the same by means of flanges c c formed on the upper and outer edges of the pan C. Small hooks or catches c', carried by the framing A, are adapted to be brought into position to hold the pan C firmly down upon the water-tank B, and also upon the rubber packing-rings b³ b⁴, in order to form a water-tight joint between the top end of the tubes B⁴ B⁵ and the bottom of the milk-pan. The bottom of the milk-pan C is, by preference, formed concave, to correspond with the shape of the water-tank B. By this construction the contents of the milk-pan C will be easily run out through the central apertures at the bottom of the pan. B⁶ B⁷ are plugs for the purpose of stopping the apertures at the bottom of the milk-pan C, so as to prevent the escape of its contents when required.

When either of the plugs B⁶ B⁷ is removed, the contents of the milk-pan C can be withdrawn at that end, as will be hereinafter more fully explained.

Above the milk-pan C, and resting upon it, is another water-tray, D. This water-tray D has a central opening, d, through which the milk is passed down from the strainer E to the milk-pan C. There are also two openings, d¹ d²,

through the water-tray D, which afford access to the plugs B⁶ B⁷. The openings d^1 d^2 are surrounded by a wall or rim, in order to prevent the water from the upper tray passing down into the milk-pan C below it. The tray D is also provided with a partition, d^3 , as shown in Fig. 2, which divides the same into two compartments, which are connected together by a passage, d^4 .

The water-tray D is hinged at one side to the top central beam of the frame A, in order that it may be turned up on its edge when required to gain access to the milk-pan C. It is secured in that position by a hook, a^8 , which is attached to the central post A² of the frame A.

A pipe, d^5 , supplies hot or cold water to the tank D, as required, and when the water thus supplied passes through the compartment into which it first enters, it passes through the opening d^4 into the other compartments, and escapes therefrom through either one of the outlet-pipes d^6 d^7 . The outlet-pipes d^6 d^7 are set at different heights, so as to use either, as required, for the purpose of keeping more or less water in the tank or tray D, as required. The circular walls d^1 d^2 are provided with covers, which should be kept constantly closed, except when it is required to remove or replace in position the plugs b^6 b^7 .

By keeping these openings closed the light is kept from the surface of the cream, which is thereby prevented from being bleached. To the central opening d is attached a funnel, E, into which the milk is first poured, and from which it passes down to the milk-pan C, through the opening d .

A cloth or strainer, F, Fig. 5, is placed over the opening d , and between it and the funnel E, for the purpose of straining the milk and freeing it from any mechanical impurity. A pipe, G, is attached to the discharge-tube B⁴ by means of a slot and lip-clutch.

The tube B³ discharges into the funnel W, which is fastened to the pipe W', for leading off to suitable reservoirs the milk or cream that is discharged from the pan C. The water-discharge pipe b^3 is also connected with the tube or pipe W', so as to run the water from the water-tank into this common dis-

charge-pipe, when it is not used to discharge the milk or cream, in order to keep this common discharge-pipe from becoming foul, as it would if only milk or cream were run through it. The discharge end w of the pipe W' is formed with a swivel, in order that it may be turned in different directions, so as to lead to different vessels, as required, for the discharge of the different fluids passing through it.

A movable pipe is arranged to be attached to the outlet-pipes d^6 d^7 , when required, so as to lead into the top end of the waste-pipe, in order to run all the waste or discharge water through that tube. The milk-pan C having been filled through the funnel E, as described, and the milk having remained in the pan long enough for the cream to rise, the milk will first be drawn off by slipping one of the wedges A¹ gently back, so as to allow the pan to tip down on that end. The plug B⁶ or B⁷, as the case may be, is then withdrawn, and by gently tipping the pan down on that end, the milk will be allowed to run out through the tube B⁴ or B⁵, as the case may be. After the milk has been run out from under the cream, the aperture through which it passed from the pan will be closed by the replacement of its plug, and then the other discharge-plug will be removed at the opposite end, and the cream drawn out in the same manner as the milk was.

Having thus described our invention, what we claim as new, and desire to secure by Letters Patent, is—

1. The combination, with the frame A, provided with adjustable wedges A¹ and bearings Z, of the rocking water pans or tanks B, substantially as shown and described.

2. The combination, with the tank B, provided with tubes B⁴ B⁵ and packing-rings b^3 b^4 , and the milk-pan C and plugs B⁶ B⁷, of the water-tank D, having openings d^1 d^2 , substantially as and for the purpose set forth.

M. J. SMITH.
WILLIAM H. RYER.
WHEELER W. CLARK.

Witnesses:

REED DUMOND,
OLNEY A. SMITH.