

J. T. ANDERSON.
TYPE-WRITERS.

No. 187,080.

Patented Feb. 6, 1877.

Fig. 1.

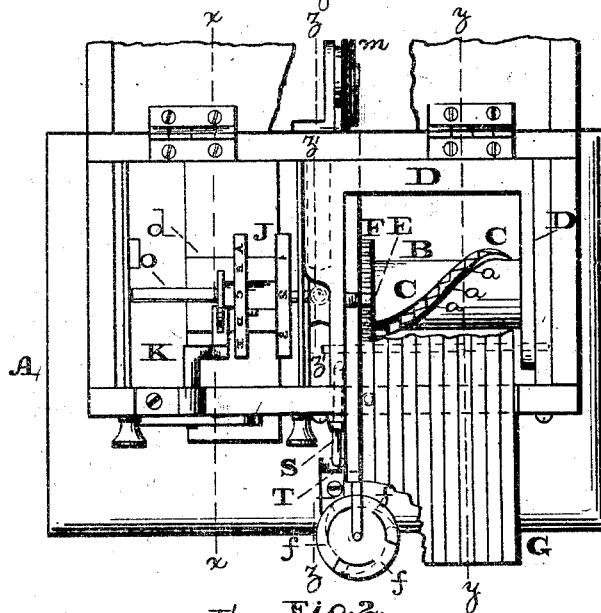

Fig. 2.

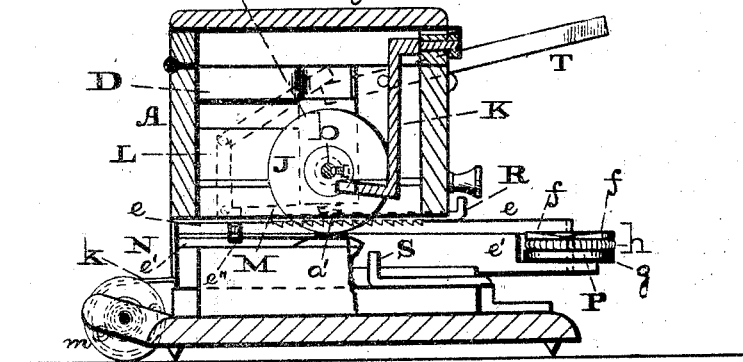
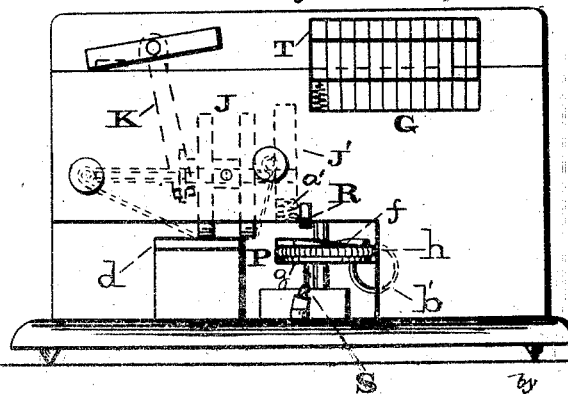

Fig. 3.



Witnesses.

John F. Brown,
Robt. Grant.

Inventor:

J. T. Anderson

John F. Brown
Attorney.

J. T. ANDERSON.
TYPE-WRITERS.

No. 187,080.

Patented Feb. 6, 1877.

Fig. 4.

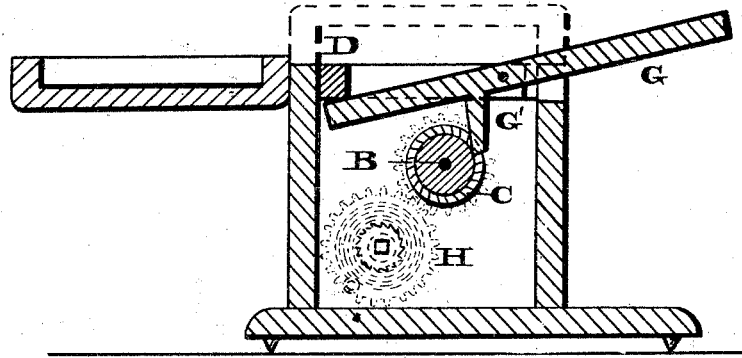

Fig. 5.

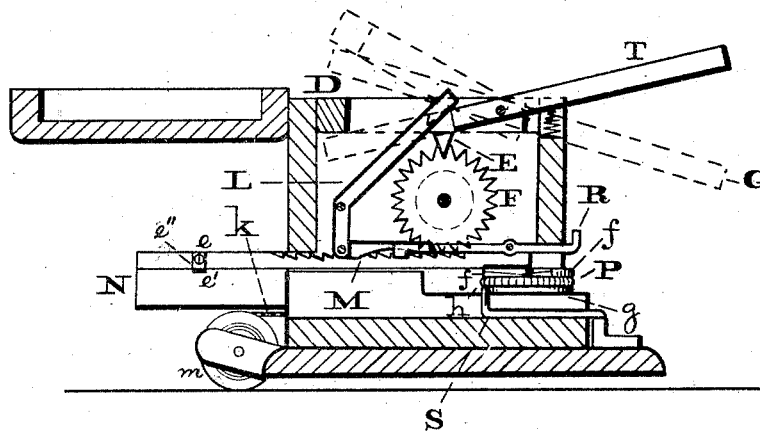

Fig. 6.

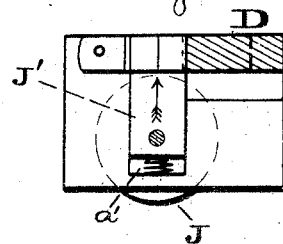
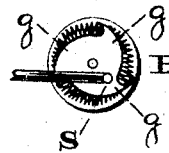

Fig. 7.



Witnesses:
Lewis C. Brown,
No. P. Grant.

Inventor:
J. Tate Anderson

by *John A. Dieckmann*
 Attorney.

UNITED STATES PATENT OFFICE.

J. TATE ANDERSON, OF PHILADELPHIA, PENNSYLVANIA.

IMPROVEMENT IN TYPE-WRITERS.

Specification forming part of Letters Patent No. 187,080, dated February 6, 1877; application filed October 13, 1876.

To all whom it may concern:

Be it known that I, J. TATE ANDERSON, of the city and county of Philadelphia, and State of Pennsylvania, have invented a new and useful Improvement in Type-Writing Machines; and I do hereby declare the following to be a clear and exact description of the nature thereof, sufficient to enable others skilled in the art to which my invention appertains to fully understand, make, and use the same, reference being had to the accompanying drawings, making part of this specification, in which—

Figure 1 is a top or plan view of the machine embodying my invention. Fig. 2 is a transverse section in line *x x*, Fig. 1. Fig. 3 is a front view thereof. Fig. 4 is a transverse section in line *y y*, Fig. 1. Fig. 5 is a transverse section in line *z z*, Fig. 1. Fig. 6 is a transverse section in line *z' z'*, Fig. 1. Fig. 7 is a bottom view of the feed-wheel.

Similar letters of reference indicate corresponding parts in the several figures.

My invention consists of a mechanically-operated type-wheel, the rotation of which is controlled by keys, so as to properly present the characters of the type at the place where the impression is to be made, said wheel being connected to a drum which carries a spirally-arranged toothed rib and a spur-wheel, in combination with a frame having a pawl, which is to be raised to allow the rotation of the type-wheel, and keys having teeth which engage with the toothed rib, so as to limit the rotation of said type-wheel.

It also consists of a rotary type-wheel automatically rising, so as to elevate the type from the paper in the intervals between the impressions, in combination with a gravitating frame for imparting blows to the type-wheel.

It also consists of a novel sheet-holder and operating mechanism.

It further consists of an automatically-operating feed-wheel, which has inclines and cams on opposite sides, and operates with a pin or stud for separating the bars of the sheet-holder and advancing the sheet.

It also consists of means for operating the sheet-holder without imparting motion to the type-wheel.

Referring to the drawings, A represents a

casing or box, within which is mounted a horizontal drum, B, having on its perimeter a flange or rib, C, which extends in a spiral direction, and is formed with serrations or teeth *a*, connected or separated. To the upper portion of the casing A, and above the drum B, there is hung a frame, D, on whose under face, at one side, is formed a pawl, E, which is adapted to engage with a toothed wheel, F, secured to the drum B. G represents keys, having downwardly-projecting teeth G', and which, in the present case, have their axis on the axis of the frame D, and their inner ends engage with the frame, so that, by depressing the outer or exposed ends of the keys, the inner ends thereof will elevate the frame, and consequently lift the pawl E from the toothed wheel F.

The drum B will be geared to suitable clock-work or mechanical movement, (illustrated at H, Fig. 4,) so that power will be communicated to the drum, thus causing rotation thereof.

The axis of the drum B is extended, as at *b*, and on the extension is fitted a type-wheel, J, which consists of two disks, one for letters, and the other for figures, or such characters as are to be printed. This wheel rotates with the drum B, but it is connected to its axis by a feather-joint, so as to be permitted to slide thereon, whereby either disk may be brought over a bed, *d*, into proper position for printing. The axis of said type-wheel has a rising and falling motion, and for this purpose it is mounted in a sliding piece, J', which is fitted to guides in the casing, and pressed upward by a spring, *a'*, suitably applied. A hinged lever, K, is mounted on the casing A, and one end is forked, so as to engage with a collar on the hub of the type-wheel, and the other end is provided with a handle, so that said type-wheel may be properly shifted.

L represents an elbow-lever, which is pivoted to the casing A in such position adjacent to the drum B, that its upper limb will be engaged by the pawl E when the frame D is elevated. The lower limb carries a pawl, M, which engages with a rack formed on the sheet-holder N, which consists of two bars, *e e'*, arranged one above the other, the lower bar carrying a feed-wheel, P, whose upper face is formed of a series of inclines, *f*, and the pe-

riphery near the lower edge is formed of a series of cams, *g*. The periphery also carries an encircling coiled spring, *h*. The front end of the upper bar rests on the inclines *f* of the feed-wheel, and it is fitted to the axial pin of said feed-wheel, so that by rotation of the feed-wheel the inclines will cause alternate rising and falling of the upper bar.

To the sheet-holder N there is connected a cord, *k*, which is wound on and unwound from a reel, *m*, mounted adjacent to the rear end of the lower bar *e* of the paper-holder, and having a spring attached to its axis, so that the tendency is to wind the cord on the reel, and, consequently, return the paper-holder to its first position, but as the pawl M of the elbow-lever L engages with the rack or teeth of the paper-holder, and forces out the latter, I provide a throw-off lever, R, which is pivoted to the casing A, and so located that at the proper time, by depressing said lever R, the pawl M will be elevated, thus releasing the holder. The spring of the reel causes the winding of the cord *k*, which operation, consequently, draws in or returns the paper-holder to its normal position. (Shown in Figs. 1 and 5.)

Adjacent to the paper-holder is secured an upwardly-projecting pin or stud, S, which is so located that, as the sheet-holder is returned to its first position, the feed-wheel P will strike said pin or stud, and thus receive a partial rotation.

T represents a lever, which is pivoted to the upper portion of the casing A, and its inner end is in, or adapted to come in, contact with the upper limb of the elbow-lever L, so as to impart motion to said lever L independent of the frame D.

There will be as many keys as there are letters or characters to be printed, and numbers or figures will be marked on the same keys, so as to dispense with an extra set therefor.

The clock-work being suitably wound, it will impart power to the drum B; but the latter is prevented from rotation by the engagement of the pawl E with the toothed wheel F on said drum B. As soon as a key is depressed it elevates the frame D, and clears the pawl E of the wheel F, and thus permits the rotation of the drum, the piece J' rising and elevating the type-wheel; but the tooth G of the depressed key, having approached the drum, comes in contact with the relative tooth *a* of the spiral rib or flange C, and thus stops the drum. Now, as the type-wheel has been rotated and stopped by the engagement of the tooth G' with the tooth *a* of the flange C, the periphery of the type-wheel at the point over the printing-bed will present to said bed a letter or figure of the same character or denomination as that indicated by the depressed key, whereby the type is in position for printing. The key is now let go, and the frame D falls, in which motion it strikes the piece J', and imparts a blow to the type-wheel, so that

the sheet resting on the bed *d* will receive the impression.

The sheet will be passed between the bars *e-e'*, one side being held between the coiled spring and adjacent portion of the feed-wheel, and the other side in contact with a suitable guide, *e''*. One of the keys G will be depressed for each letter or figure to be printed, and the drum B will immediately rotate, the limit thereof being due to the tooth of the key engaging with the tooth of the spiral rib or flange with which it is directly in line, so that the type-wheel will rotate and be stopped at the proper time, in order to bring the proper letter or figure opposite to the bed *d*, it being understood that the keys, teeth of the spiral rib or flange, and type-wheel, work in harmony.

Whenever the frame D is elevated, the elbow-lever L will be operated so that its pawl M will move out the paper-holder the distance of one tooth; consequently the sheet is placed to have the next impression made thereon. Then the frame falls, and the impression is made.

When the sheet is printed across to the desired extent, the lever R is operated, so as to throw off the pawl M from the teeth of the sheet-holder, and, owing to the spring of the reel *m*, the cord *k* is wound thereon, and returns the sheet-holder to its first position. In this return motion the shoulder of one of the cams *g* of the feed-wheel strikes the pin or stud S, whereby the wheel receives a partial rotation, and thus carries the sheet forward one space, so that it is in proper position for the printing of the next line, the bars *e* rising by the action of the inclines *f*, so as to permit the passage of the sheet.

When the sheet is to be moved laterally, for spacing or other purposes, without moving the drum and type-wheel, the lever T will be operated, whereby, by means of the elbow-lever L, in contact therewith, the pawl M will impart advancing motion to the sheet-holder to the desired extent. Then, if it is desired to space in the direction from top to bottom of the sheet, the lever R will be operated so that the sheet-holder is returned, the feed-wheel rotated, and the sheet advanced in a manner similar to that previously stated.

b' represents a basket or arms, which, secured to the sheet-holder, constitute means for receiving and holding a roll of paper, in case it is necessary to employ paper in roll.

It will be noticed that, during the operation of printing, the impressions will be made on the upper face of the sheet, so that the printing can be viewed as it progresses.

Having thus described my invention, what I claim as new, and desire to secure by Letters Patent, is—

1. The mechanically-operated drum B, with spirally-arranged toothed rib C, and spur-wheel F, in combination with the keys G with teeth G', and the frame D with pawl E, substantially as and for the purpose set forth.

2. The rotary type-wheel, in combination with the spring-elevated bearing-piece *J'*, and gravitating-frame *D*, substantially as and for the purpose set forth.

3. The sheet-holder bars *ee'*, in combination with the lever *L*, with pawl *M*, and the elevating-lug *F*, substantially as and for the purpose set forth.

4. The feed-wheel *P*, with inclines *f* and cams *g*, in combination with the sheet-holder

N and pin or stud *S*, substantially as and for the purpose set forth.

5. The sheet-holder and lever *L*, in combination with the lever *T*, for operation of the sheet-holder independent of the keys *G*, substantially as and for the purpose set forth.

J. TATE ANDERSON.

Witnesses:

JOHN A. WIEDERSHEIM,
JNO. A. BELL.