

M. C. CHAMBERS.

SLIDE-RESTS FOR SPINNING-TOOLS.

No. 187,098.

Patented Feb. 6, 1877.

Fig. 1.

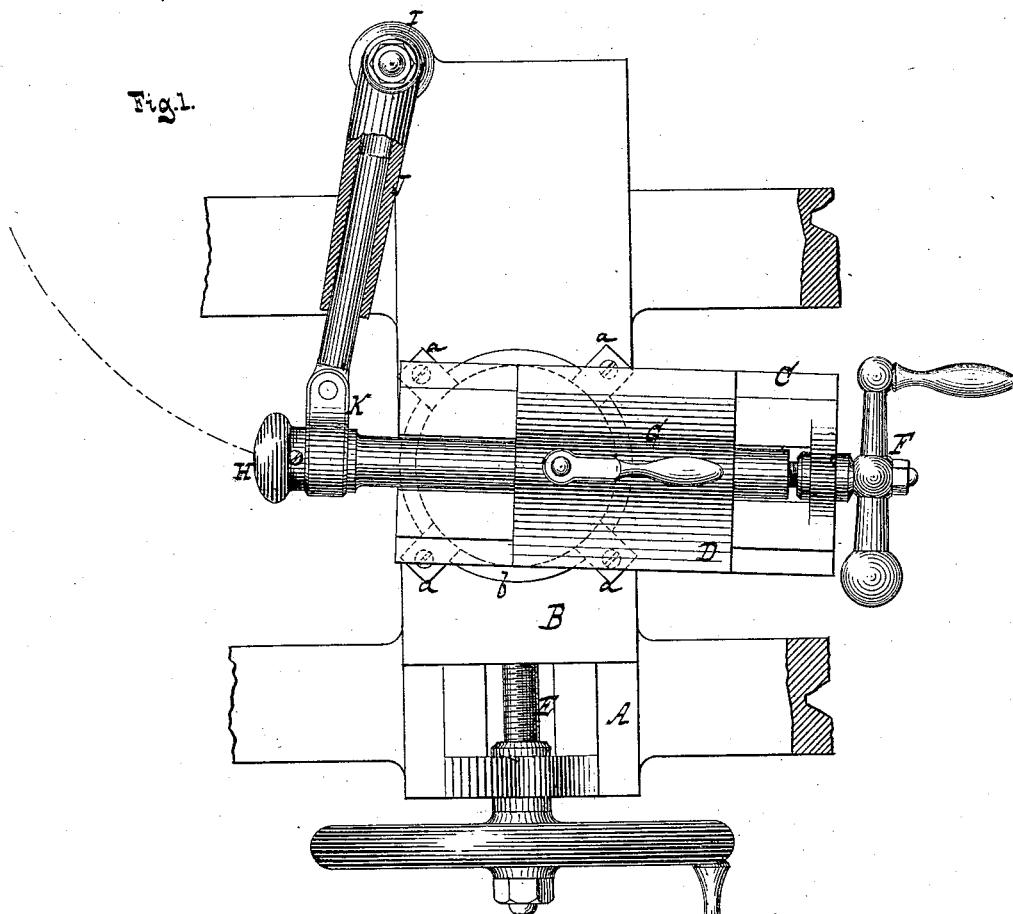
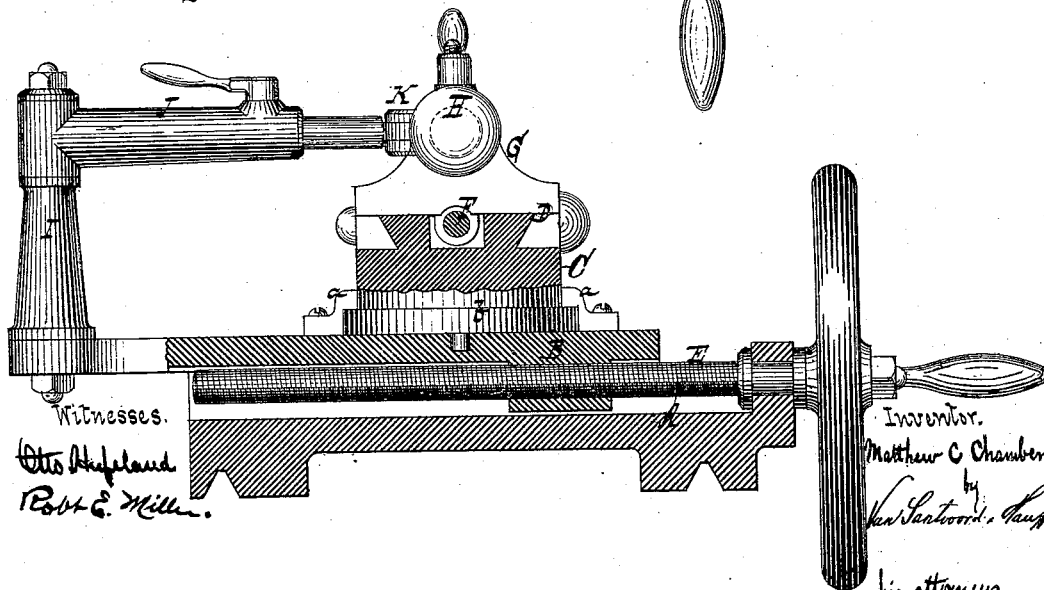

Fig. 2.



Witnesses.

Otto Hufeland
Robt. E. Miller.

Inventor.

Matthew C. Chambers
by
Van Santvoord & Huff
his attorneys

UNITED STATES PATENT OFFICE.

MATTHEW C. CHAMBERS, OF GREEN POINT, NEW YORK.

IMPROVEMENT IN SLIDE-RESTS FOR SPINNING-TOOLS.

Specification forming part of Letters Patent No. **187,098**, dated February 6, 1877; application filed August 3, 1876.

To all whom it may concern:

Be it known that I, MATTHEW C. CHAMBERS, of Green Point, in the county of Kings and State of New York, have invented a new and useful Improvement in Slide-Rests, which improvement is fully set forth in the following specification, reference being had to the accompanying drawing, in which—

Figure 1 represents a plan or top view. Fig. 2 is a sectional front view.

Similar letters indicate corresponding parts.

This invention consists in the combination of a swinging arm and brace with the tool-stock of a slide-rest said tool-stock being secured to the secondary carriage, the guideways of which are connected to the main carriage by a swivel-joint, so that in moving the tool-stock in or out on its guideways the tool is compelled to describe a curve, the radius vector of which is determined by the length of its swinging arms and by the distance of the point or working-face of the tool from the center of motion of the guideways of the secondary carriage, and by these means the operation of spinning or turning articles of certain curves is materially facilitated. The swinging arm is so constructed that it can be lengthened or shortened to accommodate the motion of the tool to different curves.

In the drawing, the letter A designates the guideways for the main carriage B of an ordinary slide-rest. On the surface of this slide-rest are secured a series of lugs, *a*, which catch over a flanged ring, *b*, which is rigidly attached to the under surface of the guideway C of the secondary carriage D. The carriages B and D are moved on their guideways by screws E and F, respectively.

On the secondary carriage is firmly secured the tool-stock G, in which the tool H is fastened by a set-screw, or any other suitable means.

In the drawing I have shown a burnishing-tool of that class generally used in the operation of spinning articles of sheet metal, but the form of the tool may be changed to conform to the work to be accomplished.

From the main carriage B rises a standard, I, to which is attached an arm, J, that swings freely in a horizontal plane. This arm is

composed of two sections, fitted together on the principle of a telescope, or in any other suitable manner, whereby said arm can be lengthened or shortened. The outer end of the swinging arm is pivoted to a brace, K, which, in the example shown in the drawing, embraces the tool H, but which may be connected to the tool-stock instead of connecting it directly to the tool. By turning the screw F of the secondary carriage the point or head of the tool H is caused to describe a curve, the radius vector of which is determined by the length of the swinging arm, and by the distance of said point or head from the center of motion of the secondary carriage, and thus by the operation of the single screw F the tool is compelled to follow a certain fixed path, whereby the operation of spinning or turning curved articles can be accomplished with great economy in labor.

In order to accomplish the same operation by means of an ordinary slide-rest, not provided with my improvement, the screws E and F of both carriages of the slide-rest have been manipulated with great care, and it requires considerable practice to produce good work.

My improvement is designed particularly for spinning hollow articles of sheet metal, such as dish-pans, bowls, or other vessels of a similar nature; but it can also be used with advantage for turning or spinning any other article with a curved face.

What I claim as new, and desire to secure by Letters Patent, is—

The combination of a swinging arm or brace with the tool-stock of a slide-rest, said tool-stock being secured to the secondary carriage D, the guideways of which are connected to the main carriage B, by a swivel-joint, the whole being constructed and operated substantially as and for the purpose herein shown and described.

In testimony that I claim the foregoing I have hereunto set my hand and seal this 25th day of July, 1876.

MATTHEW C. CHAMBERS. [L. s.]

Witnesses:

W. HAUFF,
E. F. KASTENHUBER.