

W. H. COLLETT.
COLTER-PLOW.

No. 187,106.

Patented Feb. 6, 1877.

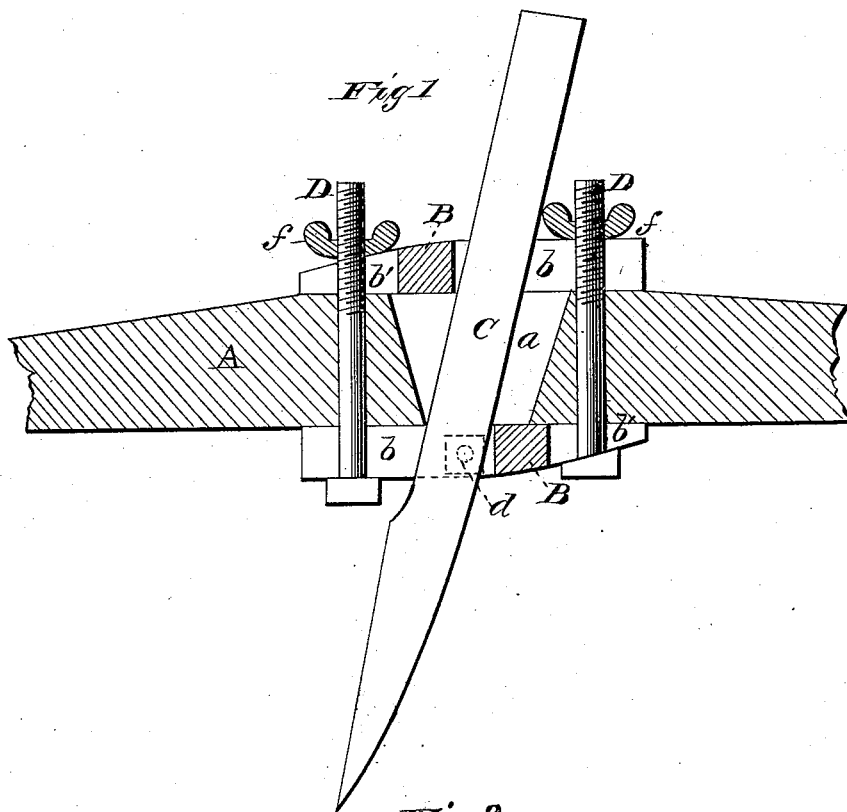
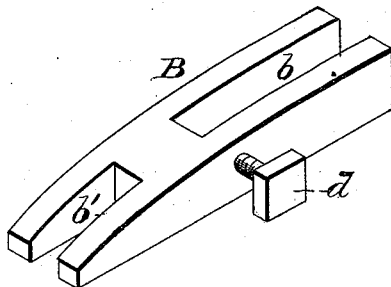

Fig 2



WITNESSES
Frank L. Ouraud
Henry N. Miller

INVENTOR
Wm H. Collett
By *Hander Mason*
Attorneys

UNITED STATES PATENT OFFICE.

WILLIAM H. COLLETT, OF JACKSON, TENNESSEE.

IMPROVEMENT IN COLTER-PLOWS.

Specification forming part of Letters Patent No. **187,106**, dated February 6, 1877; application filed June 20, 1876.

To all whom it may concern:

Be it known that I, WILLIAM H. COLLETT, of Jackson, in the county of Madison and in the State of Tennessee, have invented certain new and useful Improvements in Colter-Plows; and do hereby declare that the following is a full, clear, and exact description thereof, reference being had to the accompanying drawings, and to the letters of reference marked thereon, making a part of this specification.

The nature of my invention consists in attaching a colter to a plow-beam, as herein after more fully set forth.

To enable others skilled in the art to which my invention appertains to manufacture and use the same, I will now proceed to more fully describe the same, reference being had to the accompanying drawings, forming a part of this specification, in which—

Figure 1 represents a longitudinal section of a plow-beam, showing the colter and mode of securing the same to the beam. Fig. 2 represents a perspective view of one of the metallic colter-holders.

A represents a plow-beam, which is provided with a vertical slot, *a*, made larger at the top than at the bottom, in V-shaped form, as shown, so that the colter, when admitted, can be moved backward and forward, and allow it to be placed at different angles. By this construction the colter can be brought in contact with a half-shovel, and form by such combination a turning-plow. Arranged on the upper and lower part of the beam, above and below this slot *a*, are metallic castings B, each of which consists of a bar the width (or about the width) of the beam, and long enough to extend beyond the walls of the slot in the same. Each bar or holder is made substan-

tially as shown in Fig. 2, and has a short open-end slot, *b'*, at one end and a longer open-end slot, *b*, at the other. C represents the colter, the stem of which is passed through the long slots *b b* in the holders and through the slot *a* in the beam, as seen in Fig. 1. D D are two vertical headed bolts, which pass through the slots in the holders B and through the beam. Thumb screws *f f* on the upper ends of the bolts clamp the holders to the beam, and set-screws *d* on each holder secure the colter in position to the holders. This arrangement allows the colter to be set at any desired angle with respect to the beam, and dispenses with the usual wedges or keys for securing the colter.

The metallic colter-holders also serve as braces or stays to support the plow-beam at the part weakened by forming the slot in the same.

I am aware of Letters Patent No. 176,138, granted to A. E. Jester, April 18, 1876, and hereby disclaim such invention.

Having thus fully described my invention, what I claim as new, and desire to secure by Letters Patent, is—

The combination of the beam A, having the V-shaped slot *a*, the colter C, and metallic holders B B, having open-ended slot at each end, the set-screws *d d* above and below on opposite sides, the bolts D, and nuts *f*, all constructed substantially as and for the purposes herein set forth.

In testimony that I claim the foregoing I have hereunto set my hand this 8th day of February, 1876.

W. H. COLLETT.

Witnesses:

S. T. LINDSEY,
JAS. K. STEPHENS.