

E. G. GODDARD.
CAR-STARTER.

No. 187,127.

Patented Feb. 6, 1877.

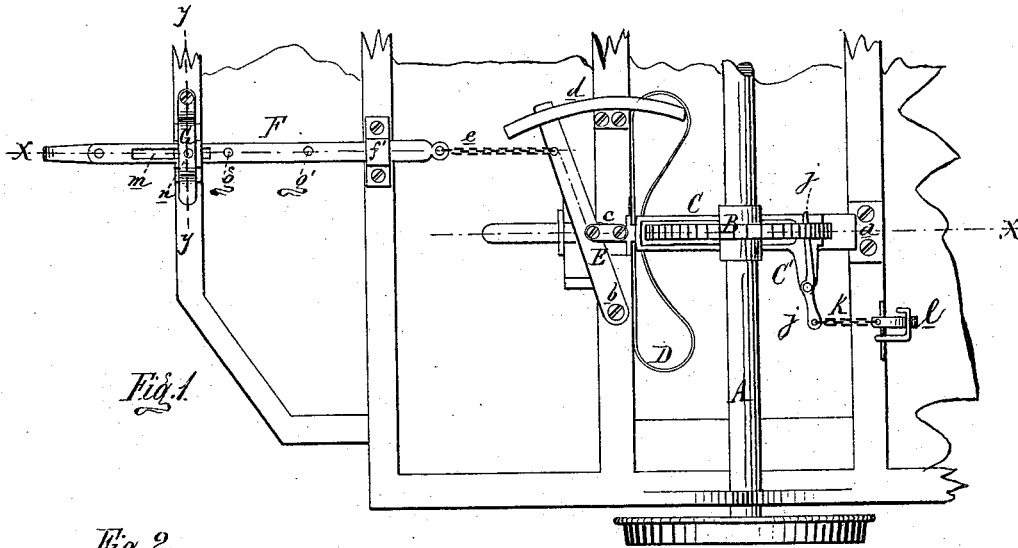

Fig. 2.

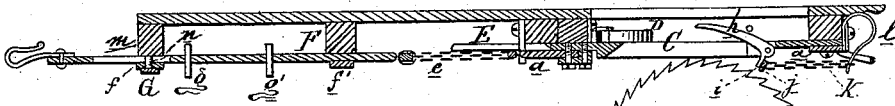

Fig. 5.

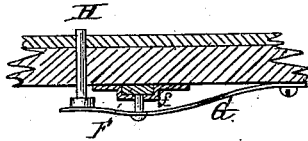

Fig. 3.

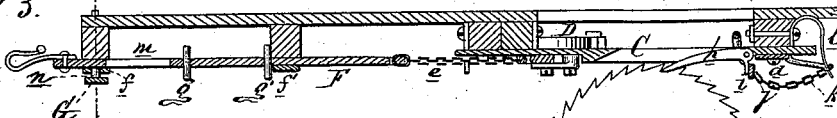
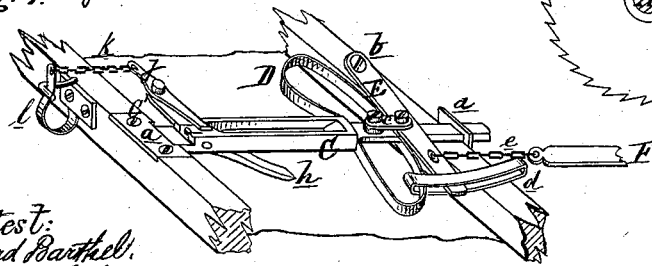

Fig. 4.



Attest:
Edward Parthel.
Thos. S. Day.

Inventor:
E. G. Goddard
By atty
Thos. S. Sprague

UNITED STATES PATENT OFFICE.

EZRA G. GODDARD, OF EAST SAGINAW, MICHIGAN.

IMPROVEMENT IN CAR-STARTERS.

Specification forming part of Letters Patent No. 187,127, dated February 6, 1877; application filed September 5, 1876.

To all whom it may concern :

Be it known that I, EZRA G. GODDARD, of East Saginaw, in the county of Saginaw and State of Michigan, have invented an Improvement in Car-Starters, of which the following is a specification :

The nature of my invention relates to an improvement in car-starters of that class wherein the draft is temporarily applied to the axle, through a ratchet and pawl, until the axle is put in rotation ; and its object is to interpose a lever between the draw-bar and the pawl, in order to let the team travel a greater distance, and expend less power in starting the car.

The invention consists, mainly, in the combination of a lever with the draw-bar and the sliding pawl-frame ; also, in the combination of certain devices for throwing the pawl into gear, and for retaining it out of gear with the ratchet, as more fully hereinafter set forth.

Figure 1 is a bottom plan of a horse-car, or a portion thereof, showing the positions of the several parts when the draw-bar is under tension or draft. Fig. 2 is a longitudinal vertical section taken along the angular line *xx*, showing the parts in their relative positions when the draw-bar is under draft. Fig. 3 is a similar section, showing the positions of the several parts when the draw-bar is fully retracted by the spring to allow the pawl to engage with the ratchet. Fig. 4 is an inverted perspective view of the sliding pawl-frame, the pawl and its attachments, the draft-spring, and the lever interposed between the pawl-slide and the draw-bar ; and Fig. 5, a vertical section on the line *yy* in Figs. 1 and 3.

In the drawing, A represents one of the axles of a horse-car, transversely journaled under the sills of its bed. B is a ratchet on the axle at one side of the draft, and is straddled by a slot in a pawl-slide, C, having a longitudinal play in stirrups *aa* under the transverse girts of the bed-frame. D is an elliptic spring, interposed between a block on the upper side of the slide C, and the girt next in front thereof, thus tending to push back said slide. E is a lever, pivoted by a bolt, *b*, at one end to the under side of a girt of the car-bed, and, by a link, *c*, near the middle, to the pawl-slide, its free end playing in a segment-

shaped supporting-guide, *d*, under the car-bed. Near this end it is connected by a short chain, *e*, with the inner end of the draw-bar F, sliding in stirrups *ff*. A pin, *g*, arrests its extreme forward movement, and another pin, *g'*, arrests its extreme rearward movement.

In the rear end of the slot of the slide C there is pivoted a pawl, *h*, having a pendent lug, *i*, near the heel, and at this point the said slide has a lateral projection, *c'*, under the end of which is pivoted a lever, *j*, one end of which comes behind the lug *i*, while the other is, by a short chain, *k*, connected with the end of a C-spring, *l*, fastened behind the next cross-sill back of it, and the tendency of which is to throw up the pawl out of engagement with the ratchet until the chain *k* is slacked up by pushing back the draw-bar and slide as far as the stop-pin *g'* will allow, as seen in Fig. 3, in which case the said pawl will drop onto the ratchet, but otherwise the said pawl will be lifted up, as seen in Figs. 2 and 4. Once drawn out far enough to lift up the pawl, the draw-bar is prevented from receding far enough to release it, until desired to use it in starting the car, by the following means :

Under the platform the draw-bar has a longitudinal slot, *m*, cut in it. A leaf-spring, G, is secured at one end under the front girt of the platform, and carries a pin, *n*, which projects up through a hole in the stirrup *f* and into the slot *m* when the draw-bar is drawn out, but from which it may be ejected by pressing down a foot-pin, H, resting on the free end of the spring G, and projecting up through the platform. If the driver desires to engage the pawl with the ratchet he presses down this pin H, when the spring D will act to throw back the draw-bar and the slide far enough to let the pawl drop onto the ratchet ; as soon as the draw-bar is drawn out, in the advance of the car, to draw up the pawl, the pin *n* will enter the slot *m* and prevent the draw-bar from receding again enough to re-engage the pawl. A hood or guard should be placed on the platform to prevent the foot-pin from being accidentally pushed down. By having the draft come upon the spring D, the horses' shoulders are less liable to be collar-galled, as the spring eases up the shock of a sudden pull in start-

ing forward, and, once in motion, the strain is a steady one, but yielding to all changes of speed or resistance.

I do not wish to be confined to the particular devices shown for automatically throwing the pawl into gear with the ratchet, and for disengaging it therefrom, as it is evident that a great variety of devices or combinations of devices may be employed, any one of which would accomplish the purpose.

What I claim as my invention is—

1. The slotted slide C, carrying the pawl *h*, adapted to engage with and give an impulse to the ratchet B on the axle, the spring D, le-

ver E, and draw-bar F, in combination with a means for automatically disengaging said pawl from the ratchet, and a means for arresting the full retraction of said draw-bar, substantially as described.

2. The combination, with the slotted slide C C', ratchet B, and spring D, of the pawl *h i*, lever *j*, chain *k*, and spring *l*, all constructed and arranged substantially as described and shown.

EZRA G. GODDARD.

Witnesses:

JOHN J. FLOOD,
JAMES MACK.