

H. G. WOOD.
ROTARY ENGINE.

No. 187,211.

Patented Feb. 6, 1877.

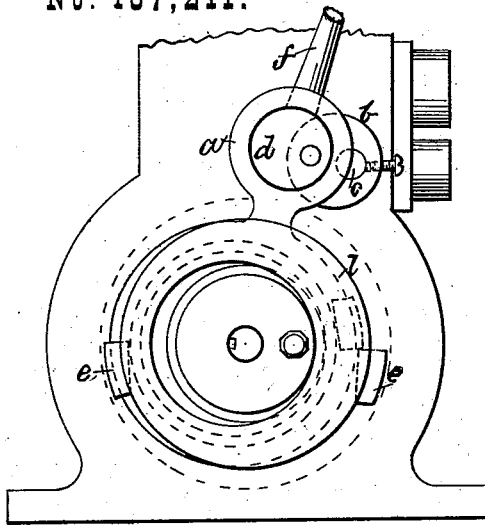

Fig. 10.

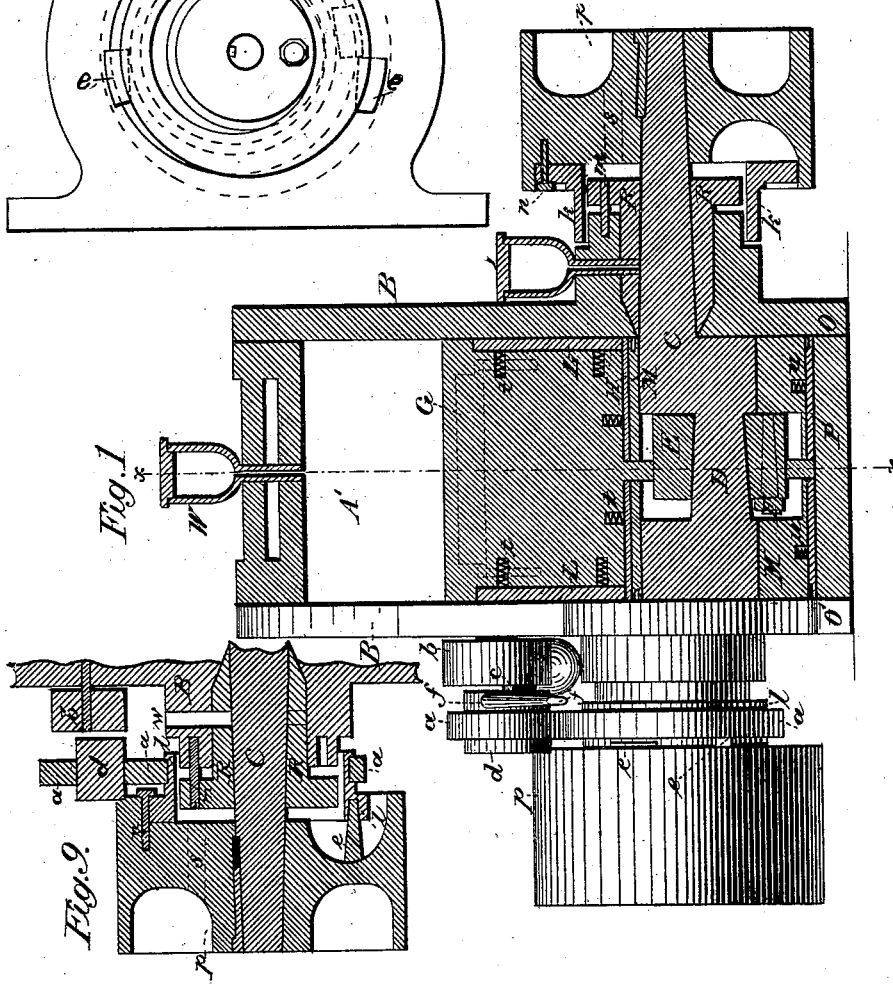

Fig. 9.

Attest:
D. S. Stuart.
L. Hannay.

Inventor:
Hermon G. Wood
by Amos Wallum
Atty.

H. G. WOOD.
ROTARY ENGINE.

No. 187,211.

Patented Feb. 6, 1877.

Fig. 3.



Fig. 4.



Fig. 6.

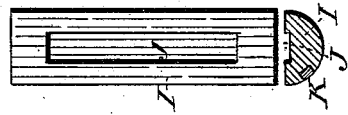

Fig. 8.



Fig. 5.

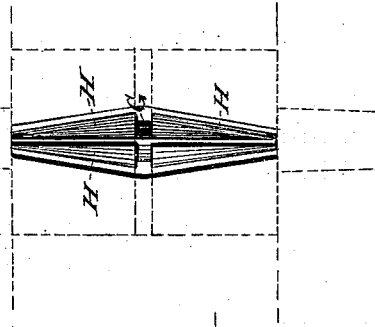

Fig. 7.

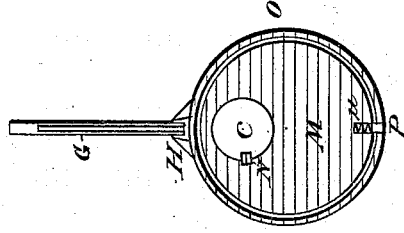
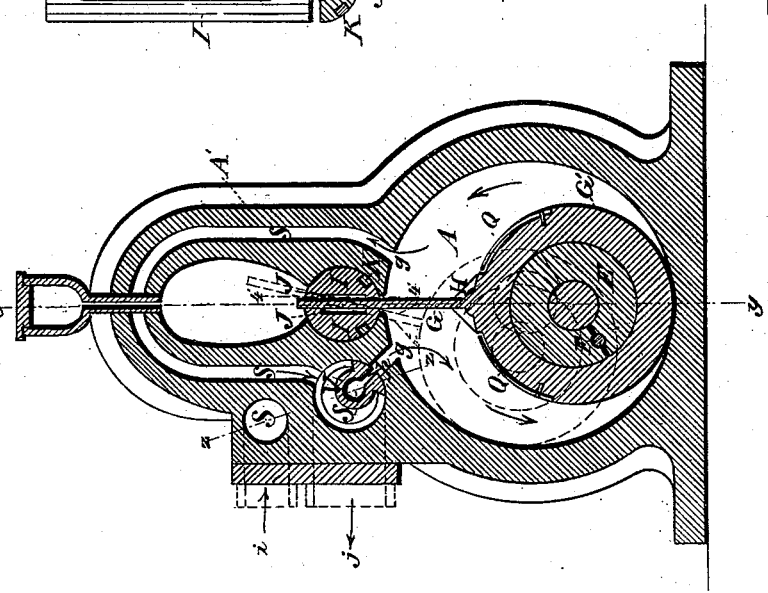

Fig. 2.



Attest:
D. G. Stuart
P. Hamay

Inventor:
Hermann Wood.
by Amelbalm
Atty.

UNITED STATES PATENT OFFICE.

HERMON G. WOOD, OF SHARON, PENNSYLVANIA.

IMPROVEMENT IN ROTARY ENGINES.

Specification forming part of Letters Patent No. 187,211, dated February 6, 1877; application filed September 20, 1876.

To all whom it may concern:

Be it known that I, HERMON G. WOOD, of Sharon, in the county of Mercer and State of Pennsylvania, have invented certain new and useful Improvements in Rotary Engines; and I do hereby declare that the following is a full, clear, and exact description thereof, which will enable others skilled in the art to which it appertains to make and use the same, reference being had to the accompanying drawings, and to letters of reference marked thereon, which form a part of this specification.

My invention relates to rotary engines; and the invention consists in certain new and improved devices and combinations of devices whereby the friction of the operating parts is greatly reduced, and the operation of such engines is rendered more perfect in every respect, all as hereinafter more fully set forth.

In the accompanying drawings, Figure 1 is a longitudinal sectional view of my improved engine. Fig. 2 is a transverse sectional view of the same taken on the line *x x*, Fig. 1. Fig. 3 is a sectional view of the valves taken on the line *z z*, Fig. 2. Fig. 4 is a transverse sectional view of the valves taken on the line *u u*, Fig. 3. Fig. 5 is a plan view of the abutment. Fig. 6 shows vertical and transverse sectional views of the guide, taken on the line 4' 4' of Fig. 2. Fig. 7 is an elevation or end view of the abutment, shaft, drum, and packing-pieces, which come in contact with the cylinder-head. Fig. 8 is a transverse sectional view of Fig. 5. Fig. 9 is a vertical sectional view, showing the apparatus for operating the valves and reversing the engine. Fig. 10 is an end view on side elevation of same.

Referring to the parts by letters, A represents the cylinder, having heads B-B, the cylinder and heads being secured together in any convenient and suitable manner.

The upper portion A' of the cylinder carries a valve-chest, and is provided with steam passage-ways and guideways for the oscillating steam-abutment, as hereinafter more fully set forth.

I prefer to have these portions of the engine cast in one piece with the cylinder A, and so that the heads B will fit both portions A and A'; but the portion A' may be made separate

from the cylinder A, and united thereto in any suitable and convenient manner, if so desired.

C is the shaft, its central portion D being made in the form of a crank and its ends tapering toward its outer extremities, as clearly shown by Fig. 1 of the drawings. E is the journal-box surrounding the central or crank portion of the shaft, said box being made in two halves and securely united by the key F. G is the abutment, consisting of a rectangular plate of metal united to a sleeve or ring, G', which fits the outer periphery of the box E. H H represent shoes for the abutment G, their under surfaces being arc-shaped, and their upper surfaces grooved longitudinally so as to fit the under side or edge of the abutment. I I represent arc-shaped plates or packing-pieces, which fit correspondingly-shaped recesses formed in the upper portion of the cylinder A, and between which the abutment G reciprocates, said plates thereby forming a guide for the abutment, which permits of its oscillation as well as of its reciprocation, as hereinafter set forth.

Recesses J are formed on the inner sides of these half-boxes I, having communication with cylinder A for the passage of steam to fill said recesses, and thereby counterbalance the pressure of the steam upon the abutment. The outer faces of the boxes are also provided with packing K, as clearly shown in Fig. 2 of the drawings. The outer edges of the abutment are also provided with packing L, which is held against the heads B by means of springs *t*, placed in recesses formed in the abutment, as clearly shown by Fig. 1 of the drawings. The upper portion of the faces of the abutment may also be recessed, and cut with holes or passages for holding lubricating material, as shown by dotted lines in said figure, the lubricating material being introduced through an oil-cup, W, on the top of the portion of the cylinder A'.

Springs similar to the springs *t* may also be employed for the purpose of holding down the shoes H.

M M are drums, keyed eccentrically to the shaft C by keys N, as clearly shown in Fig. 7 of the drawings. The ends or outer faces of these drums are provided with packing-rings

O and packing P, held out by springs U on the outer periphery of the drums, so as to cause them to work steam-tight, in close contact with the cylinder A and heads B.

Q Q are springs, secured at one end to the abutment-sleeve G', for the purpose hereinafter set forth. R R represent boxes for the shaft C, said boxes being secured to the heads B in any suitable and convenient manner. S S represent the steam-passages communicating with the interior of the cylinder A by means of the ports *g g*. V is the valve, the stem of which is provided with a crank, *b*, on the outside of the head B, and with a crank-pin, *c*, which passes eccentrically through a hole in a disk, *d*, which eccentric disk is provided with a lever or handle, *f*, and *a* is an eccentric rod or strap, the upper portion of which passes around the eccentric disk *d*, and the lower around a loose eccentric pulley, *l*, whose motion is limited by stops or lugs *e* secured to the flange of the driving-pulley *p*. *g* represents the cylinder-ports; *h*, the valve-port; *i*, the steam-induction pipe; and *j* the eduction-pipe. *k* represents the pulley which drives the governor; *l*, the eccentric pulley to work the valve V; *m*, pins or bolts to hold the boxes R in position; *n*, screws or bolts to hold the driving-pulleys *p p* in position. *q* represents the packing for the valve V; *s*, opening in pulleys to allow of the adjustment of the boxes R.

The operation of the engine is as follows: Steam being admitted to the interior of the cylinder through the valve V, as shown by the arrows in Fig. 2 of the drawings, will act upon the abutment G and drums M, causing the latter to revolve in close contact with the interior of the cylinder, and said drums being keyed to the shaft C, will, of course, cause the latter to revolve. The guide-boxes I I, being semicircular, oscillate in their seat, and thereby permit of the abutment having an oscillating as well as a reciprocating motion, as it passes up and down between the guides I. The recesses J, on the inner faces of the guides I, being filled with steam, exercise a counter-pressure upon the abutment, thereby greatly reducing the friction between the abutment and the guides. The springs Q on the outer periphery of the circular part G' of the abutment, are arranged so as to first come in contact with the cylinder or upper portion thereof, as the abutment traverses or moves from one side of the cylinder to the other, thereby breaking the shock of contact and avoiding noise and unnecessary friction between the abutment and that part of the cylinder.

Only two of these springs Q are shown in the drawings; but any number may be used as found most convenient, and they may be of any desired length.

The openings or ports into the interior of the cylinder are of greater width at the middle of the cylinder than at the side, as clearly shown by Fig. 5 of the drawings, and the

shoes or packing-pieces H are of corresponding shape—*i. e.*, wide toward the middle of the cylinder, and narrowing toward the extremities.

This arrangement allows the packing P in the outer periphery of the drums to pass the abutment smoothly and without noise, and with greatly-decreased friction.

The crank portion D of the shaft C is made slightly tapering, and the sectional box E of corresponding form on its inner periphery, and the key F, which is inserted between the sections of the box E, is also made tapering in form.

This construction and arrangement of the crank, box, and key, provide a convenient means of adjustment to compensate for the wear of the parts.

It will also be seen that the shaft C is provided with conical or tapering journals and boxes, for convenience of adjustment.

To-adjust the boxes R, the pins *m* are first removed, when the boxes may be screwed or moved farther in, and the pins replaced.

The valve V is operated by an eccentric, *l*, receiving movement from the shaft.

The devices for varying the speed of the engine, and for stopping or reversing it, are as follows:

The disk or crank *b* being secured to the valve-stem and provided with the crank-pin *c*, and the latter passed eccentrically through the disk *d*, which is provided with a lever, *f*, and connected or passed through the head of the eccentric rod *a*, it will be obvious that, by changing the position of the lever *f*, the valve-*g* will be turned in its seat, thereby partially or entirely cutting off the steam or turning the valve so as to cause the steam to pass into the cylinder through the port on the opposite side of the abutment, and thereby reverse the motion of the shaft.

I have shown my improvements as applied to a single-cylinder engine; but it will be obvious to those skilled in the art that two or more cylinders may be used and arranged so as to operate upon the same shaft.

It will also be obvious to those skilled in the art, that, by the use of my improvements, I secure all the advantages resulting from the use of a crank-shaft—a result which, so far as I have been able to discover, has not before been accomplished in rotary engines.

Having thus described my invention, what I claim as new, and desire to secure by Letters Patent, is—

1. The crank-shaft C D, operating in combination with the divided box E, and the oscillating and reciprocating abutment G, substantially as and for the purpose specified.

2. The combination of the crank-shaft C D, divided box E, abutment G, and oscillating guides or boxes I, substantially as and for the purpose specified.

3. The guides or boxes I, having recesses J operating in combination with the reciprocating

cating and oscillating abutment G, substantially as and for the purpose specified.

4. The abutment G, having the circular portion G', in combination with the shoes H, constructed as described, and operating so as to form a tight packing or joint between the abutment and drums M, substantially as specified.

5. The combination of the oscillating and reciprocating abutment G, box E, and shaft C, with the shoes H and drums M, substantially as and for the purpose specified.

6. The conical crank-shaft D and boxing E, made tapering, as described, in combination with the tapering key F and abutment G, substantially as and for the purpose specified.

7. The abutment G, having its circular por-

tion G' provided with springs Q arranged to operate in combination with the cylinder A, substantially as and for the purpose specified.

8. The combination of the loose eccentric pulley *l* and stops or lugs *e*, with the eccentric strap *a*, disk *d*, and crank *b*, for the purpose of operating the valve V, to reverse the engine, substantially as and for the purpose specified.

In testimony that I claim the foregoing as my own, I affix my signature in presence of two witnesses.

HERMON GAYLORD WOOD.

Witnesses:

W. W. MASON,
NELSON P. BRYDEN.