

E. A. DANA.
WIND-MILL.

No. 187,256.

Patented Feb. 13, 1877.

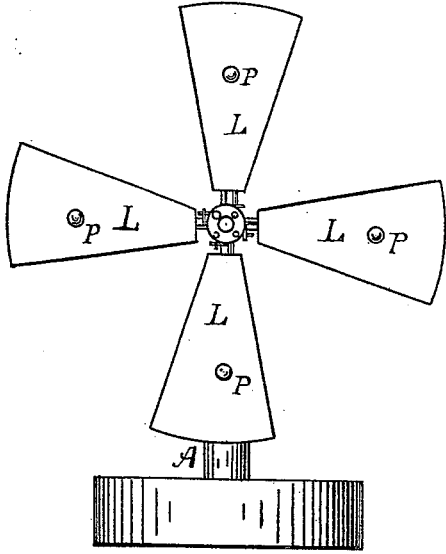

Fig. 1.

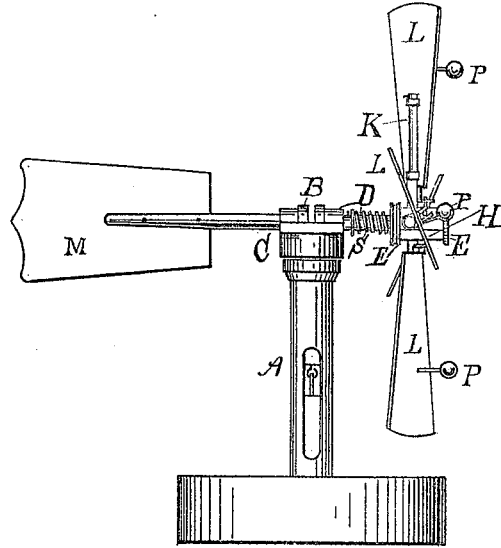

Fig. 2.

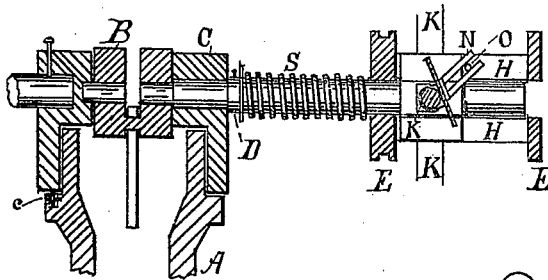

Fig. 3.

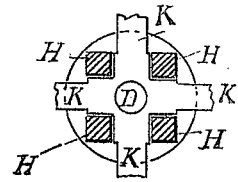

Fig. 4.

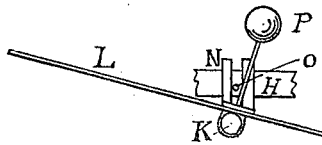

Fig. 5.

WITNESSES

T. Evans
Frank C. Parker

INVENTOR

Edward A. Dana
per William Edson atty

UNITED STATES PATENT OFFICE

EDWARD A. DANA, OF BOSTON, MASSACHUSETTS.

IMPROVEMENT IN WINDMILLS.

Specification forming part of Letters Patent No. 187,256, dated February 13, 1877; application filed November 18, 1875.

To all whom it may concern:

Be it known that I, EDWARD A. DANA, of Boston, in the county of Suffolk and State of Massachusetts, have invented an Improvement in Windmills, of which the following is a specification:

My invention relates to that class of windmills in which the sails are radial, and are pivoted on radial arms, so that they are reefed by swinging them on the radial arms as axes, and consists in connecting all of the sails to a single reefing-trundle, each sail being provided with a weighted projection, which is acted upon by the force due to the centrifugal motion; also, in forming each sail with an overhang, and in the particular construction of the parts.

Figure 1 is a front elevation of my windmill. Fig. 2 is a side elevation of the same. Fig. 3 is a section through the pedestal-head, also showing the shaft and trundle, and some details. Fig. 4 is a cross-section through the trundle, shaft, and arm-connections. Fig. 5 shows in detail one of the sails, the weighted projection, and the device by which the reefing action is made uniform on all of the sails.

My windmill may be mounted upon any desirable pedestal—A, for instance. C is a revolving housing placed on the top of the pedestal, which is provided with friction-rollers, one of which is shown at *c*, Fig. 3. The housing C holds the main shaft D of the windmill, and also the crank B. (See Figs. 2 and 3.) To the shaft D I affix the cross-arms K K K K, Figs. 2, 3, and 4. To each of the cross-arms K I hang the sails L in such a manner that each is free to swing on the arm as an axis. E E H H is a trundle loosely placed on the shaft D, (see Figs. 2, 3, and 4,) and held up toward the wind by the spring S. The four wings H H H H of the trundle are made square, as shown in Figs. 3 and 4. Each wing has a pin, O, (see Figs. 3 and 4,) which is embraced by a forked piece, N, extending from the sail, Figs. 3 and 5. This forked piece or arm N attached to each sail causes all of them to reef alike—that is, if one turns it must cause the trundle E H E to move on the shaft D. This action, operating through the pins O and respective arms N, will cause a uniform motion of all of the sails, the

spring S having a tendency to throw the trundle forward and the sails up to the wind.

Each sail is provided with a weighted projection, P, (see Figs. 1, 2, and 5,) so placed that when the sail is well up to the wind, as it will stand in a calm, owing to the pressure of the spring S the weight will be nearly in the plane of the axis of the shaft—that is, at nearly its least distance from the axle. Therefore, when the wheel revolves, the centrifugal tendency of the weights P P will be to move out of the plane of the axle, so as to get farther away from it. This action will throw the sail out of the wind, or, in other words, reef it.

The object of placing the weights P a little out of the plane of the axis, in the direction in which it is desired to have it move, is to insure its moving in said direction when acted upon by the centrifugal force. The sails L are each made with an overhang, as shown in Fig. 5, the part *l'* extending farther from the arm K than the part *l*, thus forming the overhang. The tendency of the overhang when the sails are revolving is to bring them into the plane of motion, or up to the wind, and is in opposition to the tendency of the weighted projections P.

As the action due to the tendency of the overhang to come into the plane of motion is balanced by the action of the weights P, it may be seen that the direct force of an excessive wind on the overhang is free to act, and thus throw the sails out of the wind, or reef them.

Having now described the construction and operation of my invention, what I claim is as follows:

1. The combination of the sail L swinging on the arm K, with the weighted projections P affixed to the sail L, and the spring S acting through the fork N to steady and regulate the action of the weighted projection P, substantially as described, and for the purpose set forth.

2. The combination of the sails L, the arms N, and pins O, with the trundle E H E, shaft D, and spring S, all operating together substantially as described, and for the purpose set forth.

EDWARD A. DANA.

Witnesses:

WILLIAM EDSON,
NATHANIEL EVANS, Jr.