

L. PRAHAR.  
DOUBLE-ACTING PRESSES.

No. 187,311.

Patented Feb. 13, 1877.

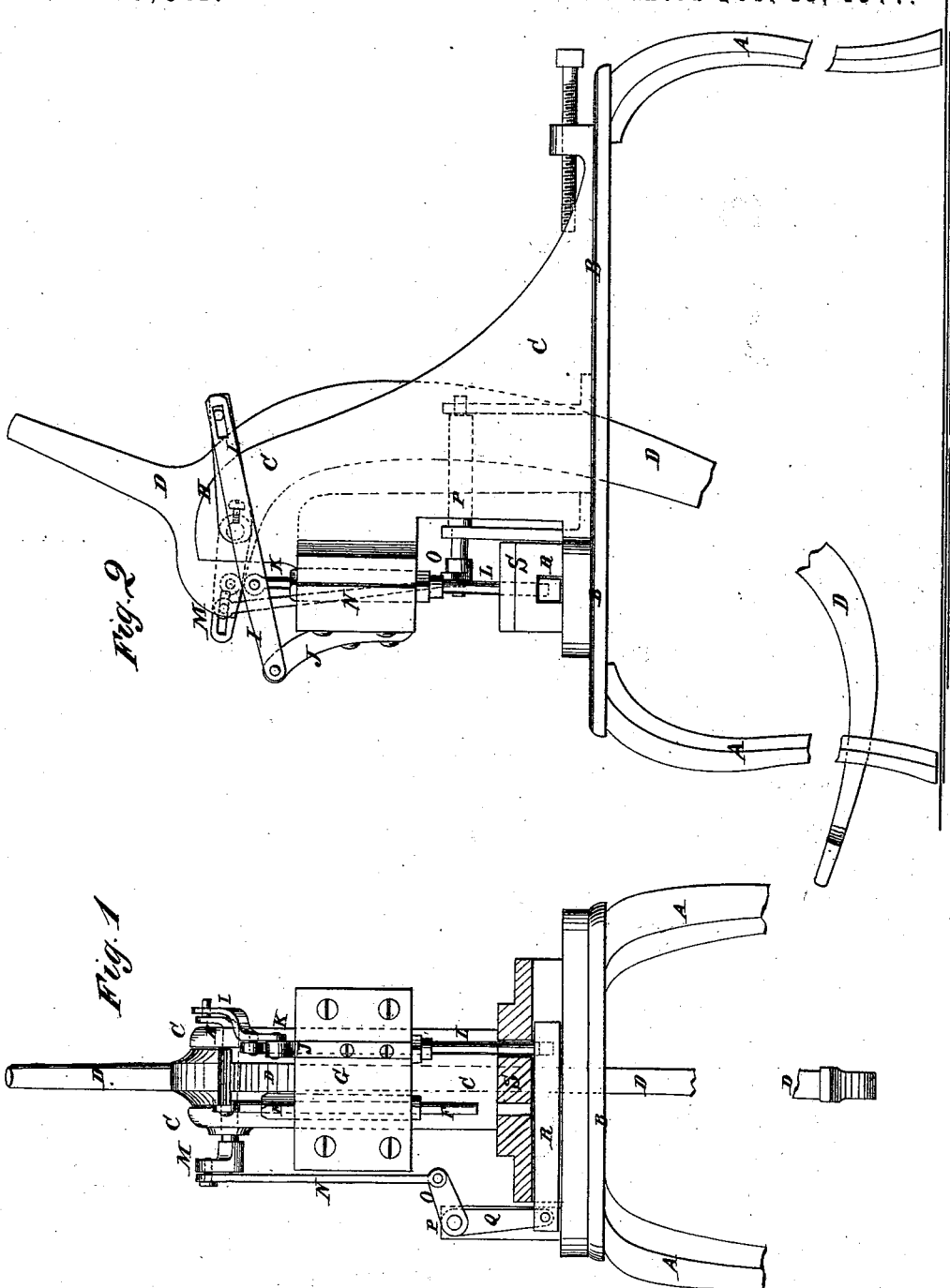

WITNESSES:  
*H. W. Monquist*  
*John Coethals.*

INVENTOR:  
*L. Prahar.*  
BY *Mumford*

ATTORNEYS.

# UNITED STATES PATENT OFFICE.

LOUIS PRAHAR, OF NEW YORK, N. Y.

## IMPROVEMENT IN DOUBLE-ACTING PRESSES.

Specification forming part of Letters Patent No. 187,311, dated February 13, 1877; application filed September 16, 1876.

### *To all whom it may concern:*

Be it known that I, LOUIS PRAHAR, of the city, county, and State of New York, have invented a new and useful Improvement in Double-Acting Foot-Motion Presses, of which the following is a specification:

Figure 1 is a front view of my improved press, part being broken away to show the construction. Fig. 2 is a side view of the same.

Similar letters of reference indicate corresponding parts.

The object of this invention is to furnish an improved foot-motion press which shall be so constructed as to cut out a blank with the rearward motion of the foot-lever, and, by the forward motion of said foot-lever, carry the said blank to a die and press it to the desired form, and which shall be simple in construction and convenient in use.

The invention consists in the combination of the crank-arm and the connecting-rod with the foot-lever, and with the holder for the second die or cutter; and in the combination of the sliding-bar, the two cranks, and the connecting-rod, whether the upper crank be used or not, with the foot-lever and with the die-block, as hereinafter fully described.

A are the legs, B the bed-plate, C the standard, and D is the foot-lever, of an ordinary press.

To the forward upper part of the lever D is pivoted the holder E, for the cutter or die F, which holder works in a guide-hole in the block G, bolted to the forward side of the upper part of the standard C. To one end of the pivot of the foot-lever D is rigidly attached a crank-arm, H, the crank-pin of which works in a short slot in the rear end of the connecting-bar I, the other end of which is pivoted to a bracket, J, attached to the guide-block G. To the connecting-bar I is pivoted the upper end of the holder K, which works in a guide-hole in the block G, and to the lower end of which is attached the cutter or die L. To the other end of the pivot of the foot-lever D is rigidly attached a crank-arm, M, to the crank-pin of which is pivoted the upper end of the connecting-bar N, the lower end of which is pivoted to the pin of the crank O, which is rigidly attached to the shaft P, which works in bearings attached to the bed-plate B. To the shaft P, or to the

crank O, is rigidly attached a crank-arm, Q, which is pivoted to the end of the bar R, which works in a hole in or beneath the die-block S, attached to the forward part of the bed B.

With this construction, as the lever D is pressed back by the foot, the die F descends and cuts a blank out of the material fed upon the block S, the blank passing down through a hole in the block S, and dropping down upon a die in the bar R. As the foot-lever D swings forward, the die F is raised, the die L is forced down, and the bar R is pushed forward, bringing its die and the blank upon it directly beneath the descending die L, so that the said blank may be pressed into the desired form. As the die L again rises the completed article drops out, or is thrown out by any of the well-known devices for such purposes.

As the crank-arm M is rigidly connected with the lever D, it may be omitted, and the upper end of the connecting-rod N pivoted directly to the said lever D.

By giving a greater curve to the rear part of the lever D, the crank-arm H and the connecting-rod I may be omitted, and the holder K pivoted to the lever D in the rear of its pivot, so that the dies F L may always move in the opposite direction. This arrangement would bring the dies F L in line with the length of the machine, and would render it unnecessary for the device M N O P to be so arranged as to move the bar R in the same direction.

Having thus described my invention, I claim as new and desire to secure by Letters Patent—

1. The combination of the crank-arm H and the connecting-rod I with the lever D, and with the holder K, for the die or cutter L, substantially as herein shown and described.
2. The combination of the sliding bar R, the two cranks Q O, and the connecting-rod N, whether the crank M be used or not, with the foot-lever D, and with the die-block S, substantially as herein shown and described.

LOUIS PRAHAR.

Witnesses:

JAMES T. GRAHAM,  
ALEX. F. ROBERTS.