

B. VANDECAR & H. V. HARPER.

STEAM-TRAP AND BOILER-FEEDER.

No. 187,331.

Patented Feb. 13, 1877.

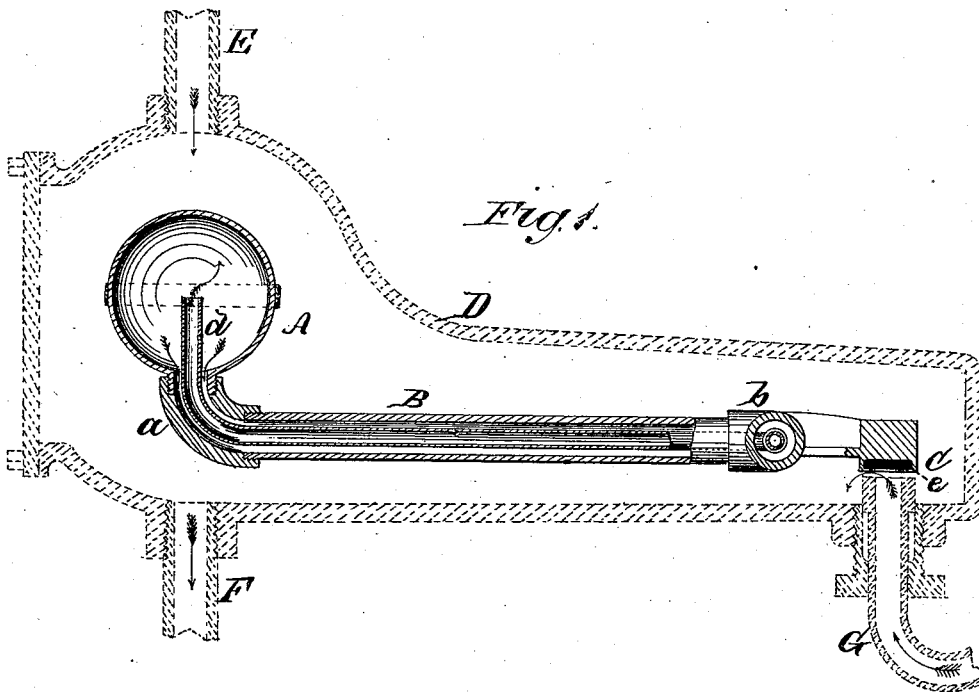
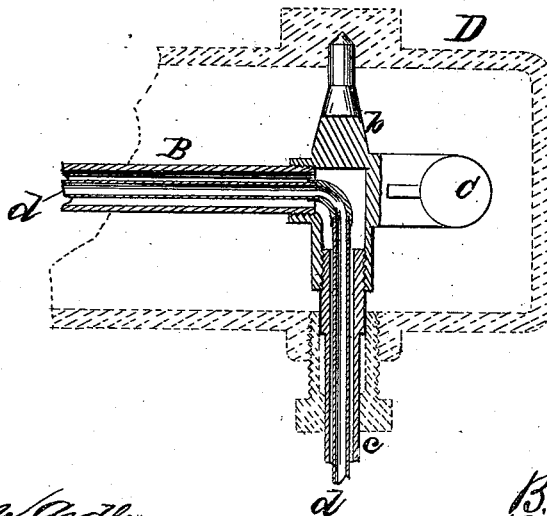

FIG. 2.



WITNESSES:

*Francis M. Castle,*  
*Alex. J. Roberts.*

INVENTORS.

*B. Vandecar,*  
*H. V. Harper,*  
BY *[Signature]*  
ATTORNEYS.

# UNITED STATES PATENT OFFICE.

BENNETT VANDECAR, OF CANAJOHARIE, AND HENRY V. HARPER, OF  
ALBANY, NEW YORK.

## IMPROVEMENT IN STEAM-TRAPS AND BOILER-FEEDERS.

Specification forming part of Letters Patent No. **187,331**, dated February 13, 1877; application filed  
January 19, 1877.

*To all whom it may concern :*

Be it known that we, BENNETT VANDECAR, of Canajoharie, in the county of Montgomery and State of New York, and HENRY V. HARPER, of Albany, in the county of Albany and State of New York, have invented a new and Improved Float, of which the following is a specification :

Figure 1 is a side elevation, in section. Fig. 2 is a top view, in section.

Similar letters of reference indicate corresponding parts.

Our invention relates to floats to be used for controlling the supply of water to a tank or boiler; and it consists of a float-ball having a tubular lever or arm provided with an outside connection for the escape of water that may sweat or condense in the ball. It also consists in a vent-tube running through the tubular lever for the admission of air to the float ball, and also in an improved valve attached to the float-lever for closing the inlet-pipe of the tank or boiler.

Referring to the drawing, A is a float-ball, to the lower side of which the tubular lever B is connected by an elbow, *a*. The lever B is screwed into a casting, *b*, which forms the journals upon which the said lever turns, the journals having bearings in the casing or tank in which the float moves, and one of them, *c*, is hollow and extends through the case or tank, and is provided with a stuffing-box to prevent the escape of water around it. A vent-tube, *d*, runs through the hollow journal *c*, and through the tubular lever B, and projects upward into the float-ball A. By this arrangement air is admitted to the interior of the ball through the tube *d*, and permits water that may "sweat or condense through" into the ball to escape through the tubular lever B and the hollow journal *c*, through the space between the outer surface of the tube *d* and the inner surface of the tubular lever B and hollow journal *c*. C is an arm projecting from the side of the casting *b*, opposite the tubular

lever B, which is recessed to receive an elastic disk or valve, *e*, which is brought into contact with the end of a supply-pipe by the action of the float.

The float herein described is applicable to water-tanks and to boilers. When applied to boilers it is placed in a casing, D, indicated by dotted lines in the drawing, which casing is placed centrally on the water-line of the boiler and connected by pipes E and F with the upper and lower parts of the boiler, so that the level of the water in the casing D and in the boiler will be the same. G is a feed-pipe for the boiler, which projects into the casing D immediately under the disk *e* carried by the arm C, so that an increase in the quantity of water in the boiler raises the float A, thereby depressing the arm C, and bringing the elastic disk *e* into contact with the mouth of the pipe G, and shutting off the water-supply. When the water-level falls the float drops and the supply-pipe is opened.

The advantage gained by our improvement is that, in case of sweating or condensing in the float-ball, the water escapes through tubular lever, obviating "water-logging," so that a positive action is secured.

Having thus described our invention, we claim as new and desire to secure by Letters Patent—

1. The combination of the float-ball A, tubular lever B, vent-tube *d*, and casting *b*, having the hollow journal *c*, substantially as herein shown and described.

2. The arm C, and elastic disk *e*, in combination with the casting *b*, lever B, and float A, substantially as shown and described.

BENNETT VANDECAR.  
HENRY V. HARPER.

Witnesses for B. VANDECAR:

STAFFORD MOSHER,  
C. E. DIEFENDORF.

Witnesses for H. V. HARPER:

FRANK KAMPFER,  
THOS. B. MORROW.