

H. R. MARSDEN, dec'd.
A. POLLOK, Adm'r.

STONE AND ORE CRUSHER.

No. 187,414.

Patented Feb. 13, 1877.

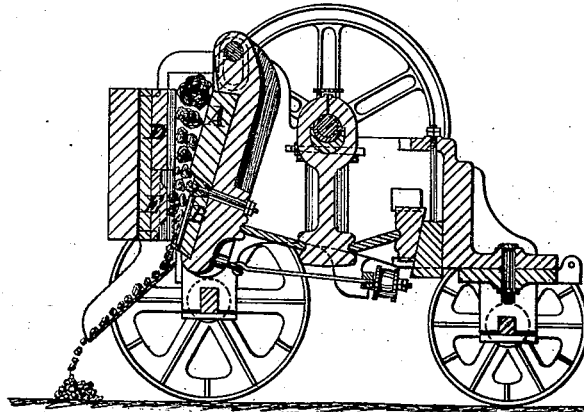

FIG. 1

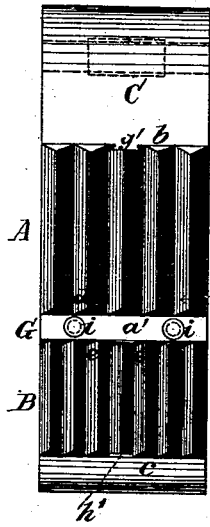

FIG. 3

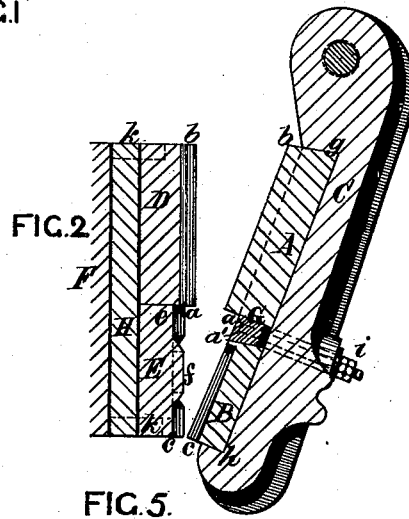

FIG. 2

FIG. 5.

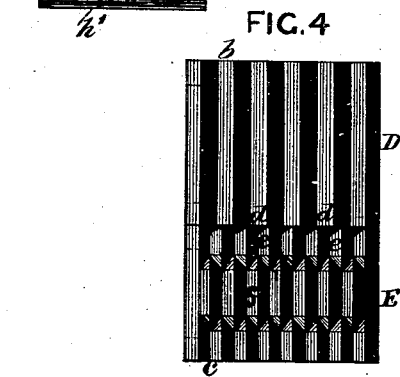

FIG. 4

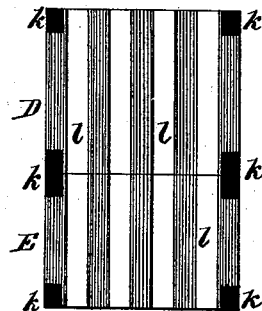

FIG. 6.



*Ewell & Sick
W. J. Hutchinson.*

*A. Pollok
Administrator of the Estate
of Henry Rowland Marsden
deceased.*

UNITED STATES PATENT OFFICE.

ANTHONY POLLOK, OF WASHINGTON, DISTRICT OF COLUMBIA, ADMINISTRATOR OF HENRY ROWLAND MARSDEN, DECEASED, ASSIGNOR TO GEORGE DALTON, OF LEEDS, ENGLAND.

IMPROVEMENT IN STONE AND ORE CRUSHERS.

Specification forming part of Letters Patent No. 187,414, dated February 13, 1877; application filed September 12, 1876.

To all whom it may concern:

Be it known that HENRY ROWLAND MARSDEN, late of Leeds, in the county of York, England, deceased, did in his life-time invent certain Improvements in Stone and Ore Crushers, of which the following is a specification:

This invention relates to that description of apparatus in which the stones or other hard and brittle substances to be broken or reduced are operated upon between a stationary jaw and a movable jaw, or between two movable jaws, and which apparatus are generally known as "Blake's stone-breaking machines;" and it has for its chief object reducing the stones, for example, to a form approximating more nearly to that of a perfect cube than is attainable with the apparatus as heretofore constructed; a further object of the invention is to facilitate the fitting of the jaws, and to dispense with the white-metal joint ordinarily required.

In carrying out the invention, in order to obtain these objects, the apparatus is constructed and arranged in the following manner, reference being had to the several figures on the accompanying drawings, which represent a machine consisting of a stationary jaw and a movable jaw.

The same letters indicate like parts in all the figures.

Figure 1 of the accompanying drawing represents a sectional elevation of a complete machine having the improvements which form the subject of this invention applied thereto. Fig. 2 represents a section taken through the two jaws. Fig. 3 represents a front elevation of the movable jaw; and Figs. 4, 5, and 6 represent, respectively, front and back elevations and sectional plan of the stationary jaw.

A B is the removable working-face of the movable jaw, and C is the jaw-stock. D E is the removable working-face of the stationary jaw, and F is the portion of the frame into which it is fitted.

According to one part of the invention, in lieu of making the longitudinal line of the teeth straight or a continuous contour from

the top of the jaw to the bottom thereof, an abrupt recession is made in the plane of the teeth, as shown at *a a*, Fig. 2, so that the longitudinal line of the portion of the toothed surface which is above the point *a*—viz, from *a* to *b*—projects to some extent beyond the longitudinal line of the portion of the toothed surface which is below the point *a*—videlicet, from *a* to *c*.

By means of this arrangement, the stone under operation, after it has been first broken by the upper portions *a b*, on reaching the top of the lower portion *a c*, is caused to roll or turn over by reason of the sudden change or recession in the plane of the face of the teeth, whereby the stones are reduced to an approximately perfect cuboidal form, in lieu of to a semi-elongated form, as is frequently the case when operated upon in the apparatus as previously constructed.

In the drawings, both the stationary jaw and the movable jaw are shown as constructed with the recession *a*; but either of them may be made straight, or of a continuous contour from the top *b* to the bottom *c*, the other only being formed with the recession *a*.

The lines of the points of the teeth and of the intervening furrows are continued straight from the top *b* as far as the point *a*, only below which point the teeth are diverted laterally—that is to say, the points *d d* of the upper portion, Figs. 3 and 4, do not coincide with the points *e e* of the lower portion, this arrangement, in conjunction with the recession at *a*, tending greatly to facilitate the operation of cubing.

The teeth of the lower portion, although diverted, may be constructed of the same pitch as those of the upper portion; but it is preferred to construct them of smaller pitch, as shown in the drawing.

The mode of arranging the teeth of the lower portion of the opposite jaws may be varied; but the arrangement in the example illustrated has been found convenient and efficient in practice.

In this example, the teeth of the lower portion of the movable jaw are continued uniform

from the point *a* to the bottom *c*, with the exception that a transverse flat surface is provided at *a'*, while those of the lower portion of the stationary jaw are similar at the parts *e* and *c*, but their points and furrows are again diverted at the intermediate portion *f*. In the upper portions, moreover, the points of the teeth of one jaw are arranged opposite the furrows of the other jaw, while at the extremity of the lower portions the points of the teeth of one jaw are arranged opposite the points of the teeth of the other jaw.

The working-faces of the jaws are made renewable, and they may also be made reversible from top to bottom, and from back to front, so as to obtain four successive wearing-surfaces.

In the example shown in the drawings the removable working-faces are made reversible from top to bottom only, in the following manner: The working-faces are constructed in two main parts, as shown, *A B* being those of the movable, and *D E* those of the stationary jaw, the upper parts *A* and *D*, respectively, of which terminate at their lower ends at the point of recession of the plane of the face of the teeth, so that each part of either jaw may be reversed separately. The lips *g h* of the jaw-stock *C* are slightly undercut, and a wedge-piece, *G*, is employed for securing the two parts *A B* in position; by the act of tightening which wedge-piece, by the aid of bolts and nuts *i i* the two parts are forced outward into, and maintained in, their place, a tongue and recess at *g' h'*, Fig. 3, serving to prevent any lateral movement.

In fitting the working-face *A B* to the jaw-stock *C*, if the usual white-metal joint is not employed, it is requisite that the front surface of the jaw-stock and the back surface of the working-face *A B* should be planed true and smooth; but as it is also indispensable that the working-face be made of a very hard material, it has hitherto been found impracticable to dispense with the joint of white metal.

According to this invention the required object is effected in the following manner: A metal plate or mold is first prepared to the shape of the counterpart of the jaw-face to be produced, and white iron (that is to say the hardest mixture of metal practicable) in a molten condition is then poured into a sufficient height to form the toothed portion of the face, after which the mold is filled with hematite or other suitable iron in one continuous operation.

By these means the requisite hard resisting-surface is obtained at the toothed portion of the face, whilst the back is sufficiently soft to admit of its being planed.

The working-face *D E* of the stationary jaw may also be fitted to the frame *F* in a similar manner, when practicable; but it is preferred to employ the arrangement shown in the drawing. In this case the parts *D E*, which are

cast of hard metal, have wrought-iron or other suitable soft metal bars or strips *l l* cast at their back by placing the bars in a mold and pouring in the metal around them, so as to form a surface sufficiently soft to be capable of being planed. And as it is requisite that the abutting surface of the frame should also be true and smooth, and it is found to be inconvenient to plane the front surface of the frame itself, a soft intervening cast-iron plate *H* is employed, which is planed to adapt it to the bars *l l*, and then inserted in the frame *F*, and retained by lips or projections, the parts *D E* being maintained in position by means of projections and recesses at *k*, with which the plate *H* and the parts *D E* are respectively provided, after which the whole is secured by wedges in the usual manner. If desired, the working-face *A B* of the movable jaw may be provided with wrought-iron bars or strips in lieu of its being cast of metal of different degrees of hardness, as hereinbefore described.

Both methods of constructing the surfaces of the working-faces are also applicable to breaking and reducing surfaces generally where a similar object is desired to be attained.

I claim as the invention secured to me for improvements in machinery or apparatus for breaking or reducing stones and other hard and brittle substances—

1. A jaw whose toothed face is constructed substantially as set forth, so that the plane of the face of the upper portion of the length of such surface projects beyond the plane of the face of the lower portion of the length of such surface, and that the lines of the points and furrows of the teeth of the lower portion are diverted laterally from the lines of the points and furrows of the teeth of the upper portion, substantially as and for the purposes hereinbefore described.

2. A jaw in which the upper and lower portions of the toothed surface have their teeth of a different height and indifferent vertical planes both in the transverse line of the face of the teeth and at right angles thereto, substantially as and for the purposes hereinbefore described.

3. The renewable working-faces of jaws, in which the teeth of the upper and lower portions are in different planes constructed in two or more parts, and fitted and secured to the jaw stock or frame in such a manner as to enable them to be reversed or renewed separately when worn, substantially as hereinbefore described.

4. The acting-faces or portions of the crushing-jaws, made substantially as herein set forth—that is to say, adapted to be removably fitted to, or contained within, a stock or frame, and constructed with their front and back faces cast of metal of different degrees of hardness, as and for the purposes hereinbefore described.

5. A jaw having a recession, substantially as herein shown and described, affording a space for the stone or stones, after having been broken by the upper portion of the toothed surfaces, to be turned and rolled over before being operated upon by the lower portion of the toothed surfaces, as hereinbefore described.

In testimony whereof I have hereunto signed

my name this 12th day of September, A. D. 1876.

A. POLLOK,
Administrator of the estate of Henry Rowland Marsden, deceased.

Witnesses:

HENRY R. ELLIOTT,
EWELL A. DICK.