

J. G. WATSON.  
WIND-MILL.

No. 187,435.

Patented Feb. 13, 1877.

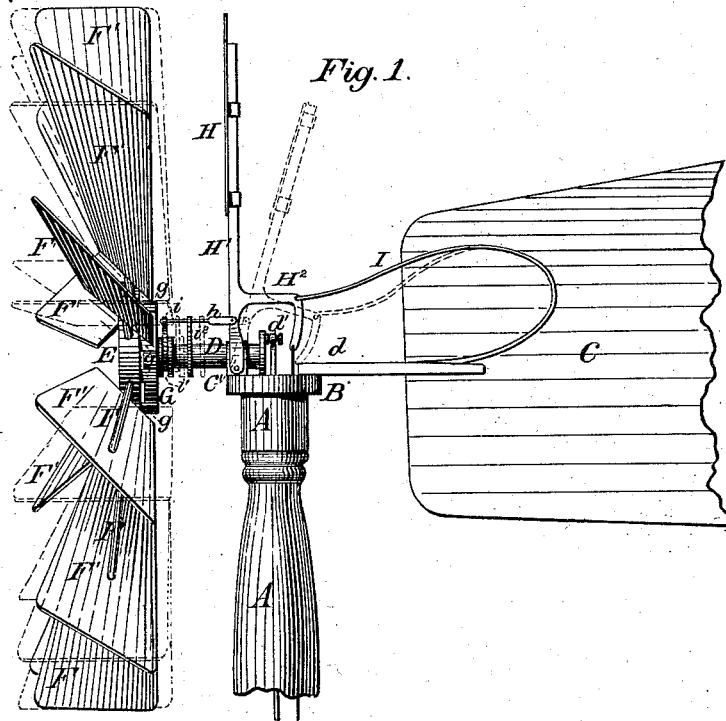
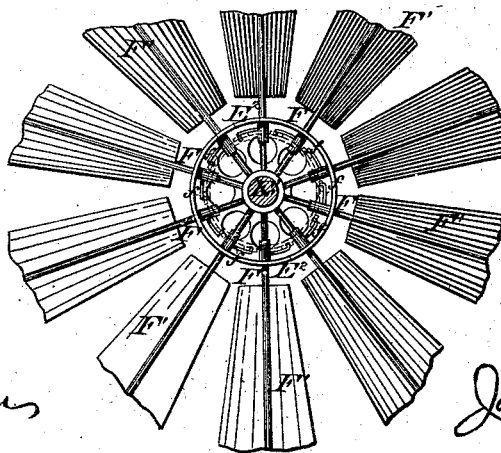

Fig. 3.



Attest:  
Charles Hurman  
W. Seely

Inventor:  
James Gillis Watson  
by Geo. W. Seely  
Attorney

J. G. WATSON.  
WIND-MILL.

No. 187,435.

Patented Feb. 13, 1877.

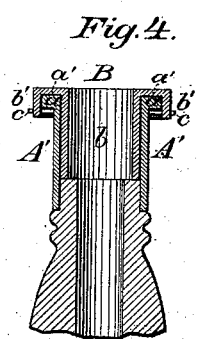
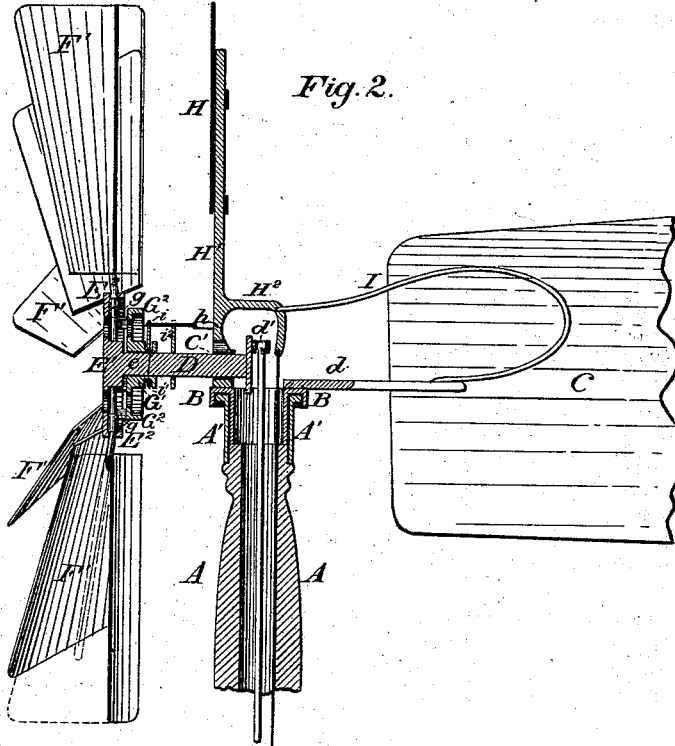

Attest:  
Charles Korman,  
L. W. Seely

Inventor:  
James Willis Watson  
by Geo. W. Dyer & Co  
Attorneys

# UNITED STATES PATENT OFFICE.

JAMES G. WATSON, OF SPRINGFIELD, ILLINOIS.

## IMPROVEMENT IN WINDMILLS.

Specification forming part of Letters Patent No. 187,435, dated February 13, 1877; application filed August 7, 1876.

### *To all whom it may concern :*

Be it known that I, JAMES GILLIS WATSON, of Springfield, in the county of Sangamon and State of Illinois, have invented a new and useful Improvement in Windmills; and I do hereby declare that the following is a full and exact description of the same, reference being had to the accompanying drawings and to the letters of reference marked thereon.

My invention relates to certain improvements in that class of windmills wherein the sails of the wind-wheel are turned axially in and out of the wind by the varying force of the same upon an upright fan; and the object of the invention is a simpler and more effective construction of the various parts.

My invention consists in the construction of the head of the windmill, carrying the sail-arms, in combination with the sails and arms; second, in the combination and construction of the parts for turning the sails in and out of the wind; and further, in the construction of the turn-table, all as more fully hereinafter explained.

To enable others skilled in the art to manufacture and use my mill, I now describe the same in connection with the drawings, in which—

Figure 1 is a side elevation of the windmill, showing in dotted lines the position of the parts when the upright fan is thrown back and the sails turned edge to the wind; Fig. 2, a central vertical section of the same; Fig. 3, an elevation from the inside of the head of the wind-wheel and a portion of the sails, the same being detached from the other parts of the mill, and Fig. 4, a cross-section of the turn-table and the upper part of the standard.

Like letters denote corresponding parts in each figure.

A represents the standard of the mill, of ordinary construction, upon which is mounted the turn-table B. The standard is capped by a cylindrical casting, A'. The top of this casting is provided with a flange, *a*, forming a flat annular bearing-surface. The turn-table B rests upon this bearing-surface, and has a central cylindrical casting, *b*, projecting downwardly from the under side of the turn-table into the casting A' and fitting closely the inside of the said casting A'. The outer edge of the turn-

table is provided with a downwardly-projecting flange, *b'*, which incloses the outer edge of the flange *a*, a plane bearing-surface, *a'*, being formed on the under side of the turn-table between the cylindrical casting *b* and the flange *b'*. This bearing-surface *a'* rests upon the flange *a*, a hole being bored in the turn-table through which the parts are lubricated. One or more studs, *c*, project from the inside of the flange *b'*, under the flange *a*, to further steady the turn-table. This turn-table is very simple in construction, and operates easily and without jarring. From the turn-table B an arm, *d*, projects to the rear, to which is rigidly attached the tail-fan C. To the front of the turn-table is secured the bearing-sleeve C'. Through this sleeve passes the shaft D of the wind-wheel, having on its inner end a crank, *d'*, which works in the center of the turn-table and operates through a pitman-rod, a pump, or other mechanism. On the front end of the shaft D is keyed the head E of the wind-wheel, to which are secured the arms F, carrying the sails F'. This head is composed of a hub, E<sup>1</sup>, and a rim E<sup>2</sup>. The rim is cast in one piece with the hub, and with a connecting part, *e*. The arms F pass through proper holes in the rim E<sup>2</sup>, inside of the part *e* of the head, and into sockets in the hub E<sup>1</sup>. Between the rim and the hub the arms F are provided with short cranks *f*, by which they are turned and the sails brought edge to the wind. By the construction of the head, having the hub and rim, the arms are held firmly in place and the strain divided between the hub and the rim. On the sleeve C' and extension *f'* of the hub E<sup>1</sup> is sleeved the sliding head G, smaller than the head E of the wind-wheel, having a hub, G<sup>1</sup>, and rim G<sup>2</sup>. To the rim G<sup>2</sup> of this head are rigidly secured short arms *g*, which connect with the cranks *f* on the sail-arms. H is an upright fan behind the wind-wheel. This fan is secured to an arm, H<sup>1</sup>, which has its lower end forked and pivoted to the sleeve C' at the front edge of the turn-table. The fan H is adjustably secured to its arm, and is adapted to be raised and lowered, to receive greater or less force from the wind. The higher the fan is raised the more force the wind exerts upon its arm, partly from the more surface exposed and partly from the greater leverage obtained.

Above the sleeve  $C'$  to the arm  $H^1$  is secured one end of a rod,  $h$ , which extends to a clutch,  $i$ , working in a groove,  $i'$ , in the hub  $G^1$  of the head  $G$ . This rod  $h$  is connected to a guiding-sleeve,  $i^2$ , sliding on the sleeve  $C'$  between the clutch,  $i$ , and the arm. The arm  $H^1$  is provided with an angular arm,  $H^2$ , projecting to the rear. The angle of this arm  $H^2$  is connected with an elliptical spring,  $I$ , which throws the arm  $H^1$  and fan  $H$  forward; but a weight suitably attached may be used instead. The end of the angular arm  $H^2$  is connected with a rod or chain which passes down through the standard of the mill, and, when pulled downwardly, throws the upright fan and its arm backward.

The operation of the mill is as follows:

By the action of the wind upon the tail-fan  $C$  the wind-wheel is brought around into the wind, and by its force the wheel is turned. But as the force of the wind increases, the upright fan will be moved backward and the sails turned more nearly into a line with the wind, the speed of the wheel being thereby regulated. Upon a further increase of the wind, the sails will be thrown edge to the wind and the mill stopped. The force of the wind lessening, the spring  $I$  restores the upright fan to its original position. When it is desired to stop the mill at any time, the upright fan and its arm are thrown back by the chain or rod secured to the arm  $H^2$ . The adjustability of the upright

fan admits of its being regulated to allow the wind-wheel to turn with any desired speed.

Having thus fully described my windmill and explained some of its advantages, what I claim as new therein, and desire to secure by Letters Patent, is—

1. In a windmill, the combination, with the sails  $F'$  and arms  $F$ , of the head  $E$ , composed of the hub  $E^1$ , rim  $E^2$ , and connecting part  $e$ , all constructed and arranged substantially as described and shown.

2. In a windmill, the combination, with the turn-table  $B$ , of the sleeve  $C'$ , the shaft  $D$ , the head  $E$ , consisting of the hub  $E^1$ , rim  $E^2$ , and connecting part  $e$ , the sails  $F'$ , arms  $F$ , head  $G$ , cranks  $f$ , arms  $g$  adjustable upright fan  $H$ , arm  $H^1$ , rod  $h$ , and tail-fan  $C$ , all constructed and arranged substantially as described and shown.

3. In a windmill, the combination, with the standard  $A$ , of the cylindrical casting  $A'$ , having the flange  $a$ , and the turn-table  $B$ , having the cylindrical casting  $b$ , flange  $b'$ , and studs  $c$ , all constructed and arranged substantially as described and shown.

This specification signed and witnessed this 19th day of April, 1876.

JAMES GILLIS WATSON.

Witnesses:

SAMUEL D. SHOLES,  
THOS. C. MATHER.