

C. B. WITHINGTON.  
GRAIN-BINDER.

No. 187,443.

Patented Feb. 13, 1877.

Fig. 1.

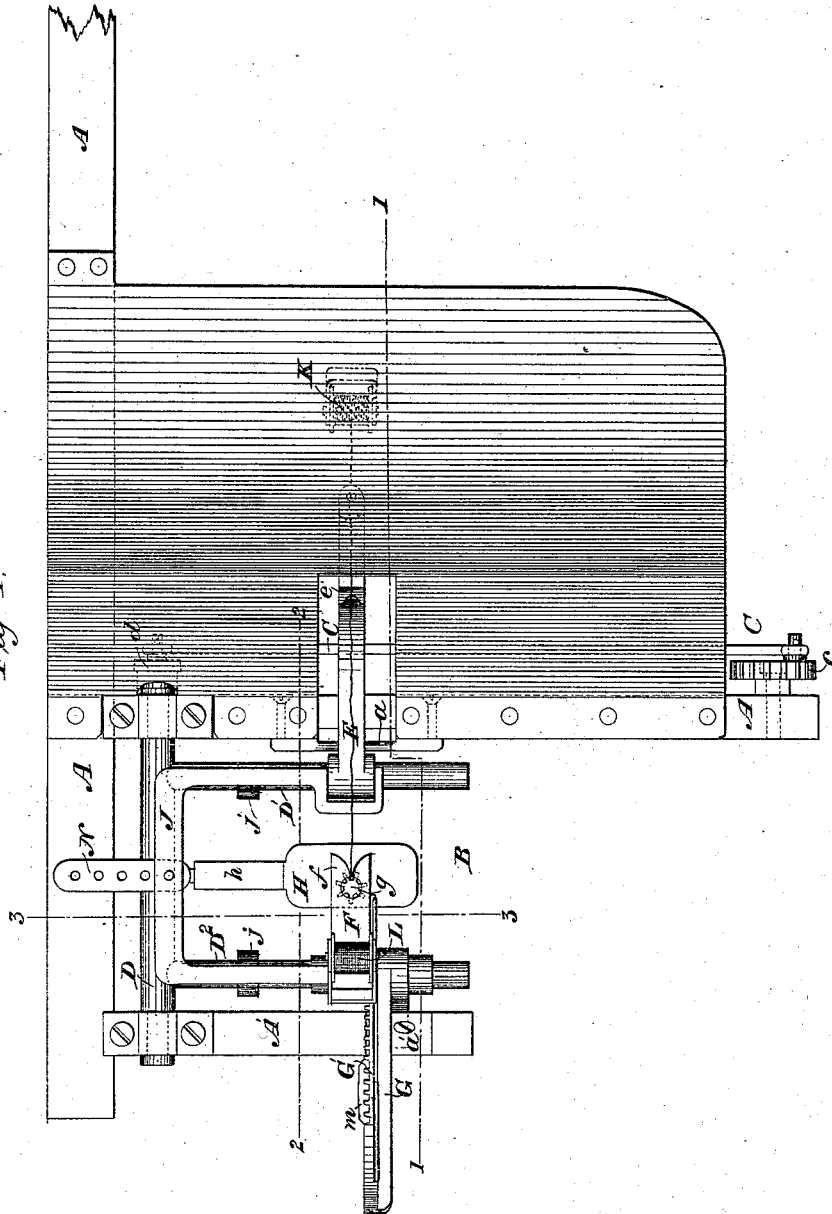

WITNESSES

*Wm A. Skindley*  
*J. Stick*

INVENTOR

*Charles B. Withington*

By *his* Attorneys

*Richard Hopkins & Payton*

C. B. WITHINGTON.  
GRAIN-BINDER.

No. 187,443.

Patented Feb. 13, 1877.

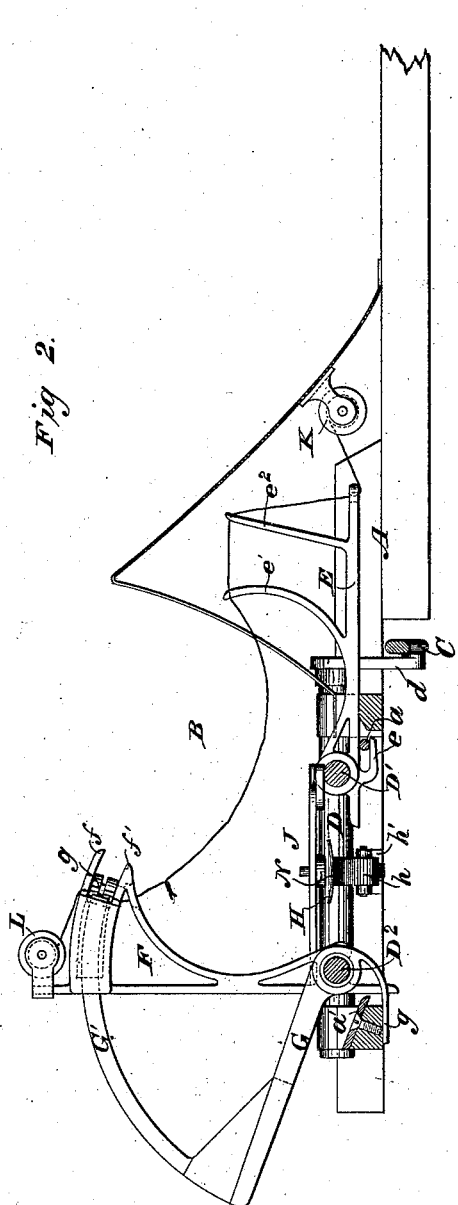

Fig 2.

Fig 4

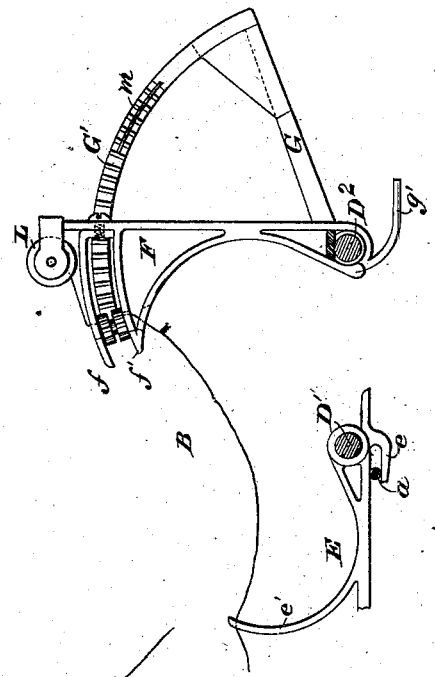
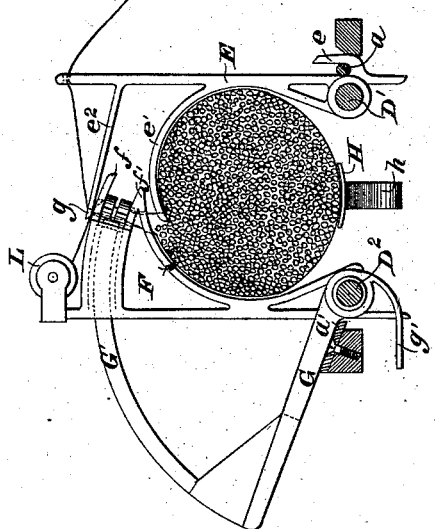

Fig 3



WITNESSES

*Wm A Sinker*  
*J. Cook*

INVENTOR

*Charles, B. Withington*

By his Attorneys.

*Baldwin, Hopkins & Bayton*

C. B. WITHINGTON.  
GRAIN-BINDER.

No. 187,443.

Patented Feb. 13, 1877.

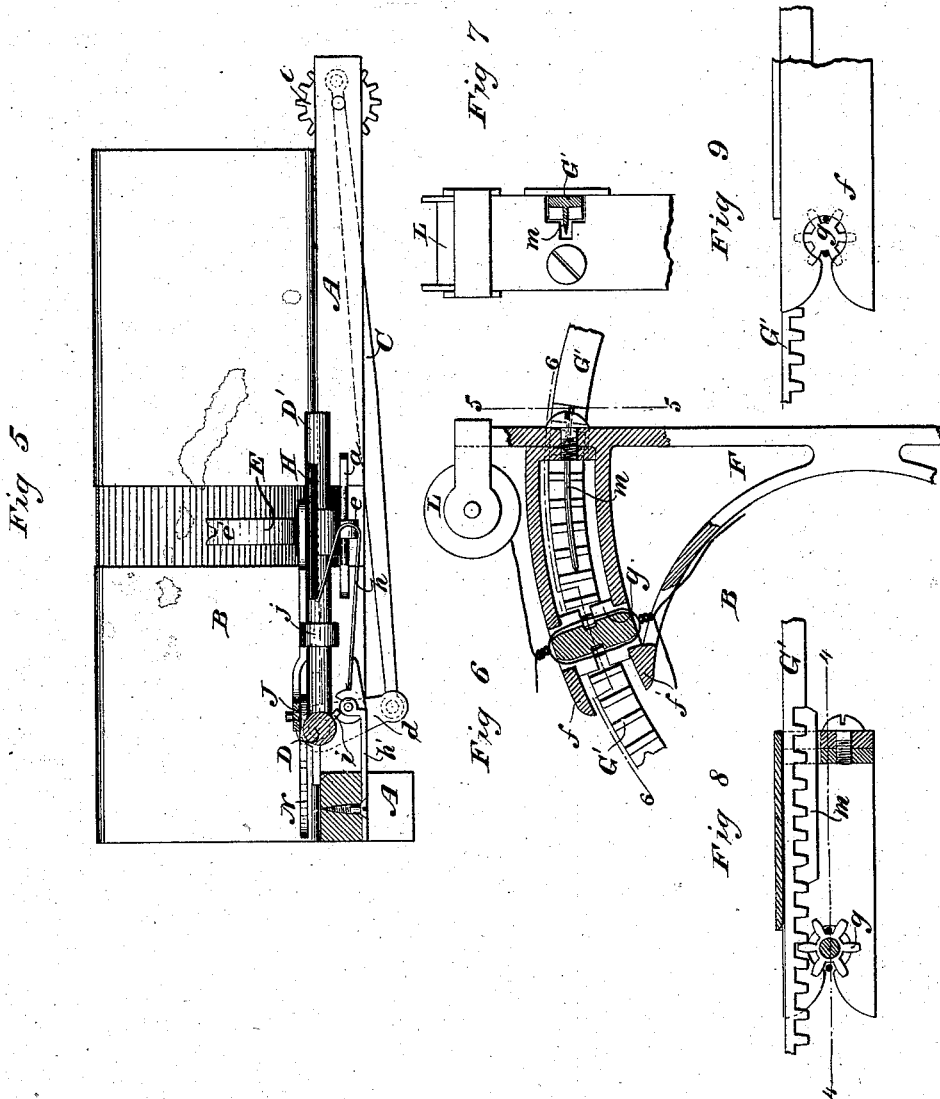

WITNESSES

*Wm A. Sindle*  
*J. Fish*

INVENTOR

*Charles B. Withington*

By his Attorneys.

*Baldwin Hopkins & Bayton*

# UNITED STATES PATENT OFFICE.

CHARLES B. WITHINGTON, OF JANESVILLE, WISCONSIN, ASSIGNOR TO C. H. AND L. J. McCORMICK, OF CHICAGO, ILLINOIS.

## IMPROVEMENT IN GRAIN-BINDERS.

Specification forming part of Letters Patent No. 187,443, dated February 13, 1877; application filed January 9, 1877.

*To all whom it may concern :*

Be it known that I, CHARLES B. WITHINGTON, of Janesville, in the county of Rock and State of Wisconsin, have invented certain new and useful Improvements in Automatic Grain-Binders for Harvesters, of which the following is a specification :

My invention relates to mechanism of that class in which the grain is bound while moving away from the receptacle.

The nature, objects, and subject-matter of my improvements will hereinafter specifically be designated.

In the accompanying drawings, Figure 1 represents a plan or top view of so much of my improved apparatus as is necessary to illustrate the subject-matter herein claimed. Fig. 2 represents a vertical longitudinal section therethrough on the line 1 1 of Fig. 1, with the binding and compressing arms open to receive the gavel. Fig. 3, a similar view on the line 1 1 of Fig. 1, with the binding-arms closed. Fig. 4 is a similar section on the line 2 2 of Fig. 1, looking toward the binding-arms, with the parts in the position shown in Figs. 1 and 2. Fig. 5 is a vertical transverse section therethrough on the line 3 3 of Fig. 1. Fig. 6, a vertical section through the twister-wheel and binding-head on the line 4 4 of Fig. 8. Fig. 7 is a vertical transverse section through the sector-rack on the line 5 5 of Fig. 6, showing the cutter. Fig. 8 is a horizontal longitudinal section on the line 6 6 of Fig. 6; and Fig. 9 is a plan view of the binding-head.

The binding mechanism is mounted on a frame, A, connected with the ordinary harvester-frame in usual well-known ways.

The grain is elevated into a receptacle, B, by means of an intermittently-moving rake or of a continuously-moving endless apron provided with a cut-off, either of which may be constructed and operated in well-known ways, so as to deliver the cut grain into the receptacle at proper intervals. The raking apparatus is not shown in the drawings.

A crank-pinion, *c*, mounted upon the frame A, and driven in any suitable manner, is connected by a pitman, C, with a crank, *d*, of a rock-shaft, D, mounted in bearings on the frame, and carrying two arms or radius-bars,

D<sup>1</sup> D<sup>2</sup>. One, D<sup>1</sup>, of these radius-bars has an arm, E, mounted thereon in such manner as to swing freely and be capable of moving endwise thereon, this arm being provided with a hook, *e*, working over a rod, *a*, on the frame, so that as the radius-bar oscillates with the rock-shaft this arm is also caused to oscillate in a path at right angles to the radius-bar. The arm E is also provided with two fingers, *e*<sup>1</sup> *e*<sup>2</sup>, forked at their front ends so as to hold the wire therein. The arm is also provided with an eye at its upper end, through which the wire passes, as shown in Fig. 2.

Another arm, F, mounted on the opposite radius-bar D<sup>2</sup>, is capable of moving endwise thereon, but not of turning, always remaining upright. This arm is also provided with two fingers, *f*<sup>1</sup> *f*<sup>2</sup>, slotted vertically in front, so as to constitute a binding-head, in which a duplex pinion, *g*, rotates. This pinion, it will be observed, is journaled on its teeth, which are cut away for that purpose; or, in other words, the teeth have their bearings directly on the walls of the perforations in the binding-head through which they pass, instead of revolving on a shaft or bearing, as usual. The central portion of the pinion is cut away horizontally; or, in other words, an annular groove is formed therein, as clearly shown in the drawing, for a purpose hereinafter described. This pinion is actuated at intervals by means of a sector-rack, G', mounted on an arm, G, turning freely, and adjustable endwise on the radius-bar D<sup>2</sup>, the rack being actuated at suitable intervals by means of a toe or wiper, *g*', which abuts against the cross-bar A<sup>1</sup> of the frame A.

A compressor, H, is mounted on a spring-arm, *h*, rocking in bearings in a bracket, *h*', on the frame. This compressor is oscillated at suitable intervals by means of a stud, *i*, on the rock-shaft D, working in a notch in an enlargement of the shaft on which the compressor rocks.

In order to adjust the binding-arms to different lengths of grain, so as to insure the binding of the bundle in the middle, a yoke, J, is provided with sleeves *j*, which encompass the radius-bars D<sup>1</sup> D<sup>2</sup>, the yoke being movable endwise thereon, and carrying the

binding-arms with it, the yoke being held in any desired position by means of a pin passing through a hole therein into a series of holes in a bar, N, secured upon the rock-shaft D.

My invention might readily be adapted to use with a single wire; but I prefer to use two wires. One wire-spool, K, is mounted on the under side of the receptacle, its wire passing through the eye of the arm E and through a notch in its fingers. The other wire-spool L is mounted on the arm F, its wire passing down through the binding-head, the two wires being twisted together, as shown in Fig. 2. These spools may be provided with well-known tension devices.

In the beginning of the operation of binding the gavel the parts assume the relative positions shown in Figs. 1 and 2, the wire-carrying arm E lying underneath the receptacle through a slot in which it works. The grain is delivered between the receptacle and the arm F carrying the binding-head upon the wire. The rock-shaft D is then operated by its gearing, in such manner as to cause its arms or radius-bars D<sup>1</sup> D<sup>2</sup> to swing downward between the cross-beams A<sup>1</sup> A<sup>2</sup> of the frame, thus forcing the wire-carrying arm forward into the position shown in Fig. 3, in which the gavel is shown as compressed between the binding head arm F and wire-carrying arm E, the compressor at the same time being thrown forward by the pin on the rock-shaft, so as to compress the gavel from beneath as well as laterally.

In this position it will be observed that the wire on one side of the gavel is at the back of the twister while the other is at its front, the wire being held both above and below the twister by the interlocking of the fingers *e* *e'* *f* *f'*, as clearly shown in Fig. 3. As the parts continue to descend the arm G strikes upon a plate, *a'*, upon the frame, and is forced inward and upward, thus causing its rack to move forward, as shown in Fig. 6, and operate the twister. At a certain point in the movement—that is, near the close of the forward movement of the rack—a knife, *m*, secured upon the face of the rack, passes through an annular groove in the twister-pinion, and severs the wire, thus relieving the bundle, and leaving the two wires twisted together above the binding-head. The movement of the rock-shaft D is then reversed, the parts swing upward, and assume the position shown in Fig. 1, the hook *e* drawing its arm E backward through the slot in the receptacle, while the wiper retracts the sector-rack, when the bound bundle drops out, and the parts are in position to repeat the operation above described.

I claim as my invention—

1. The combination, substantially as herein-

before set forth, of the rock-shaft, its radius-bars oscillating therewith, the wire-carrying arm oscillating on one radius-bar, and the binding-head arm mounted on the other, whereby the gavel is compressed and encircled with wire.

2. The combination, substantially as hereinbefore set forth, of the rock-shaft, the binding-head mounted on a radius-bar or arm of the rock-shaft, and the sector-rack oscillating on said radius-bar, whereby the wire is twisted.

3. The combination, substantially as hereinbefore set forth, of the rock-shaft, its radius-bars, the wire-carrying arms and binding-head arms, movable endwise thereon, and the adjusting-yoke, whereby said movable mechanism may be adjusted to suit different lengths of stalks.

4. The combination, substantially as hereinbefore set forth, of the rock-shaft, its radius-bars, the wire carrying arm, the binding-head arm, and the yielding compressor, actuated by the rock-shaft, whereby the gavel is simultaneously compressed on all sides.

5. The combination, substantially as hereinbefore set forth, of the rock-shaft, its radius-bars, the binding-head, mounted on one of the radius-bars, the wire-carrying arm oscillating on the other radius-bar, and the forked fingers of the wire-carrying arm, which overlap the binding-head, to insert and hold the wire therein while being twisted.

6. The combination, substantially as hereinbefore set forth, of the rock-shaft, a radius-bar mounted thereon, a binding-head carried by said radius-bar, a rack vibrating on said radius-bar, and a cutter carried by the rack, whereby the wire is twisted and severed.

7. The combination, substantially as hereinbefore set forth, of the rock-shaft, a radius-bar carried thereby, and a wire-carrying arm, oscillated on the radius-bar by its movement past a fixed portion of the frame.

8. The combination, substantially as hereinbefore set forth, of the duplex twister-pinion with a cutter reciprocating lengthwise through an annular groove in the pinion to sever the wire.

9. The combination, substantially as hereinbefore set forth, of the vertically-moving binder-head, the duplex twister-pinion, moving simultaneously with and transversely to the line of movement of the binding-head, journaled on its teeth therein, and the oscillating rack, actuating the pinion.

In testimony whereof I have hereunto subscribed my name.

CHAS. B. WITHINGTON.

Witnesses:

JOHN BIRKHOLOZ,

JOHN V. A. HASBROOK.