

W. KIRK.

HANDLES FOR SHAWL-STRAPS.

No. 187,716.

Patented Feb. 27, 1877.

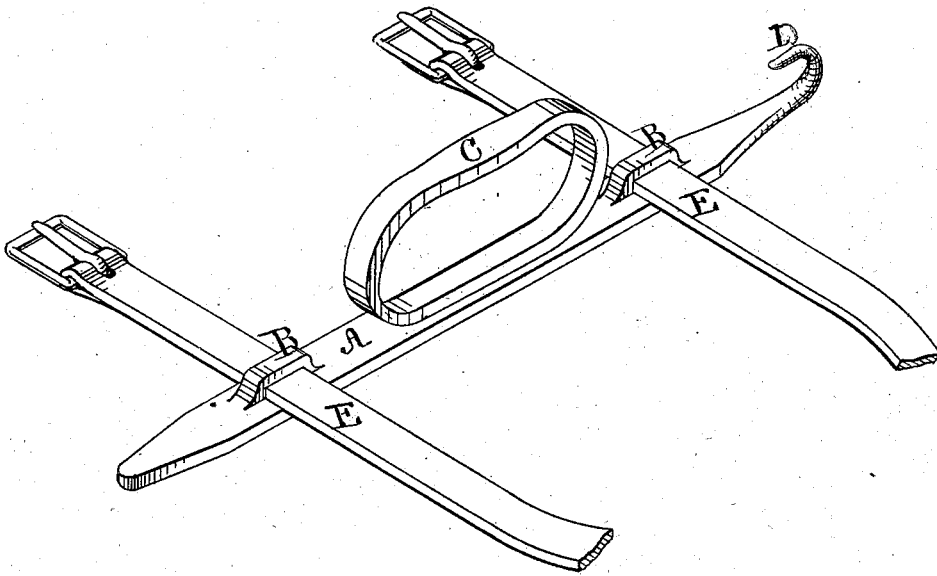

Witnesses.

*William H. Low.*

*C. J. Mattison*

Inventor.

*William Kirk*

# UNITED STATES PATENT OFFICE

WILLIAM KIRK, OF ALBANY, NEW YORK.

## IMPROVEMENT IN HANDLES FOR SHAWL-STRAPS.

Specification forming part of Letters Patent No. **187,716**, dated February 27, 1877; application filed January 2, 1877.

*To all whom it may concern:*

Be it known that I, WILLIAM KIRK, of the city and county of Albany, and State of New York, have invented certain new and useful Improvements in Handles for Shawl-Straps, of which the following is a full and exact description, reference being had to the accompanying drawing, making a part of this specification, in which a perspective view of my improved handle is shown.

The object of my invention is to remedy certain well-known defects in shawl-strap handles as heretofore constructed. One of these defects consists in the liability of the flexible handle and cross-bar commonly used to bend under the strain of a heavy bundle, so as to bring the handle and cross-bar into such close contact as to squeeze the hand of the carrier in a most painful manner. Another defect therein consists in the absence of any provision for suspending the strap and its inclosed contents to any available portion of railway-cars or other public conveyances, from which cause these bundles have frequently to be deposited on the floor in the midst of dirt, and to the great detriment of the goods they contain.

As shown in the drawing, A is the cross-bar, which I preferably cast of any metal having the requisite strength and rigidity. On its upper face it is provided with the loops B

for receiving the straps, and with the handle C for carrying it, which may be a constituent part of the cross-bar, or it may be made separately and secured to the cross-bar by rivets or other suitable means. When made separately it should be made of metal sufficiently strong and rigid to resist any tendency to bend when heavy packages are carried. At one end of the cross-bar A a hook, D, is formed, by means of which the parcel or bundle secured in the straps E may be hung upon the baggage-racks or other convenient parts of the car or conveyance. This hook I prefer to cast with the cross-bar A; but when desirable it can be made separately and attached to the cross-bar in any suitable manner.

It is obvious that these handles may be made of any tasteful design, and finished in such manner as to render them a very ornamental as well as a most convenient and useful article for travelers' use.

I claim as my invention—

The shawl-strap handle herein described, consisting of the cross-bar A, provided with a metallic handle, C, and hook D, substantially as and for the purposes set forth.

WILLIAM KIRK.

Witnesses:

WILLIAM H. LOW,  
C. J. MATTESON.