

W. H. LANG.  
PUMPS FOR TOWN AND CITY SUPPLY.  
No. 187,719. Patented Feb. 27, 1877.

*Fig. 1.*

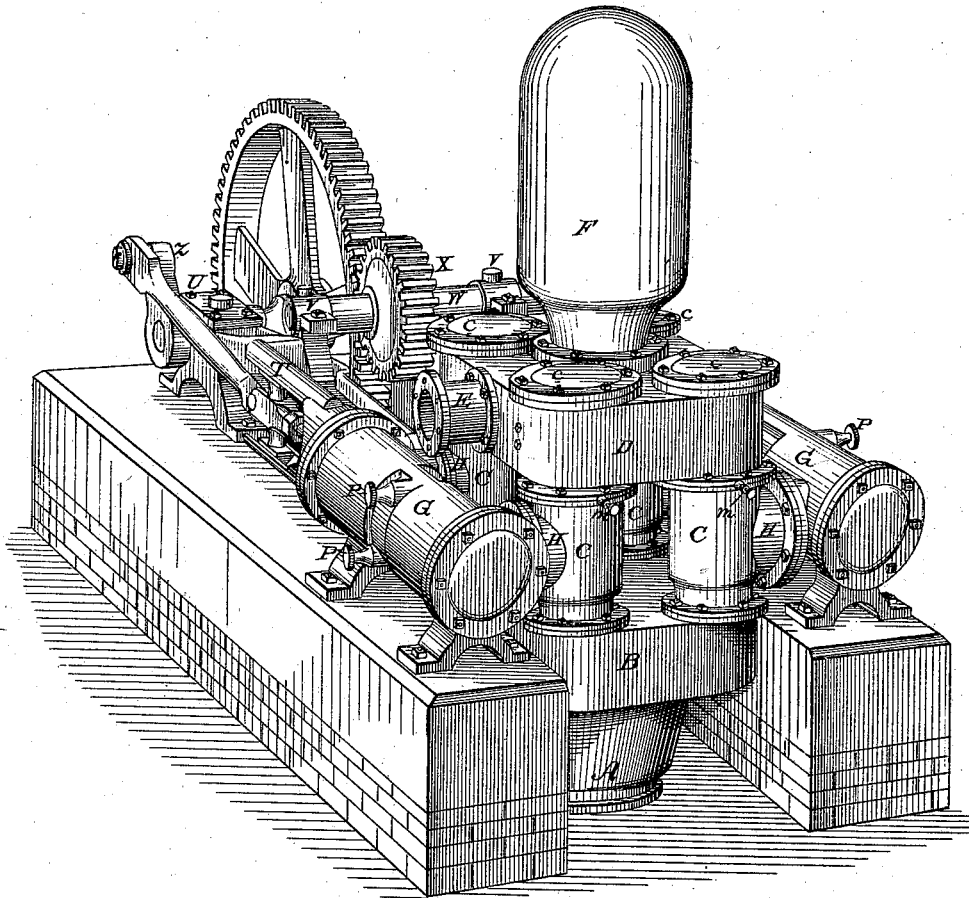

*Attest:*

*Clarence Poole*  
*E. B. Hayes*

*Inventor:*

*Wm. H. Lang*  
*Boylston City*  
*R. D. O. Smith*

W. H. LANG.

PUMPS FOR TOWN AND CITY SUPPLY.

No. 187,719.

Patented Feb. 27, 1877.

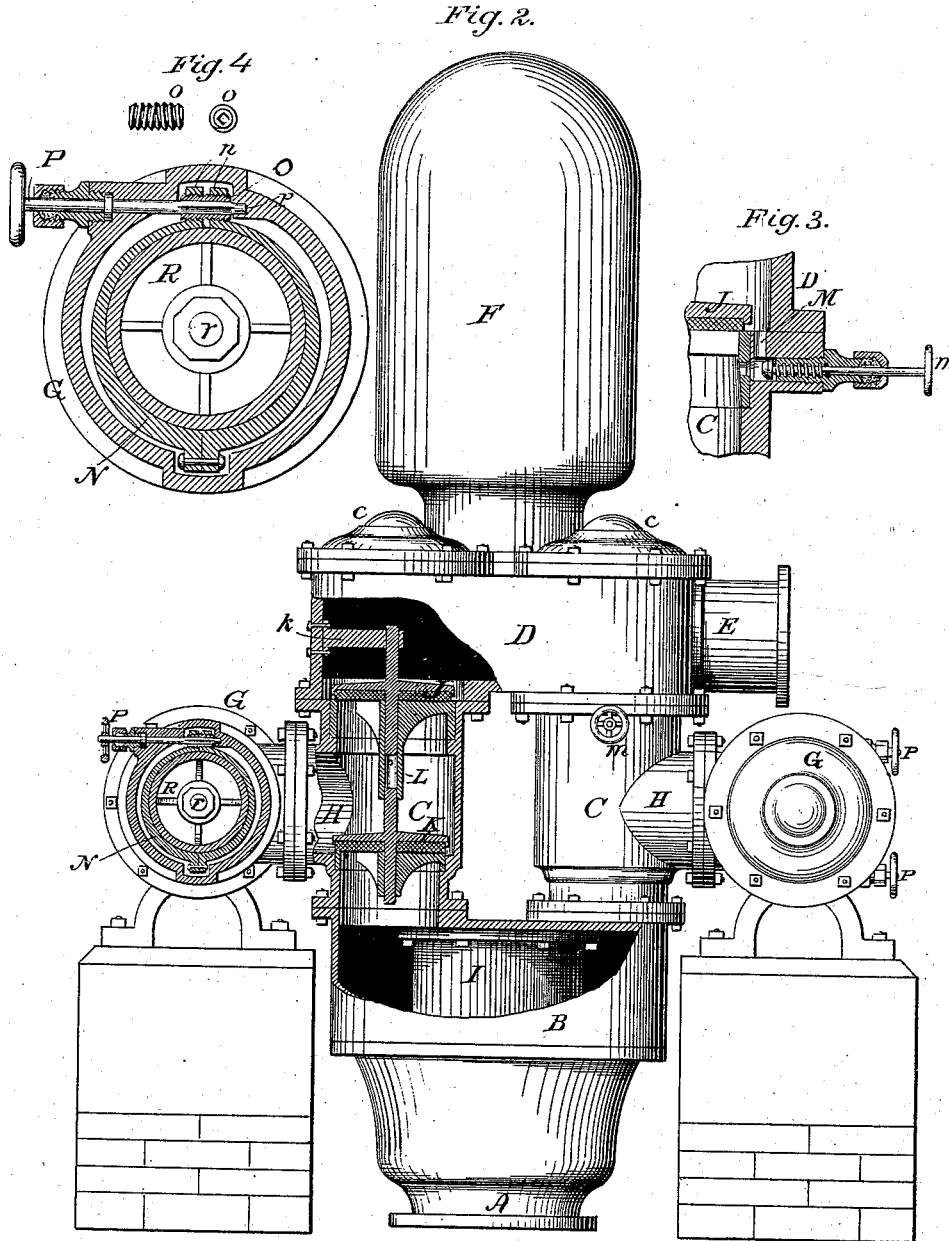

Attest:

Clarence Poole  
E. B. Hayes

Inventor:

W. H. Lang  
By his atty  
R. D. O. Smith

W. H. LANG.  
PUMPS FOR TOWN AND CITY SUPPLY.  
No. 187,719. Patented Feb. 27, 1877.

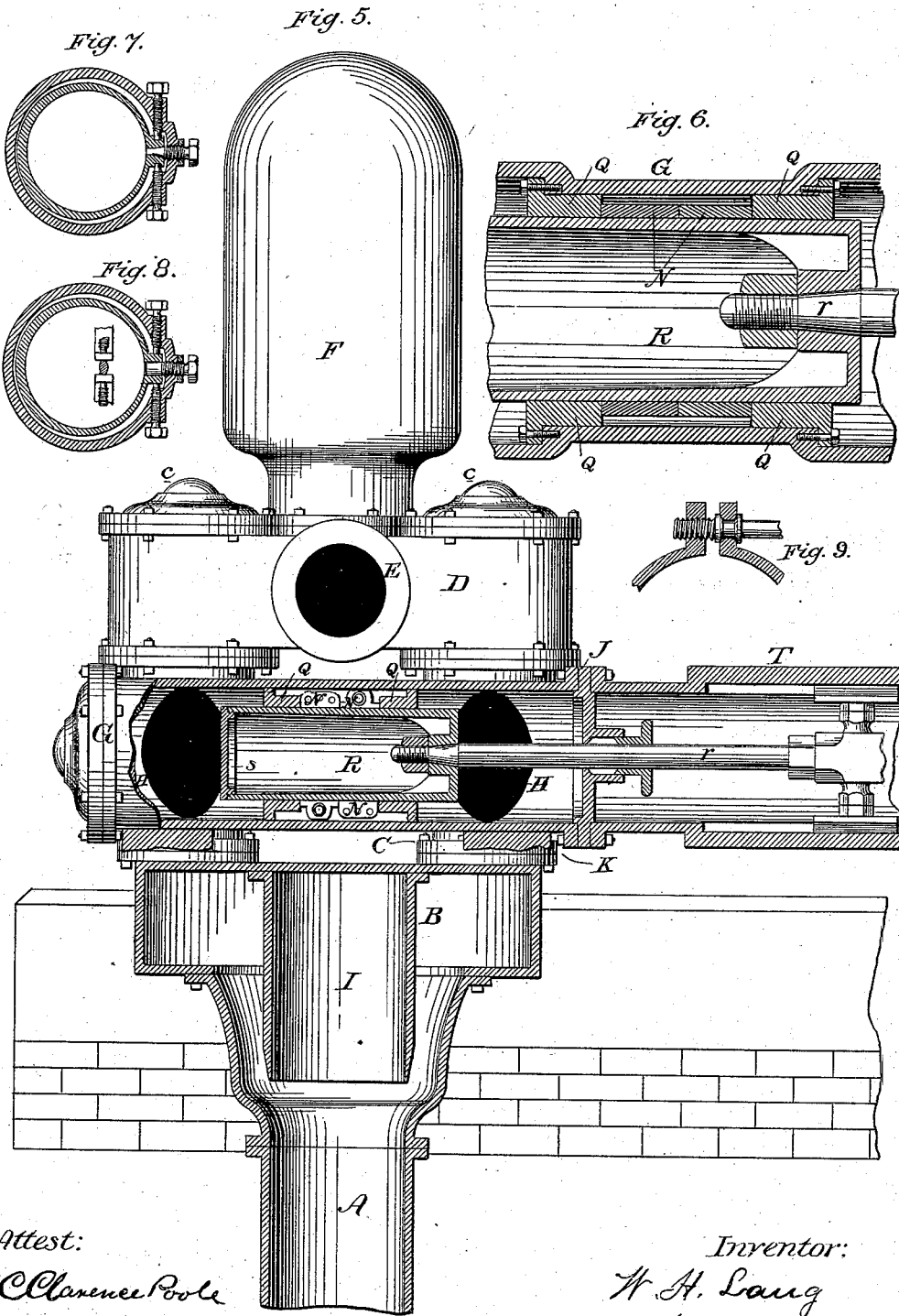

Attest:  
Clarence Poole  
E. B. Hayes

Inventor:  
W. H. Lang  
By his atty  
R. D. C. Smith

# UNITED STATES PATENT OFFICE.

WILLIAM H. LANG, OF VERGENNES, VERMONT.

## IMPROVEMENT IN PUMPS FOR TOWN AND CITY SUPPLY.

Specification forming part of Letters Patent No. 187,719, dated February 27, 1877; application filed January 18, 1877.

*To all whom it may concern:*

Be it known that I, WILLIAM H. LANG, of Vergennes, in the county of Addison and State of Vermont, have invented a new and useful Improvement in Pumps for Town and City Supply, of which the following is a full and clear description:

This invention relates to that class of pumps which are adapted and intended for the supply of cities and towns, and especially for pumping into the mains direct.

The duty required of pumps for this purpose is very heavy; and the object of this invention is, first, to arrange the lower check-valves in relation to each other, and to an air-chamber in the suction-pipe, so that said valves shall all be equally relieved of the ram which results from the alternate stopping and starting of a current of water under heavy pressure; second, to keep the upper and lower valves always in line by making the hollow axial sleeve of the upper seat, which guides the lower spindle of the upper valve, serve also as a guide for the upper spindle of the lower valve; third, to readily prime the lower valves and pump from the upper receiver or main by means of a small return water-way past the upper valve-seat, and a suitable valve to open or close said water-way; fourth, to preserve proper packing of the plunger without unnecessary pressure by means of stationary packing-rings having positive adjustments independent of the pressure in the water-ways; fifth, to make the packing-rings adjustable without stopping the pump by means of a rod or stem which projects through the side of the pump-cylinder; sixth, to relieve bottom wear upon the plunger and packing by means of a buoyant plunger, so that its weight will be supported by the water within which it is acting, instead of by the packing or bearings.

That others may fully understand my invention, I will more particularly describe it, having reference to the annexed drawings, wherein—

Figure 1 is a perspective view of my pump, with two double-acting cylinders. Fig. 2 is a front sectional elevation of the same. Fig. 3 is a sectional elevation, showing the priming-valve. Fig. 4 is an elevation of one of the packing-rings. Fig. 5 is a side sectional ele-

vation on line *xx* of Fig. 2. Fig. 6 is a longitudinal sectional elevation of the cylinder, showing the lining and packing rings. Figs. 7, 8, 9 represent modified devices for the positive adjustment of the packing-rings.

My pump may be either single or double acting, as to make it double-acting only requires a duplication of those parts which are required for a single-acting pump. For heavy duty in pumping for city or town supply, it is preferable to couple two double-acting pumps, as shown in the annexed drawings; but as said pumps are duplicates it will only be necessary to describe the operative parts of one.

A is the suction-pipe through which water is drawn from the well or other source of supply. The pipe A discharges into the chest B, from whence the water passes into the valve-chest C, and then into the receiver D, and is finally discharged into the service-pipe E. An ordinary air-chamber, F, is placed upon the receiver D, to absorb the shock of the water-ram in the main, and to maintain a continuous flow.

The pump-cylinder G is located at the side of the valve-chest C, and takes water therefrom through the port H, midway between the valves J and K in said chest, alternately drawing in and discharging through said port. These are general features, and in that respect are similar to other plunger-pumps; but in the particular structure and arrangement of the parts of my pump, it is dissimilar to other pumps in the particulars referred to in the claims.

The heavy duty to which pumps of this class are subjected causes a correspondingly heavy reaction upon the valves whenever the forward flow through the valve ceases; and the result of this ram is a rapid pounding out and destruction of the valve and seat, and the final disabling of the pump. The ordinary air-chamber F relieves the ram on the upper check-valve J, and I place an air-chamber, I, within the chest B, and opening downward into the suction-pipe A, to relieve the lower check-valves K from the ram of the ascending column of water in the suction-pipe, when its flow through one of the valves K is momentarily checked by the reversal of the pis-

ton-stroke. The air contained in the chamber I will then cushion said check and take up the shock.

In my pump, as shown—viz., having two double-acting cylinders coupled to the same suction-pipe and receiver—the piston-rod cranks are set at right angles to each other, so that one or the other is always in positive action. The four-valve trunk C is placed upon the chest B, equidistant from the center of the chamber I, so that each of the valves K is equally benefited by the air-cushion in said chamber.

It is desirable that all the valves shall be accessible and easily put in place or removed when required, and I therefore make the chest C with a recess near the top for an upper valve-seat, and a smaller recess near the bottom for a lower valve-seat, so that the lower seat may be passed downward into place through the upper end of said chest. The removal of the single cover *c* therefore makes both the valves J and K and their seats accessible and easily removable.

The flow of water through the valves and clearance therefrom is necessarily more or less in a lateral direction, causing an unequal wear upon the valve and seat, which is finally destructive to both valve and seat. To counteract this defect, I construct my valve with an axial spindle projecting above and below the disk of the valve, and provide guides for the same, both above and below the seat. The valve is thereby compelled to move in a straight line, and the unequal wear is obviated.

It is undesirable to obstruct the water-ways with projecting parts for guides; and I therefore construct the valve-seats with long axial tubes or sleeves L depending from them, to serve as guides for the valve-spindles, the sleeve L of the upper seat serving as a guide for the lower spindle of the valve J, and for the upper spindle of the valve K, and I thereby economize space, material, and labor, and also avoid obstructing the water-ways more than is absolutely necessary. The upper spindle of the valve J is guided by an arm, *k*, which is bolted to the side of the receiver D.

When the pump is out of service and is empty of water it is necessary to prime the valves to prevent them from leaking air when first started, and for this purpose I have arranged a small water-way, M, from the receiver D downward past the seat of the valve J into the valve-chest C, and stop the same by a valve, the rod *m* of which projects out through a stuffing-box on the side of said chest, so as to be accessible to the hand of the attendant.

In double-acting plunger-pumps tight packings are necessary, and stationary metallic rings are generally employed; but heretofore, when said rings have been adjustable at all, they have been automatic in their adjustment, and liable to variation in their pressure upon the piston, according to the pressure of the

water in front of the piston. This packing-pressure is sometimes so excessive that the operation of the pump is impeded. I have, therefore, constructed the packing-rings N with positive adjustment, entirely independent of cylinder-pressures, and, therefore, entirely uniform under all circumstances. This purpose I effect by making an elastic ring, N, with sufficient stiffness to withstand the compression of water-pressure behind it, and having cut this ring transversely on one side, I place between the ends a device which may be caused to open or close the said cut, and thereby expand or contract the interior caliber of said ring positively, and without reference to the pressure upon the outer periphery of the ring. The interior curve should always be circular under all adjustments, and this may be effected by forming the ring with the inner and outer faces eccentric to each other, as shown.

In practice I prefer to form the ring N with lugs *n n*, through which a right-and-left screw-plug, O, is inserted, so that by rotating said plug in one direction, said lugs may be drawn together, and by turning it in the opposite direction they will be forced asunder.

I am aware that steam-piston packing-rings have been constructed with positive adjustments; but in those cases the packing-rings were placed upon and moved with the piston, and therefore incapable of adjustment without removing the cylinder-head. These, therefore, are dissimilar from mine, which may be adjusted from the outside at any moment, whether the machine is in action or at rest.

Lengthwise through the screw-plug O an angular hole is made to receive the square of the rod-key P, whereby said plug O may be rotated and the rings adjusted at any moment, whether the pump is at rest or in motion. The rod P passes through a stuffing-box on the side of the cylinder, to prevent leakage, and its inner end may be seated in a socket, *p*, and thereby caused to support the weight of the ring N, and to that extent prevent an unequal wear of the ring and plunger.

The adjustment of the rings N may be effected positively in a variety of ways, which will readily suggest themselves to a skillful mechanic, and three such methods are shown in Figs. 7, 8, 9; but the right-and-left screw first described is preferred on account of simplicity, compactness, and cheapness.

The edges of the packing-rings N are accurately fitted to each other and to the linings Q, so as to prevent the passage of water behind said rings, and to effect this object as perfectly as possible it is preferred to employ two packing-rings, N, arranged with the adjusting-screws at opposite sides of the cylinder, so that said rings will break joints with each other.

It is well known that in all horizontal steam or pump cylinders the weight of the piston causes greater friction along the lower side of the cylinder than elsewhere, and, consequently, both piston and cylinder are worn "out of

round." This is recognized as a serious defect, and I propose to obviate it, so far as pumps are concerned, by making the plunger buoyant in water, and thereby it will constantly tend to rise from the bottom, and the excessive friction there will be obviated.

This effect may be most readily produced by means of an air-chamber within the plunger R, as shown, though it may be produced by making the body of said plunger of a substance having a specific gravity less than that of water. I therefore prefer to make the plunger R hollow, with a re-enforced head to receive the piston-rod *r* at one end, and a close cap, *s*, at the other end, so as to make a sealed air-chamber of the interior space. By suitably adjusting the weight of the piston-plunger R and a portion of the rod *r* to the displacement of said plunger, (an equal portion of which is always submerged,) the friction upon the cylinder and linings may be made practically uniform at all points.

The pistons of my pump may be driven by any suitable power and intervening mechanism; but the arrangement of frame and gearing shown in my drawings is preferred.

It will be observed that the chest B and receiver D are similar, and may be cast from the same pattern, the only difference being in the presence or absence of flange-plates—a practice of substitution common in the art of molding. The chest B and receiver D are joined at the four corners by valve-chests C C C C, which are also similar, and may be cast from the same patterns. The cylinders G are likewise similar, and may be cast from the same patterns; therefore, the cost for patterns is reduced, the parts are made interchangeable, and the number of mechanical operations and tools required in the fitting of the several parts is correspondingly reduced. In like manner the engine-frames T, with the pillow-blocks U, are similar.

Motive power is applied to the shaft W of

the driving-pinion X, and thereby transmitted to the main wheel Y and crank Z.

Having described my invention, what I claim as new is—

1. A vacuum-chamber, I, inclosed within the inlet-chamber B, in combination with the inlet-valves K, to prevent the reaction or ram caused by the sudden starting and stopping of water as it is drawn alternately through each valve, substantially as set forth.

2. The valves J and K, combined with their seats, provided with the hollow axial sleeve L, whereby the lower spindle or stem of one valve and the upper spindle or stem of the other of said valves are guided.

3. In combination with the upper and lower valves J and K and the inclosed chamber, the priming-valve in the channel M.

4. The stationary elastic packing-ring N, divided on one side, and combined with a device adjustable from the outside while the machine is in motion, whereby the same may be positively adjusted, substantially as set forth.

5. The stationary elastic packing-ring N, divided on one side, combined with the right-and-left adjusting-screw O, capable of being operated from without the cylinder, substantially as set forth.

6. The elastic packing-ring N and its adjusting-screw, combined with the loose key P, substantially as described.

7. A horizontal pump-cylinder, combined with a buoyant piston, R, to prevent excessive friction on the bottom of said piston and its packing, substantially as set forth.

8. The chest B, with the suction-pipe A at its center below, the valve-chests C C C C, receiver D, with the air-chamber F, placed over its center, and the cylinders G G, all arranged in relation to each other, substantially as shown and described.

Witnesses: WILLIAM H. LANG.

WM. E. GREENE,

J. M. HAWRICAN.