

J. R. BROWN, dec'd.  
C. D. OWEN and L. SHARPE, Executors.  
GRINDING MACHINE.

No. 187,770.

Patented Feb. 27, 1877.

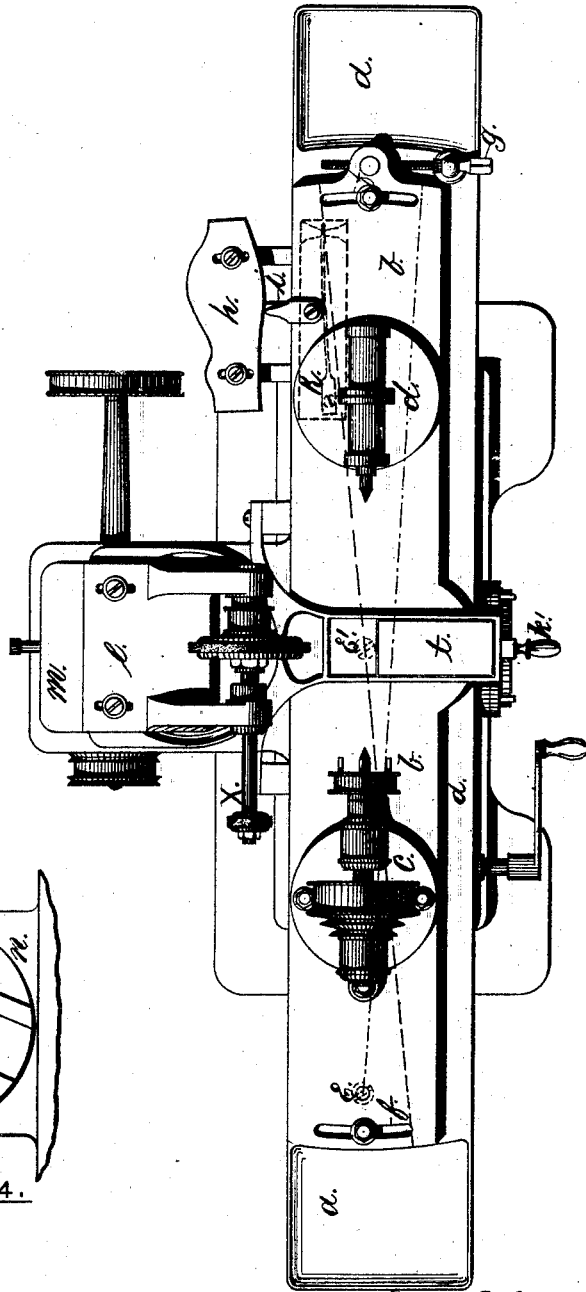

FIG. 1.

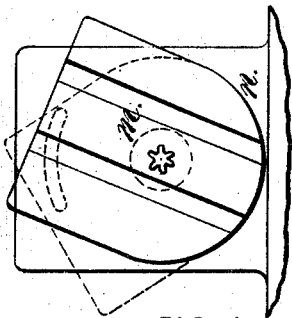

FIG. 4.

WITNESSES.

*Ernest C. Barth*  
*L. Langworthy*

INVENTOR.

*Charles D. Owen & Lillian Sharp*  
 Executors of  
*Joseph R. Brown, dec'd.*

*By Joseph A. Miller*  
 ATTORNEY.

J. R. BROWN, dec'd.  
C. D. OWEN and L. SHARPE, Executors.  
GRINDING MACHINE.

No. 187,770.

Patented Feb. 27, 1877.

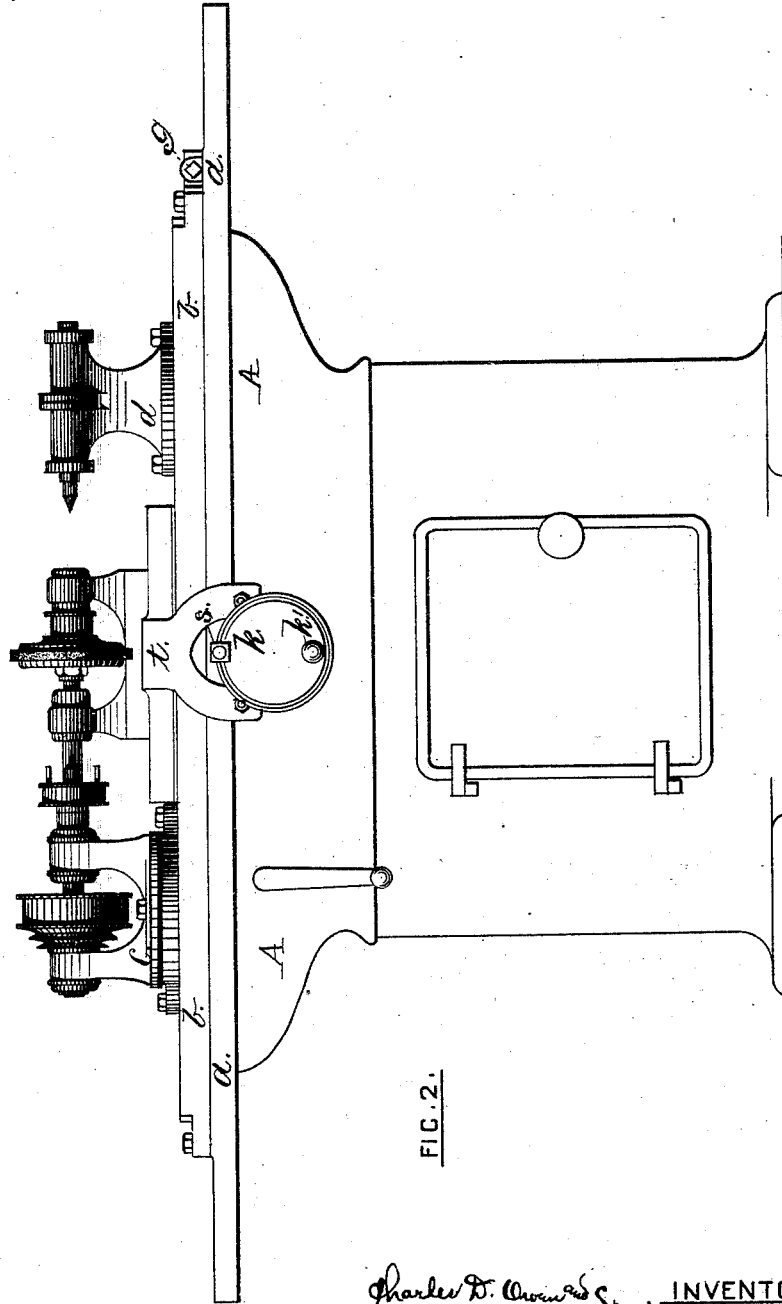

FIG. 2.

WITNESSES.

Ernest C. Barth.  
L. P. Langworthy

Charles D. Owen and Lucian Sharp. INVENTOR.  
Executors of  
Joseph R. Brown, dec'd.  
by Joseph A. Miller  
ATTORNEY.



# UNITED STATES PATENT OFFICE.

CHARLES D. OWEN AND LUCIAN SHARPE, OF PROVIDENCE, RHODE ISLAND,  
EXECUTORS OF JOSEPH R. BROWN, DECEASED.

## IMPROVEMENT IN GRINDING-MACHINES.

Specification forming part of Letters Patent No. 187,770, dated February 27, 1877; application filed  
October 28, 1876.

### *To all whom it may concern :*

Be it known that JOSEPH R. BROWN, deceased, late of the city of Providence, in the county of Providence and State of Rhode Island, did invent certain new and useful Improvements in Grinding-Machines; and we hereby declare that the following is a full, clear, and exact description of the same, reference being had to the accompanying drawings, forming part of this specification.

Figure 1 is a top view of the improved grinding-machine. (The two broken lines indicate the position of the center-line of the table to which the head and foot stocks are secured when the table is swung on either the central or the end pin.) Fig. 2 is a front elevation of the machine. Fig. 3 is an enlarged sectional view through the center of the grinding-machine, the base being shown as broken off. Fig. 4 is a plan view of the laterally-swinging base-plate, on which the wheel-arbor is supported, in different positions.

The object of this invention is to so construct a grinding-machine that the same shall be adapted to do a great variety of work—a machine on which straight, tapering, curved, and irregular work, either inside or outside, can be ground with great accuracy.

The nature of the invention consists in the arrangement of the parts, by which the relative positions of the table, the head and foot stocks, and the wheel-arbor, can be adjusted to adapt the same to a great variety of work and under all the changes control the adjustment with the greatest nicety.

The grinding-machine is shown in Fig. 2 as supported on a base, which is provided with a convenient closet for holding wheels and such parts or attachments as are not in use. Firmly secured to this base is the stationary bed-plate A, provided with longitudinal grooves, similar to those of a planing-machine. In these grooves the table *a* reciprocates, being operated by a rack and pinion, or in any other manner. To protect the grooves and the feed-works from grit and dust, the reciprocating table *a* is made of such length as to always cover the bed-plate. To the reciprocating table *a* the adjustable table *b* is secured by the pin *E'* at the center of the table *b*, or by the

pin *E* at or near the end of the table *b*, and by the clamp-screws in the segmental slots *ff*. By these means the table *b* may be adjusted to any desired angle within the limits of the slots *ff*, and when the ends (either one or both) of the table *b* are arranged with graduated indexes divided into degrees and fractions thereof, the adjustable table *b* may be accurately set to any desired angle, and tapering work may be ground with great accuracy. To secure accurate adjustment, the table *b* is provided with the adjusting-screw *g*.

When curved and irregular work is to be ground, the pin on which the table swings is placed near the end of the table at *E*, the adjusting-screw *g* is detached from the table, the pattern *h* is secured to the brackets, so as to be in contact with the finger *i*, the spring *k*, secured to the table *a*, keeps the finger *i* in contact with the pattern *h*, so that in its reciprocation the table *b*, and the head and foot stocks which are secured to the table *b*, will be brought nearer to or farther from the grinding-disk, and, with them, the work to be operated upon, and the motion will be governed by the configuration of the pattern *h*, and irregular forms may be accurately ground.

In place of the spring *k* the table *b* may be held so that the finger *i* will rest against the pattern by a weight secured to a chain, the other end being secured to the table, which chain passes over a pulley, so that the table will follow the configuration of the pattern. The pattern *h* may be readily produced by placing a steel disk on the wheel-mandrel and securing a tracing-point to the finger *i*, and the irregular article in its finished state is placed between the head and foot stock, and the table *b* reciprocated, thus marking the exact line of the configuration required in the pattern, all projections being double or nearly double the projections on the article. The head-stock *O* is also arranged to turn on a vertical center, and can thus be adjusted independent of the table *b*, and obtuse angles, either outside or inside, may be readily ground. When required, the circular base of the head-stock *O* is provided with a graduated index, so that the same may be set at any desired angle and firmly secured by the clamp-screws provided.

The wheel arbor and stand are supported on the base *l*, which is adjustably secured by clamp-screws to the swinging base *m*. (Shown enlarged in Fig. 4.) By this arrangement the wheel-arbor can be adjusted to any desired angle. The swinging base-plate *m* is pivoted by a pin or screw to the center of a boss on the reciprocating base *n*, which base *n* is provided with the internal gear *o*; a pinion secured to a shaft, which also forms the pivot on which the swinging base *n* may be turned in any direction and secured by the clamp-screw *n*<sup>2</sup>.

The pivot on which the base *n*<sup>1</sup> swings is provided at its upper end with the pinion, which gears into the rack-gear *o*, and at its lower end with the bevel-gear *p*, and as this pivot forms the center on which the base *n*<sup>1</sup> swings the wheel-arbor may be adjusted or reciprocated in any direction, as the pinion will in every direction gear into the rack *o*, as is clearly shown in Fig. 3. The bevel-gear *p* engages with the bevel-gear *q* secured to the horizontal shaft *q'*, which extends to the front of the machine, and is provided with the disk *k* and the handle *k'*. The face of the disk *k* may be graduated, so that the exact position of the grinding-disk may be known; and to facilitate the operation the clamp *s* is placed on the disk *k*, and two pins are placed on the stationary part of the machine, arranged so that when the clamp rests against the pin on the right-hand side the grinding-disk is at its proper place, and when the clamp rests against the pin on the left-hand side the grinding-disk is clear off the work. The gradual wearing of the grinding-disk is compensated by a slight adjustment of the clamp *s*.

By this arrangement the operative can concentrate his attention on the work, and can feel when the grinding-disk is in its proper position without examining the index on the disk *k*.

The back rest *U* and the cover *V* are shown in Fig. 3, to indicate their relative positions.

The wheel-arbor is arranged to extend beyond the bearings, and is provided with a smaller grinding-wheel, so that holes or cylinders may be ground inside, or by the use of the pattern *h*, with its curved sides.

*t* is a bridge, secured to the stationary part of the machine, and arranged to extend over the tables *a* and *b*, and is provided with a pan or recess, to receive the grit and water from the grinding-wheel. To this bridge *t* the back rest also is secured.

This machine is specially adapted for circular grinding where accuracy and uniformity are required, such as hardened plugs, arbors, spindles, reamers, cutters, &c. It will grind straight, tapering, or curved, either inside or outside, and any angle, obtuse or otherwise, can be readily produced.

Having thus described the invention, we claim as new and desire to secure by Letters Patent—

1. In a grinding-machine, the combination, with the bed-plate, of a reciprocating table,

the latter made of sufficient length to cover the bed-plate through the limit of travel of the table, and thereby prevent the ingress of dust or cuttings into the groove in said bed-plate, substantially as set forth.

2. In a grinding-machine, the combination with a reciprocating table, of a table resting thereon, the latter secured to the reciprocating table, and provided with means to change its pivotal movement from its center to one of its ends, and thus move about a central or an end pivotal bearing-pin, substantially as and for the purpose set forth.

3. In a grinding-machine, the combination with a reciprocating table, of a pivotal or vibrating table resting thereon, the latter serving as a support for the head and foot stocks of the machine, said pivotal table being provided with an adjusting-screw, *g*, whereby the pivotal table may be secured at any desired angle to the line of travel of the reciprocating table, substantially as and for the purpose set forth.

4. The combination, with the wheel-arbor base; secured to a pivoted base, of the lower swinging base *n*<sup>1</sup>, and the intermediate reciprocating base *n*, substantially as and for the purpose set forth.

5. The combination, with the reciprocating base *n*, pivoted base *m*, and wheel-arbor base *l*, of an actuating and pivotal shaft, the same provided with a pinion to engage with a rack secured to the reciprocating base, and with a gear-wheel which meshes with a corresponding gear secured to the main actuating-shaft, substantially as and for the purpose set forth.

6. The combination, with a wheel-arbor constructed to have a pivoted and reciprocating movement, of an actuating-shaft, which also serves as a pivotal bearing for the lower base of the grinding-wheel, said shaft having a pinion secured to its upper end for engagement with a rack on a reciprocating base, and with a bevel-gear on its lower end which meshes with a corresponding gear-wheel secured to the end of the adjusting-shaft, substantially as and for the purpose set forth.

7. The combination, with the shaft *q'*, arranged at right angles to, and beneath, the bed-plate of the machine, of a vertical actuating and pivotal shaft, for imparting movement to the grinding-wheel, the shaft *q'*, provided with a suitable hand-wheel, for operating the same, substantially as and for the purpose set forth.

8. The combination, with the laterally-adjustable wheel-arbor, having a grinding-wheel secured thereto outside of the arbor-bearings, of the head-stock, pivoted to the vibrating table, whereby the machine is adapted for grinding the inner and outer surfaces of articles secured thereto, substantially as and for the purpose set forth.

9. The combination, with the wheel-arbor of a grinding-machine, constructed to have both horizontal and pivoted adjustment, substantially as set forth, of an adjusting-shaft

provided with the disk *k* and clamp *s*, and stop-pins secured to the stationary portion of the machine, substantially as and for the purpose set forth.

10. In a grinding-machine, the combination, with the head and foot stocks, adapted to be adjusted both laterally and longitudinally, of a grinding-wheel constructed to be adjusted

both laterally and pivotally, substantially as and for the purpose set forth.

CHAS. D. OWEN,  
LUCIAN SHARPE,  
*Executors.*

Witnesses:

JOSEPH A. MILLER,  
AMOS A. WHITE.