

L. WINSLOW.  
STRAW-CUTTER

No. 187,791.

Patented Feb. 27, 1877.

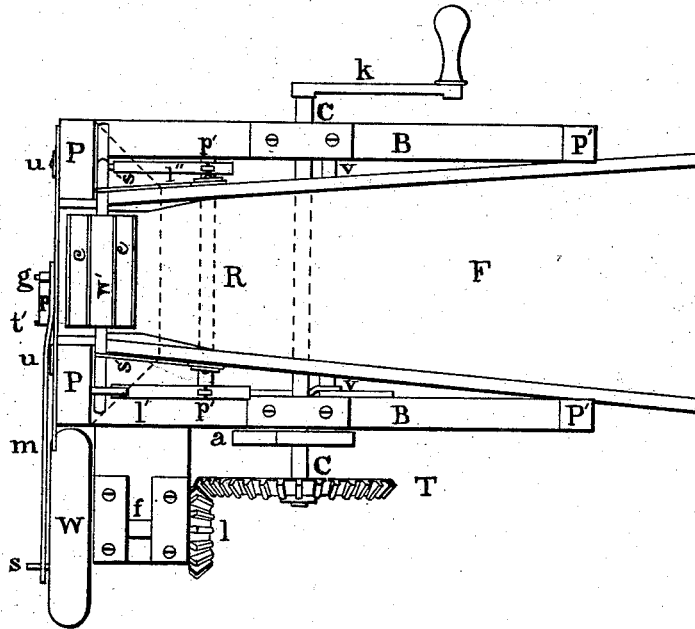

Fig. 1.

Fig. 2.

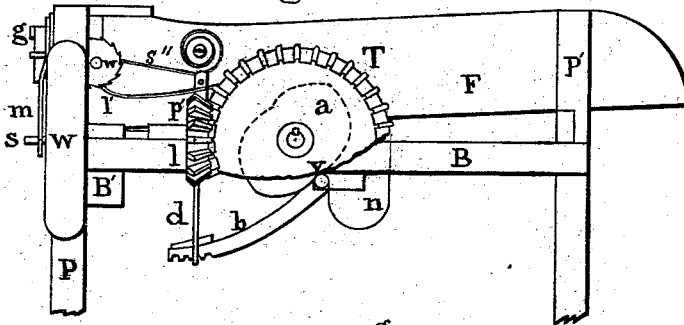
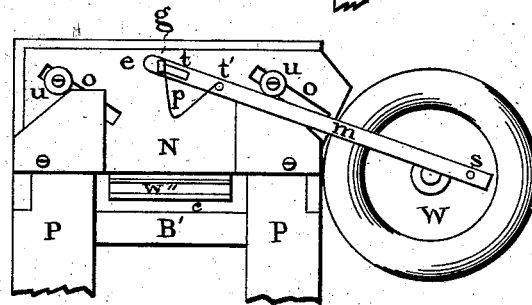

Fig. 3.



Witnesses;

*John Hay*  
*John Thomson*

Inventor;

*Lorenzo Winslow*

# UNITED STATES PATENT OFFICE.

LORENZO WINSLOW, OF ROCHESTER, NEW YORK.

## IMPROVEMENT IN STRAW-CUTTERS.

Specification forming part of Letters Patent No. 187,791, dated February 27, 1877; application filed May 3, 1876.

*To all whom it may concern:*

Be it known that I, LORENZO WINSLOW, of the city of Rochester, in the county of Monroe and State of New York, have invented certain new and useful Improvements in Straw-Cutters; and I do hereby declare that the following is a full, clear, and exact description of the construction and operation of the same, sufficient to enable those skilled in the art to which it appertains to construct and make use of the invention, reference being had to the drawings accompanying this specification, and to the figures and letters of reference marked thereon, in which like letters refer to like parts throughout the same, and on which—

Figure 1 represents the top of the invention. Fig. 2 represents the side of the invention. Fig. 3 represents the end of the invention.

The first part of my improvement relates to the cutter-knife and devices for actuating the same.

The second part of the improvement relates to feed-rolls, and the manner of their operation; and the third part relates to mechanism regulating the feed to the cutting apparatus.

Its object is, first, to produce for the knife a peculiar drawing cut; second, for the purpose of sharpening, to readily and easily release the same; and third, to increase the number of knife motions in proportion to the revolutions of the crank.

It consists, first, in a diagonally and vertically operating disk-knife, which acts by means of diagonal slots on retaining flanged stubs, to which motion is given by an arm extending from a balance-wheel, which wheel, by means of bevel-gearing attached to one side of the frame, is driven by a hand-crank; second, in a compound cam affixed to the crank-shaft actuating the pallets and pawls, and regulating the feed-rolls; also, in springs, by which said rolls and pawls are held in position, which will now be described.

In the drawing, P represents the two front corner-posts, P' the two rear ones, B the side, and B' the end, bars constituting the frame of the machine, which is constructed in the man-

ner and of the kind of material and dimensions preferred.

By suitable appliances the crank-shaft C is transversely attached to said bars B, at one end of which shaft is the crank *k*, while to the other is, meshing into the small wheel *l*, the bevel-wheel T. This wheel *l* by the shaft *f*, in being supported by an extension of the bar B', rotates the balance-wheel W, and the wheel W by the arm *m*, which has one end by the pin *s* attached to the front disk of the wheel, and the other by the lug *g* to the knife N, actuates said knife, giving it, at the same time, by the diagonal slots *o* and flanged stubs *u*, both a vertical and diagonal movement, which movements, combined, produce a drawing cut, in which action the shape of the knife's disk, (as it is wider at the front than at the rear end,) inasmuch as it commences cutting the straw first at the widest part, and gradually bringing its full length into operation, aids in producing this result; at the same time less power is required to operate the machine than if the knife's edge was horizontal, bringing its full cutting length on the straw at the same time. Except at its cutting-part, the knife is cased up with metal, thereby forming for the knife a deep groove, in which it acts; but for the cutting portion a shallow groove by which, as the straw passes under the knife, it is supported on both sides of the same, thus aiding in producing a clean and perfect cut of the straw.

For receiving and utilizing lost motion transmitted by the balance-wheel, there is at the end *e* of the arm *m* a slot, *t*. In the meantime one end of a spring, *p*, is attached to a lug, *g*, and the other to a stub, *v*, preventing the arm, before the knife reaches its terminal point from sliding on said lug. At this point the knife rests until by the rotation of the balance-wheel it is by the compound vertical and diagonal motion, as above described, carried into said groove, cutting the straw in its course into desired lengths.

The object of said lost motion is, without checking the machine, by the action of the feed-rolls *w'* and *w''* to gain time for feeding straw to the cutter.

A ready means for attaching and releasing

the knife, for grinding or other purposes, is provided in the flanged screws *u*. The relative dimensions of the wheels *T* and *l* are such that two strokes of the knife are made to one rotation of the crank.

To produce the requisite motion for feeding the straw to the cutter, the compound cam *a* is affixed to the shaft *C* on the outside of the frame, but inside of the wheel *T*. In its rotations said cam impinges on the shaft *v*, causing a vibratory motion to said shaft corresponding to the irregular periphery of the cam, at the same time the said shaft being held to the cam by the flat spring *n*, one end of which is attached to the inside of the bar *B*, and the other to the vibrating end of the shaft *v*, while the opposite end of the shaft is permanently attached to the bar *B* on the opposite side of the frame.

*R* is a rocker-shaft, whose journaled ends operate on suitable bearings inserted in the vertical inner sides of the bars *B*, contiguous to which bearings, and near the ends of said shaft, are solidly joined to the same the rocking posts *p'*, while extending to any desired distance below said shaft is the flat metal pendant *d*, its lower portion, for the purpose of regulating feed-motion to the rolls *w'* and *w''*, being perforated with more or less mortises for the toothed end of the arm *b*, the other end being attached to the vibrating end of the shaft *v*. At the top of these posts *p'*, by mortise and tenon, is affixed the pallet *l'*, working into and operating the ratchet-wheel *W* and driving the top feed-roll *w'*, while *l''* falls upon and drives the lower feed-roll *w''*, the one working into the under side of the ratchet-wheel *W*, and the other into the top of the ratchet-wheel on the other side of the frame. (Not shown.) For holding *l'* to its office its rear end is extended and weighted with lugs.

For the purpose of holding the top feed-roll to the straw in any quantity desired at any one time, the scroll-springs *s'* are attached to the sides of the box *F*, extending over the shaft of said roll, while, for preventing the rolls in their rotations from slipping over the straw without feeding it to the knife, there are longitudinally and radially inserted into the periphery of the rolls metal slips *c*.

Chiefly concealed in mortises in the inside face of the front corner-posts *P*, for securing

the pallet-motion to the rolls *w'* and *w''*, are pawls, producing by said ratchet-wheel a perfect operation of the rolls.

The operation of my invention is as follows: In rotating the crank-shaft *C* motion is communicated to the bevel-wheels *T* and *l*, which revolves the balance-wheel *w*, causing the knife, by the arm *m* and slots *o*, to make the drawing cut. In the meantime the cam *a*, through the vibrating shaft *v*, actuates the pallets *l'* and *l''*, by which the rolls feed the straw to the cutter. By adjusting the feed through the arm *b* and mortises in the pendant *d* the same is cut to any desired length.

Having described the construction and operation of my improvement in straw-cutters, what I claim as my invention, and for which I ask of the United States that Letters Patent may be granted unto me, is—

1. The arm *m*, having the slot *t*, sliding on the lug *g*, provided with the spring *p*, and connected to the balance-wheel by the stub-wrist *s*, in combination with the knife *N* and wheel *W*, for the purposes substantially as set forth.

2. The arm *m*, having the slot *t*, sliding on the lug *g*, provided with the spring *p*, and connected to the balance-wheel by the stub-wrist *s*, in combination with the crank-shaft *C*, crank *k*, gear-wheels *T* and *l*, as and for the purposes specified.

3. The compound cam *a*, vibrating shaft *v*, flat semicircular spring *w*, and toothed arm *b*, in combination with the rock-shaft *R*, oscillating posts *p'*, pallets *l'* *l''*, springs *s''*, with the feed-rolls *w'* *w''*, substantially as and for the purposes specified.

4. The rock-shaft *R*, provided with the rocking posts *p'* *p''* and mortised rocking pendant *d*, in combination with the pallets *l'* and *l''*, ratchet-wheels *W*, and pawls, substantially as and for the purposes specified.

5. The rock-shaft *R*, oscillating posts *p'*, pallets *l'* *l''*, springs *s''*, with the feed-rolls *w'* *w''*, substantially as and for the purposes specified.

In testimony whereof I have hereto, in presence of two witnesses, subscribed my name, in Rochester, New York, April 20, 1876.

LORENZO WINSLOW.

Witnesses:

JOHN HAY,  
JOHN THOMSON.