

M. V. DRAKE.  
 TURBINE WATER-WHEEL.

No. 187,833.

Patented Feb. 27, 1877.

Fig. 1.

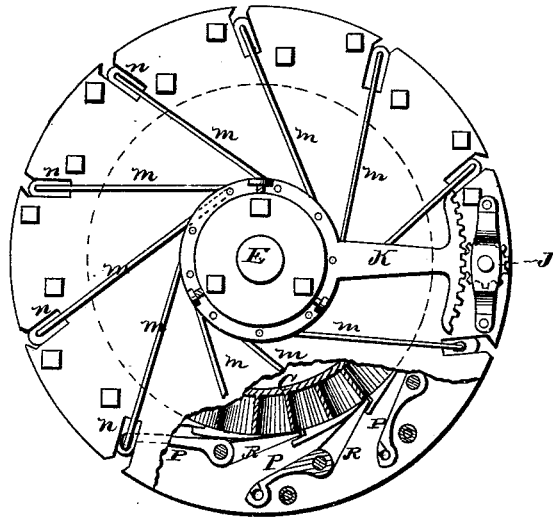

Fig. 2.

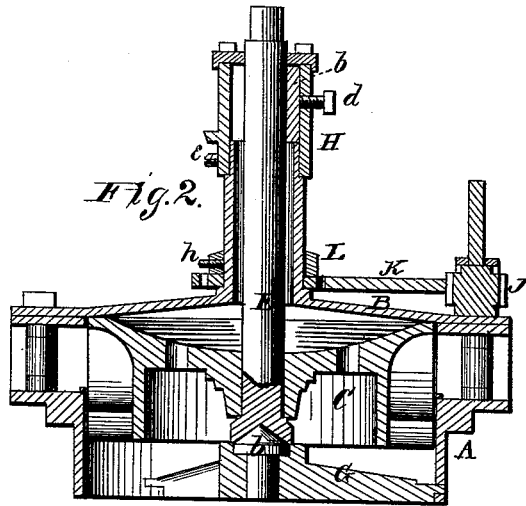

Fig. 3.

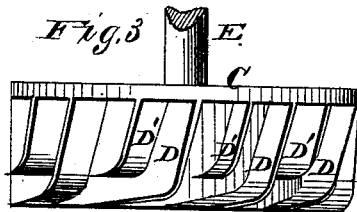
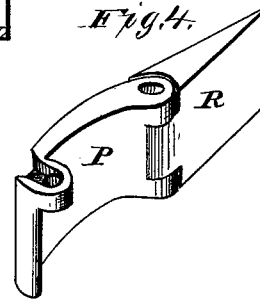

Fig. 4.



WITNESSES  
*F. L. Curands*  
*C. R. Sweet.*

INVENTOR  
*Merritt V. Drake*  
*Harold Mason*  
 ATTORNEYS

# UNITED STATES PATENT OFFICE.

MERRITT V. DRAKE, OF ATTICA, INDIANA, ASSIGNOR OF ONE-FOURTH OF HIS RIGHT TO NEWMAN PORTER FOSTER, OF SAME PLACE.

## IMPROVEMENT IN TURBINE WATER-WHEELS.

Specification forming part of Letters Patent No. 187,833, dated February 27, 1877; application filed December 13, 1876.

*To all whom it may concern:*

Be it known that I, MERRITT VANTILE DRAKE, of Attica, in the county of Fountain, and in the State of Indiana, have invented certain new and useful Improvements in Turbine Water-Wheels; and do hereby declare that the following is a full, clear, and exact description thereof, reference being had to the accompanying drawings, and to the letters of reference marked thereon, making a part of this specification.

The nature of my invention consists in the construction and arrangement of a turbine water-wheel, as will be hereinafter more fully set forth.

In order to enable others skilled in the art to which my invention appertains to make and use the same, I will now proceed to describe its construction and operation, referring to the annexed drawing, in which—

Figure 1 is a plan view of my water-wheel, with a part thereof in horizontal section. Fig. 2 is a vertical section of the same. Fig. 3 is a side elevation of the wheel proper, and Fig. 4 is an enlarged perspective view of one of the gates and chute.

The casing of my water-wheel is composed of a bottom part, A, and top part B, receiving between them the wheel C. This wheel is attached to a vertical shaft, E, and is provided on its circumference with a series of nearly L-shaped buckets, D D, and between these buckets are shorter buckets D' D', as shown, so as to form a circle of alternate long and short buckets. By this means greater power is obtained, while the exit of water remains large enough for all purposes. The lower end of the shaft E rests on a wooden step, b, which is inserted in the bridge-tree G, fastened to the lower part A of the casing. The shaft E

is further held by a box, H, which is fastened by a set-screw, e, to the neck I of the upper casing B. Within the box H are suitable wood blocks d, adjusted by means of set-screws f, for holding the shaft E in proper position. J is a pinion, for operating the rack-bar K, which encircles the neck I, and held thereon by means of a collar, L, fastened by means of a set-screw, h. The rack-bar K is provided with a circle of holes to receive a series of connecting-rods, m m, having hooks on both ends, the hooks on the inner ends being inserted from underneath in the holes on the rack-bar, while the hooks at the outer ends project down through slots n n in the upper casing B far enough to enter slots in the gates P for opening the same. These gates are placed between the two parts A B of the casing, and are attached, by suitable hinges, to stationary chutes R, as shown. The gates P close independent of each other, and are self-closing, so that if any drift-wood should get in any one or more of the gates the balance of the gates can close and stop the motion of the wheel. The two parts of the casing A B are held apart by suitable stands and bolts through the center of the same.

Having thus fully described my invention, what I claim as new, and desire to secure by Letters Patent, is—

The wheel C, provided with alternate long L shaped buckets D and short buckets D', substantially as herein set forth.

In testimony that I claim the foregoing I have hereunto set my hand this 22d day of November, 1876.

MERRITT VANTILE DRAKE.

Witnesses:

COLUMBUS NAVE,  
WILLIAM SLOAN.