

S. SAWYER.
MOLDING-MACHINES.

No. 187,914.

Patented Feb. 27, 1877.

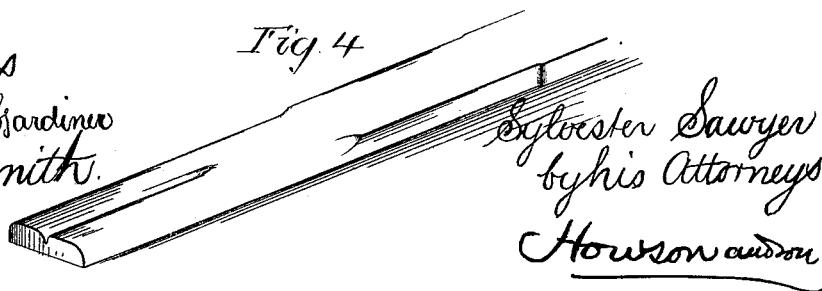
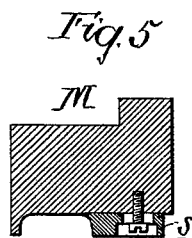
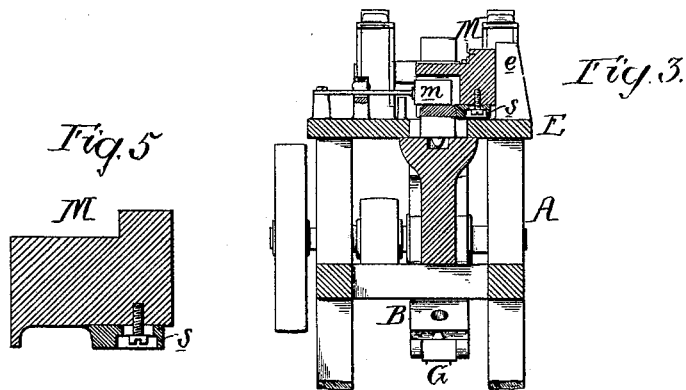
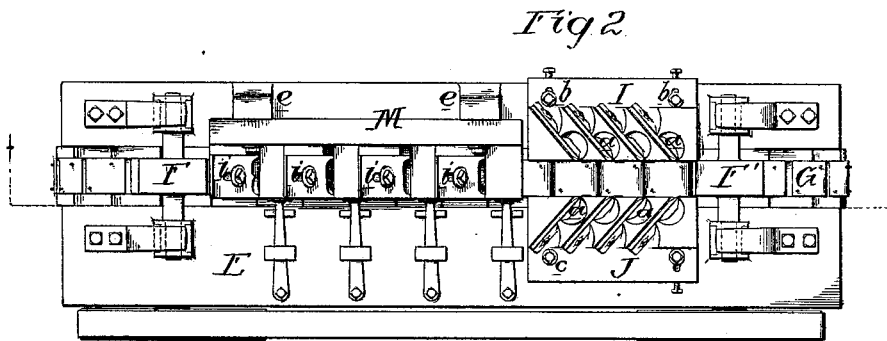
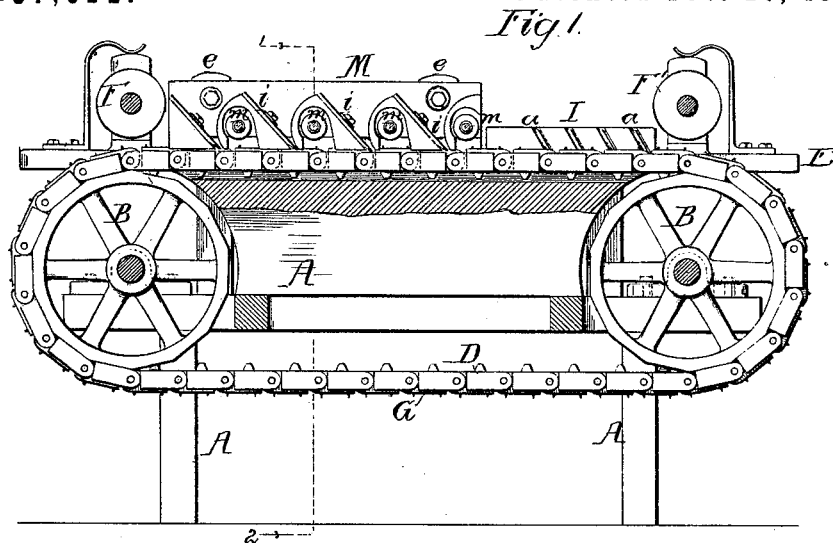

Witnesses
Richard L. Gardiner
Harry Smith.

Sylvester Sawyer
by his Attorneys
Howson and son

UNITED STATES PATENT OFFICE.

SYLVESTER SAWYER, OF PHILADELPHIA, PENNSYLVANIA.

IMPROVEMENT IN MOLDING-MACHINES.

Specification forming part of Letters Patent No. 187,914, dated February 27, 1877; application filed January 15, 1877.

To all whom it may concern :

Be it known that I, SYLVESTER SAWYER, of Philadelphia, Pennsylvania, have invented certain Improvements in Molding Machinery, of which the following is a specification:

My invention relates to certain improvements in that class of molding-machines in which the work is fed to stationary cutters; and the object of my invention is to improve the construction and increase the efficiency of machines of this class, an object which I attain in the manner hereinafter described, reference being had to the accompanying drawing, in which—

Figure 1 is a vertical sectional view of my improved molding-machine; Fig. 2, a plan view of the same; Fig. 3, a transverse vertical section on the line 1 2, Fig. 1; and Fig. 4, a perspective view, showing the successive operations upon the strip.

A is the frame-work of the machine, which carries at its opposite ends the bearings of two chain-wheels, B B, over which passes the endless chain D, the latter carrying a band, G, composed of a number of connected blocks, each provided with short spikes or pins, which penetrate the under side of the strip to be operated upon, traverse the strip on the table, and feed it to the stationary cutters. At opposite ends of the table E are bearings for yielding pressure-rollers F F', which bear upon the strip and press the same downward, so as to insure the proper penetration of the spikes of the endless band G. Adjacent to the roller F' are two horizontal plates, I and J, arranged one on each side of the band G, and resting on the table E, each of these plates carrying a number of cutters, a, four on each side being shown in the present instance. The plate I is secured to the table E by set-screws b, which pass through slots in the plate, so that the latter can be adjusted laterally and secured after adjustment. The plate J is hung at the front end to a fixed pin, c, but is slotted at the rear end, and can thus be set at any desired angle in respect to the band G, so that although the cutters at the front ends of the plates I and J are always at the proper distance apart, the distance between the cutters gradually increases toward the rear end; hence the shaving of the sides of the strip is gradual, and inequalities in the

width of the same are more readily overcome. Between the plates I and J and the roller F intervenes a frame, M, which is directly over the band G, and is carried by posts e e on the table E. The frame M carries four cutters, i, the lower edges of which act on the upper face of the strip as it is drawn beneath them, the edges of the cutters i being of such a shape as to impart the desired form to the upper face of the strip. The portions of the frame M between the cutters are recessed for the reception of yielding pressure-rollers m, which serve to hold the strip firmly in contact with the spikes on the endless band G, and those portions of the frame before and behind the rollers extend down over the top and outer edge of the strip, as shown in Fig. 5, and thus serve to prevent the cutters from lifting the strip clear of the pins. The inner edge of the strip is held and guided by the grooved face of the strip s, adapted to the under side of the frame M, and rendered adjustable laterally to suit strips of different widths.

The above-described machine is adapted to operate upon strips of various widths, and can operate at a high rate of speed with less danger of injury to the material or to the cutters than in machines of this class as usually constructed.

I am aware that it is old to employ adjustable cutter-plates in molding-machines. This I do not desire to claim, broadly; but

I claim as my invention—

1. The combination of the feeding-band G, with the cutter-plate J hinged at one end, and laterally adjustable at the other, as described.

2. The combination of the frame M and its cutters i, with the laterally-adjustable pressure-strip s, as specified.

3. The combination of the longitudinally-traversing-band G, the laterally-adjustable cutter-plate I, and the frame M with its laterally-adjustable pressure-strip s, as set forth.

In testimony whereof I have signed my name to this specification in the presence of two subscribing witnesses.

SYLVESTER SAWYER.

Witnesses:

HERMANN MOESSNER,
HARRY SMITH.