

L. B. FLANDERS.

MACHINE FOR TURNING LOCOMOTIVE CRANK-PINS.

No. 188,008.

Patented March 6, 1877.

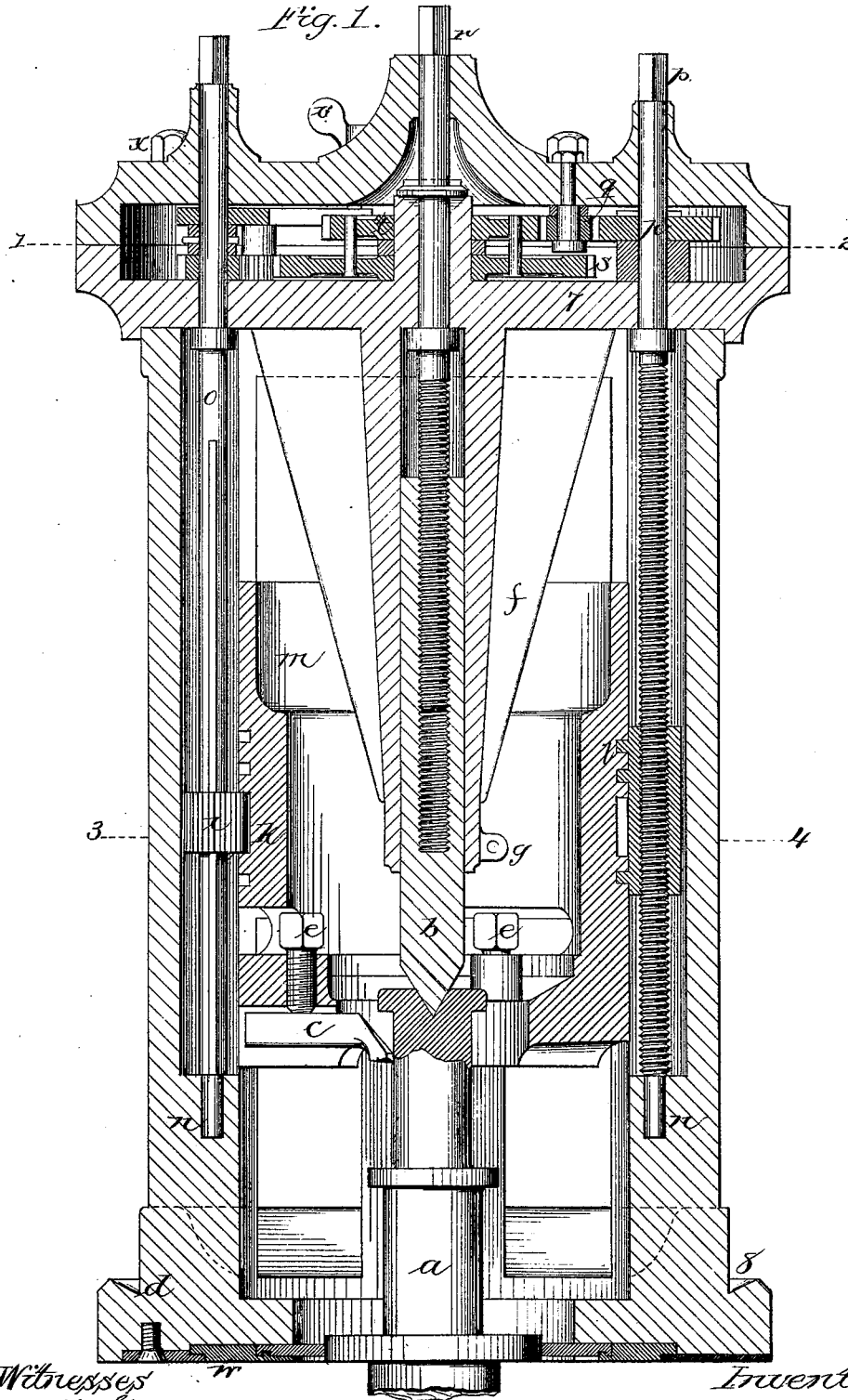

Witnesses
J. Shaw
Wm. Barwood

Inventor:
L. B. Flanders.

L. B. FLANDERS.

MACHINE FOR TURNING LOCOMOTIVE CRANK-PINS.

No. 188,008.

Patented March 6, 1877.

Fig. 2.

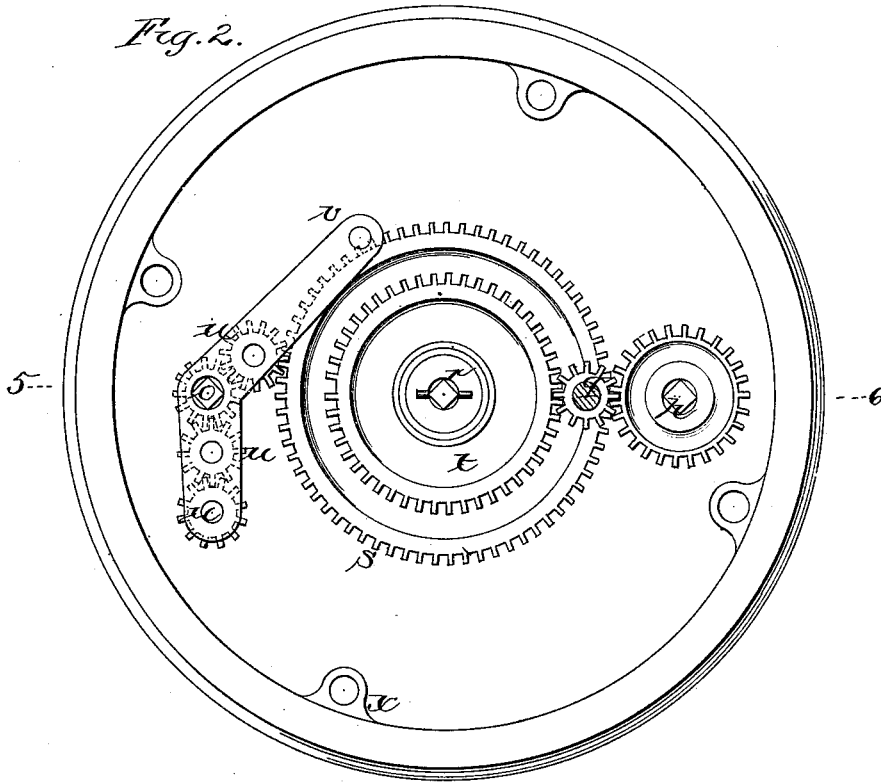
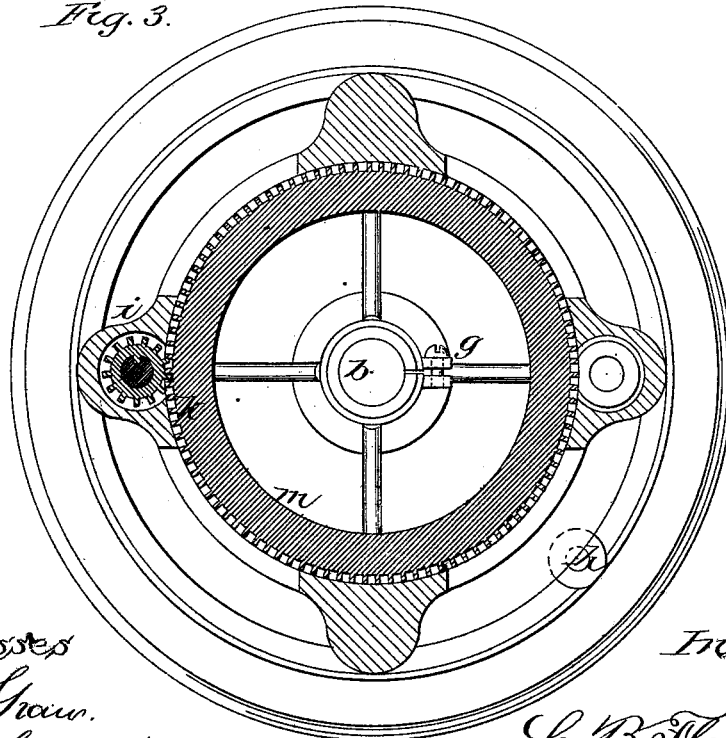

Fig. 3.



Witnesses
J. Shaw.
Wm. Garwood

Inventor
L. B. Flanders

L. B. FLANDERS.

MACHINE FOR TURNING LOCOMOTIVE CRANK-PINS.

No. 188,008.

Patented March 6, 1877.

Fig. 4.

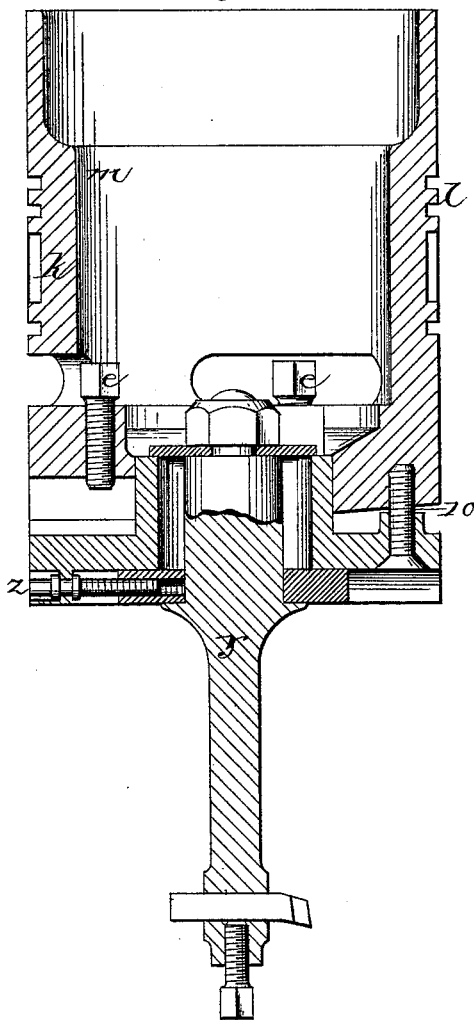
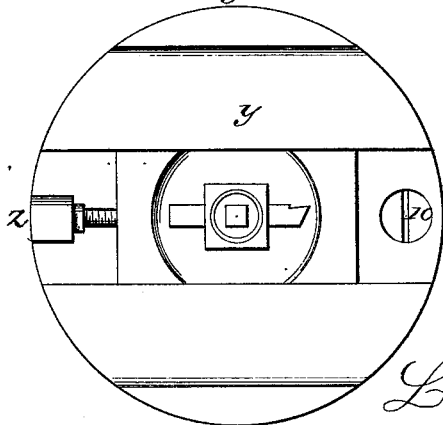

Fig. 5.



Witnesses
J. Shaw
Wm. Garwood

Inventor
L. B. Flanders

UNITED STATES PATENT OFFICE.

LUCIAN B. FLANDERS, OF PHILADELPHIA, PENNSYLVANIA.

IMPROVEMENT IN MACHINES FOR TURNING LOCOMOTIVE CRANK-PINS.

Specification forming part of Letters Patent No. **188,008**, dated March 6, 1877; application filed July 3, 1876.

To all whom it may concern:

Be it known that I, LUCIAN B. FLANDERS, of the city and county of Philadelphia, Pennsylvania, have invented a new and Improved Crank-Pin Turning and Wheel-Boring Machine; and I hereby declare the following to be a full, clear, and exact description of the same, reference being had to the accompanying drawings, and to the letters of reference marked thereon.

My invention relates to the rotating tool-carrying cylinder, and the mode of rotating and feeding the same, and to the method of securing the same in position, and to the manner of securing the cutting or boring tool, and to devices for securing the center, as hereinafter described.

The object of the invention is to enable the construction and operation of a secure, firm, and compact machine for turning crank-pins and for boring holes for crank-pins, and any other purpose where said machine can bore or turn to advantage.

In order to enable others to use and practice my invention, I will proceed to describe its construction and operation.

On reference to the accompanying drawings, which form part of the specification, Figure 1 is a vertical section across lines 5 and 6 of Fig. 2, through the center of the machine; Fig. 2, a top view with the cover removed, across lines 1 and 2 of Fig. 1; Fig. 3, a top view across lines 3 and 4 of Fig. 1; Fig. 4, a vertical section through the center of the tool-carrying cylinder, with the boring-tool in position; and Fig. 5, a bottom view of the boring-tool post *y*.

Similar letters refer to similar parts throughout the several views.

d, Fig. 1, is a heavy cast-metal ring, projecting from which are four columns, *n*, the said columns being secured at their upper ends to the cap-plate 7. The inner walls of the columns *n* are bored true for the reception of the tool-carrying cylinder *m*, which has bearing against the said inner walls of the columns. One of these columns is bored for the reception of the feed-screw *p* and its nut *l*. The projections on the nut *l* enter the grooves on the periphery of the cylinder *m*, for the purpose of giving longitudinal motion to said cylinder by

means of said feed-screw *p*. One of the said columns *n* is bored for the reception of the operating-shaft *o*, which shaft is provided with a key or feather for the purpose of rotating the pinion *i*, which meshes with spur-teeth formed around the periphery of the cylinder *m*, by means of which said cylinder is rotated, the power being applied by hand or otherwise to the outer end of the shaft *o*. *a* is an ordinary locomotive crank-pin, fitted in position for turning, and it is secured in concentric position by ordinary chuck-jaws *w*, operated by ordinary spiral cam-grooves, the machine being secured firmly to the crank-wheel by clamps interlocking in dovetail grooves 8 of the ring *d*, and secured firmly by bolts to the crank-wheel. The center *b* is held securely in its cast frame *f*, which is suspended from the cap 7, and insures the concentric location of the machine and aids in detecting the bent crank-pins. The center *b* is operated by the screw *r*, by crank-wrench applied at its outer end, and is secured against loss of motion by the split hub of the frame *f* with its tightening-screw *g*. *c* is the cutting-tool, held securely in position by the screw *e* forcing said tool down upon the tapering sides of the tool-chamber in the cylinder. The tapering sides of the tool-chamber prevent all chatter, and secure the tool from twisting out of position.

The feed of the cutting-tool and of the cylinder *m* is rendered automatic by gearing from the shaft *o* to the screw *p*, as shown in Fig. 2. The pinion on the shaft *o* gears into loose pinions *u u u*, the journals of which are located in the vibrating arm *v*, operated by the thumb-screw *v'*, Fig. 1, the shaft of which works in a slot cut in the cover-plate. The vibration of the arm *v* throws either one of the outer pinions *u* into gear with the spur-wheel *s*, giving a movement forward or backward, according as either of said outer pinions *u* is thrown in or out of gear. There is also an intermediate point where both pinions are out of gear, permitting a free movement of feed-screw *p*, by hand, by crank-wrench on its outer end. The spur-wheels *s*, *t*, and *q* communicate motion from the shaft *o* and pinions *u* to the feed-screw pinion *p*. Screws and lugs *x* secure the upper head-cap in position. The boring attachment *y*, Fig. 5, is secured to the

tool-carrying cylinder *m* by bolts or screws 10. The tool-post is slotted for the reception of the cutter on its outer end, which cutter is secured by an ordinary screw. The base of the said tool-post terminates in a dovetailed plate, which is caused to traverse across the face end of the cylinder *m* upon its plate *y*, Fig. 5, and is controlled by the feed-screw *z*.

The machine is operated in this wise, after being secured to the crank-pin wheel by the chuck-jaws *w* and clamps resting on grooves 8, Fig. 1: The center *b* is caused to enter the center hole in the end of the crank-pin, which, if not bent, will come true, because of the face of the ring *d* and the bearing on the wheel being true surfaces; but if the crank-pin be bent the center *b* will detect the same, and will show where a new center-hole should be located concentric with the collar of the crank-pin at the base. After the center *b* enters the true center-hole in the crank-pin the machine is ready to turn the crank-pin by inserting the tool *c* in a proper cutting position, when the tool is rotated around the crank-pin by revolving the cylinder *m* by turning the power-shaft *o*, as described. The feed motion is thrown into gear by the thumb-screw *v'*, when the cut can be taken continuously from one end of the crank-pin to the other, the tool *c* being caused to take additional cuts by slight raps of a hammer on its outer end. Provisions are made for three cutters, all of which can be operated at one time, if desired.

The boring is conducted in the same manner as the turning, only requiring the substitution of the boring-tool post, as shown in Figs. 4 and 5. The cutter is secured firmly in position, and the feed for the enlargement of the hole is made by feed-screw *z*. The feed of the cylinder *m* is operated automatically by the screw *p* the same as when the device is employed for turning purposes.

It will be evident that the several parts of this invention can be considerably modified without any alteration in the result.

What I claim, and desire to secure by Letters Patent, is—

1. The combination, with the frame, consisting of the base-plate, columns, and cap, of the cylinder *m*, substantially as shown and described.

2. The combination with the frame, consisting of the base-plate, columns, and cap, of the cylinder *m*, and the boring or turning tool, substantially as and for the purpose set forth.

3. The center *b*, in combination with framing *f*, tightening-screw *g*, and screw *r*, as specified.

4. The arrangement of feed-gearing *o*, *u*, *s*, *t*, *q*, and *p*, in combination with screw *p*, nut *l*, and cylinder *m*, as specified.

L. B. FLANDERS.

Witnesses:

WM. GARWOOD,
T. SHAW.