

T. McFEELY.

MILLSTONE DRESSING MACHINE.

No. 188,022.

Patented March 6, 1877.

Fig. 1

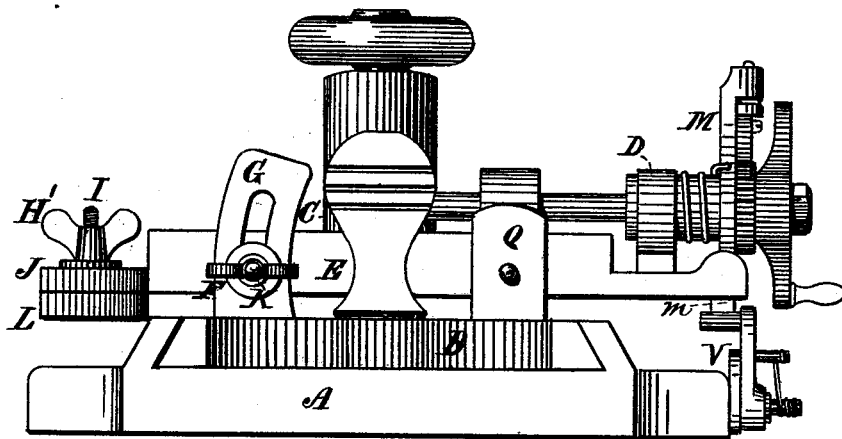
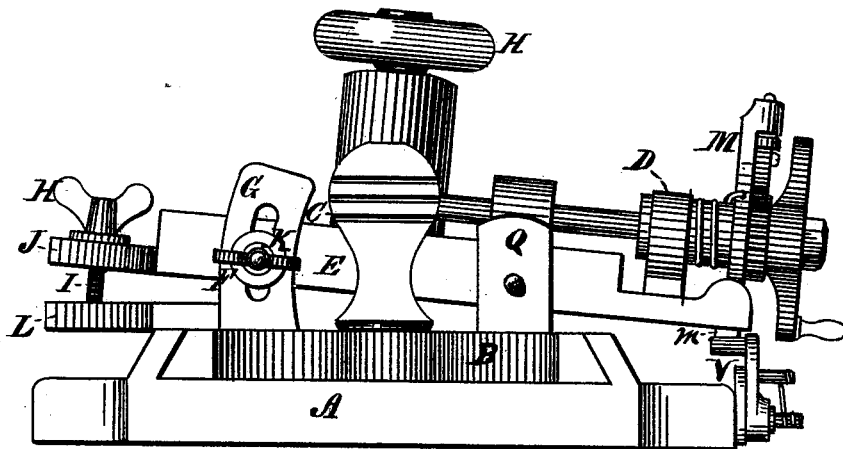

Fig. 2



Witnesses

W. F. Wright
W. C. Strawbridge

Thomas McFeely

Inventor

Bonsall Taylor

Attorney

T. McFEELY.

MILLSTONE DRESSING MACHINE.

No. 188,022.

Patented March 6, 1877.

Fig. 3.

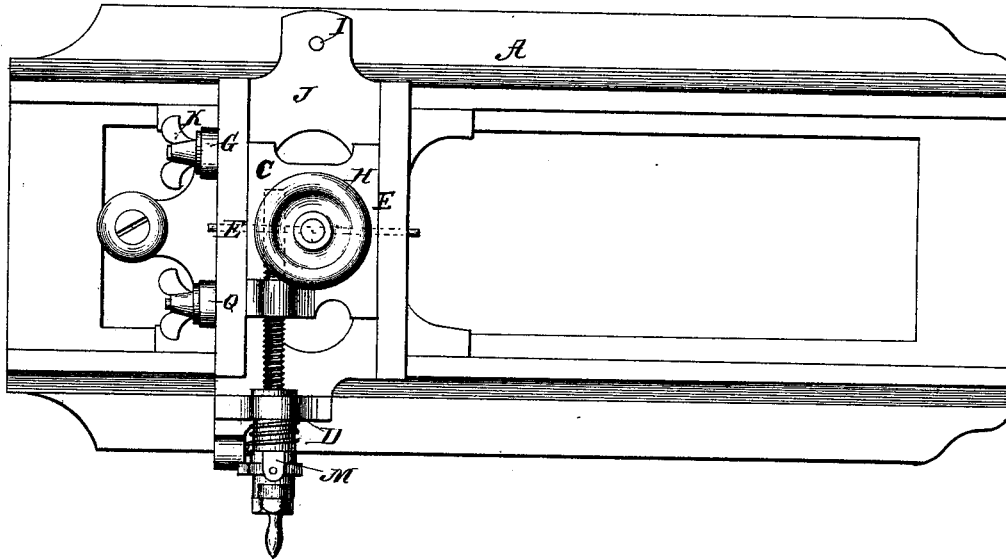

Witnesses.

W. G. Wright
W. C. Strawbridge

Inventor.

Thomas McFeely
Monsall Taylor
Atty

UNITED STATES PATENT OFFICE.

THOMAS McFEELY, OF MARION, INDIANA, ASSIGNOR TO SAMUEL E. GRISCOM,
OF POTTSVILLE, PENNSYLVANIA.

IMPROVEMENT IN MILLSTONE-DRESSING MACHINES.

Specification forming part of Letters Patent No. **188,022**, dated March 6, 1877; application filed
July 10, 1876.

To all whom it may concern:

Be it known that I, THOMAS McFEELY, of Marion, Grant county, Indiana, have invented a new and useful Improvement in Millstone-Dressing Machines; and I do hereby declare the following to be a full, clear, and precise description of the same, and such as will enable others skilled in the art to which it appertains to construct and employ my said improvement, reference being had to the accompanying drawing, forming part of this specification, and of which—

Figure 1 is an end elevation of my improved machine in position for dressing the land, and Fig. 2 a similar view of the same, but in position for dressing the furrows; Fig. 3, a plan showing a modified form of machine.

Similar letters of reference indicate corresponding parts wherever used.

This invention is an improvement upon Letters Patent No. 144,851, granted upon the 25th day of November, A. D. 1873, to Larer & Griscom for diamond millstone-dressing machines, but is applicable to any machine of the same class, which operates in a similar manner; and has for its object such a construction of the bit-supporting carriage as will permit of its easy adjustment for the cutting of furrows, to which end it consists in the devices hereinafter described and claimed.

A in the drawing represents the bed-plate of the machine; B, the longitudinally-sliding frame; C, the transversely-sliding carriage, which carries the cutting-tool.

In the Larer machine the carriage reciprocates in transverse guides, which form a part of or are rigidly attached to the longitudinally-sliding frame, such construction rendering it impossible to dress furrows without setting up the cutter by the hand-wheel H at the end of each longitudinal stroke.

To obviate this objection I form a separate bed, D, for the carriage, upon the sides of which bed are formed the carriage-guides E, and upon one end is placed the mechanism which actuates the carriage in its transverse throw. This bed is pivoted at one side between two ears, Q, formed on the frame B, and at the other is controlled by thumb-nuts

F, threaded upon screws K affixed to and laterally projecting from the bed D, and bearing, when tightened up, against curved slot standards G set upon the frame B to hold the bed D at any desired inclination, while at the end opposite to that supporting the actuating mechanism it is controlled by a thumb-nut, H', threaded upon an upright screw, I, which is secured to a projecting ear, L, upon the frame B, and which, when tightened, bears down upon a projecting ear, J, of the bed D.

From this arrangement of parts it is obvious that when the thumb-nuts F and H are loosened the carriage-bed D can be tilted to an angle correspondent to the inclination of the furrow to be dressed, and then set firmly to such angle by tightening up said nuts.

Upon reciprocation of the sliding frame B the carriage C will travel, accordingly as the machine may be set, up or down the incline of its bed D, and the bit score stroke by stroke up or down the furrow in a series of longitudinal lines, so as to dress it evenly throughout.

When the inclination is considerable it may be necessary to make the toe *m* of the rocker M adjustable in its length, so as to invariably encounter the latches V, whatever the approximately vertical position of the toe may be.

It is also obvious that, with the necessary mechanical changes in detail of construction, the bed D may be pivoted centrally, and be provided with a double set of standards, thumb-screws, and the like, and consequently be adapted to cut furrows inclined in either direction without transposing the machine, as represented in Fig. 3.

The improved machine is, of course, equally well fitted to dress the land or any level surface.

Having thus described my invention, I claim, and desire to secure by Letters Patent of the United States—

1. The carriage-bed D, pivoted to the sliding frame B, and adapted to be inclined with respect to the same, for dressing furrows, substantially as described.

2. As a means of adjusting the inclination

of the pivoted bed D with respect to the sliding frame B, the thumb-screws F K and standards G, and the thumb-screws H' I, and ears J L, arranged substantially as specified.

3. In combination with a pivoted carriage-bed, D, the carriage C, reciprocating in guides E on said carriage-bed, and the actuating mechanism, both carriage and mechanism being adapted to rock with the bed, substantially as described.

In testimony whereof I have hereunto signed my name in the presence of two subscribing witnesses.

THOS. McFEELY.

Witnesses:

J. BONSALE TAYLOR,
WALTER GRISCOM.