

G. H. NYE.

VALVES FOR STEAM VACUUM PUMPS.

No. 188,067.

Patented March 6, 1877.

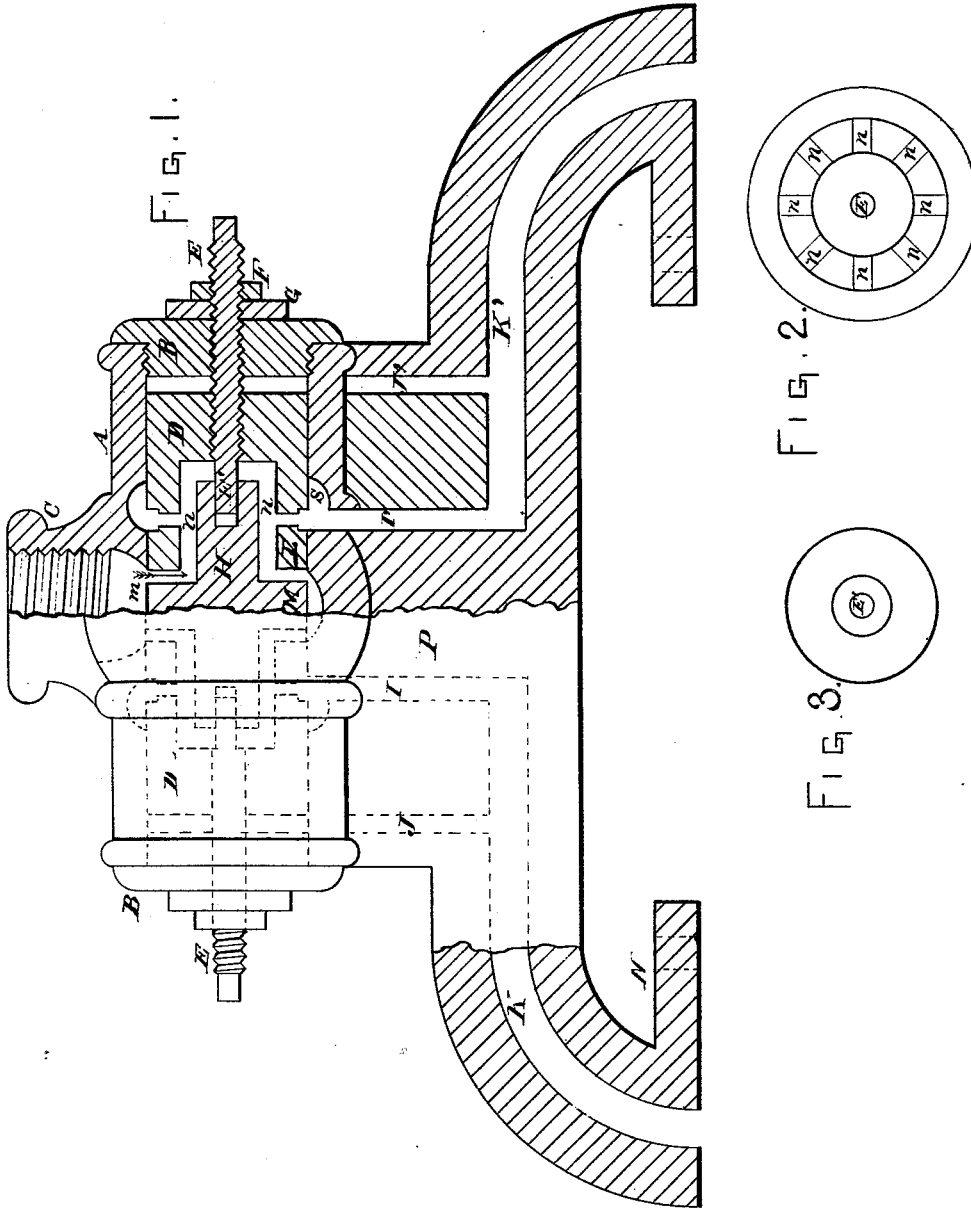

ATTEST:
O. H. Adix
Joseph Arkins

INVENTOR:
George H. Nye
By J. A. Chapin
Atty.

UNITED STATES PATENT OFFICE.

GEORGE H. NYE, OF CHICAGO, ILLINOIS.

IMPROVEMENT IN VALVES FOR STEAM VACUUM-PUMPS.

Specification forming part of Letters Patent No. 188,067, dated March 6, 1877; application filed February 8, 1877.

To all whom it may concern:

Be it known that I, GEORGE H. NYE, of Chicago, in the county of Cook and State of Illinois, have invented a new and useful Improvement in Valves for Steam Vacuum-Pumps, of which the following is a specification:

The nature of the present invention consists in a valve whose stems are arranged to slide on the ends of screw-rods, by means of which adjustable cups are to be brought to or from the valve, so as to contract or enlarge the steam-ports, as may be required, in the use of different pressures of steam, or raising columns of water to different heights.

The object of the invention is to provide a valve which shall be more generally applicable to all purposes as used, instead of the valve patented to me December 15, 1874, on the same pump.

In the drawings, Figure 1 is a longitudinal semi-section and semi-elevation of my improvement complete as it is to be attached to the vacuum-cylinders of the pump in the patent referred to; Fig. 2, an end elevation of the valve; and Fig. 3, an end view of one of the cups, looking into the chambered end thereof.

A represents a cast-metal case, of such size as may be required to receive steam enough to force the water out of the cylinders below at a desired speed, a case eight inches long being found sufficient for vacuum-cylinders having a capacity of about one hundred gallons. This case is provided with an ordinary pipe-connection, C, for receiving the steam-pipe connecting with a steam-boiler of suitable capacity, and it is cast solid to a stand, P, which, by means of flange-seats N N, is to be attached securely to vacuum-cylinders below, as shown in the patent cited, and it is bored out inside, to receive a valve, M, and closely-fitting cups D. These cups are rigidly attached to screw-rods E, projecting through the cylinder-heads B, as shown at Fig. 1, so that, by turning the rods by a wrench from the outside of the case or cylinder A, the ports *m* between the inner ends of the cups and the valve M may be increased or diminished. The ends E', projecting into the chambers of the cups, pass into bearings

formed in the stems H of the valve M, and hold the latter in place to have a true and free longitudinal reciprocating movement between the cups D D. Jam-nuts G F are placed on the screw-rods E, at the outside of the heads B, that the cups D, when adjusted, may not get out of position; and on the internal periphery of the case A are formed annular grooves or channels S, that steam entering the cups D may pass through a series of ports, *n*, in the cup, and through ports I I' and ports K K' into the cylinders below. A port, J, through the stand P, at either end, admits steam to the back ends of the cups D, to obviate the steam-pressure on their inner ends.

The operation is as follows: Steam enters pipe C—as, for instance, under a pressure of fifty pounds per square inch, to raise water one hundred feet high—the cylinder under port K' being full of water, and the steam passing through ports *m n J' K'*, the water will be forced down and out at the bottom of said cylinder. When this is done the steam following the water, as in said patent, reduces the pressure in the cylinder under port K', at which time the increased velocity of steam, caused now by a partial vacuum, will shut the port *m*, by moving the valve M against the cup at L. The port *m* now being closed, the port at the opposite end of the valve M is opened, and steam passing through it drives water out of cylinder under port K while the cylinder-port K' is refilling. By a continuous alternate force of steam on the body of water in the cylinders below the ports K K', respectively, a constant flow of water is driven through a discharge-pipe at the bottoms of said cylinders, the movement of valve M being automatic.

For using twenty-five pounds of steam, the ports *m* should, by means of the adjusting-rods E, be opened, so as to have about one-third more area; but the ports may have any area of opening to meet the requirements, as when water is to be raised to different heights and different sized cylinders are used. By this means I am enabled to adjust the valve M to any desired pressure of steam, and to raise water so high as steam will force it, and to use steam more economically than by fixed

valves, and also save much time in the adjustment, and elevate a more uniform stream of water. Instead of the valve M a ball-valve may be placed between the cups D D, and serve a good purpose, dispensing with the bearings formed by the inner ends of the screw-rods.

I claim and desire to secure by Letters Patent—

1. The cups D D, in combination with the adjusting screw-rods E, case A, stand P, and

a reciprocating valve between the cups, as and for the purpose set forth.

2. The combination of the valve M, adjustable cups D, screw-rods F, and ports *m n* J K K' with case A and stand P, as and for the purpose specified.

GEORGE H. NYE.

Witnesses:

O. H. ADIX,
G. L. CHAPIN.