

C. H. POND.

SIGNAL-BOXES FOR FIRE-ALARM TELEGRAPHS.

No. 188,182.

Patented March 6, 1377.

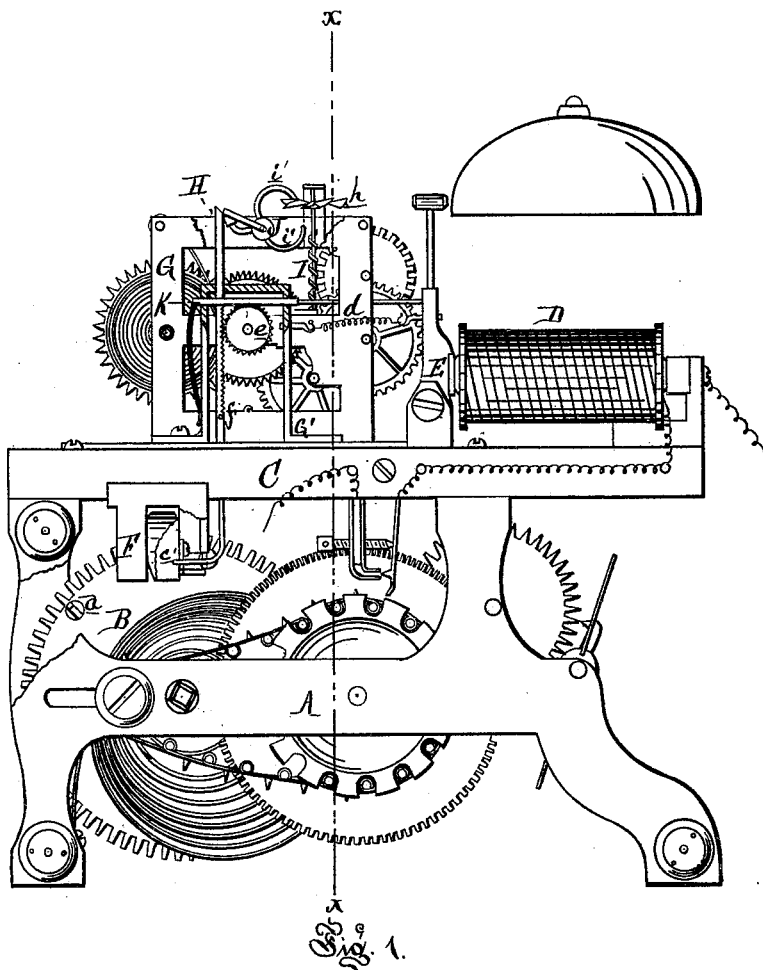

Witness:  
A. B. Allen  
R. X. Lombard

Inventor:  
C. H. Pond  
By Atty  
John S. Sprague

C. H. POND.

SIGNAL-BOXES FOR FIRE-ALARM TELEGRAPHS.

No. 188,182.

Patented March 6, 1877.

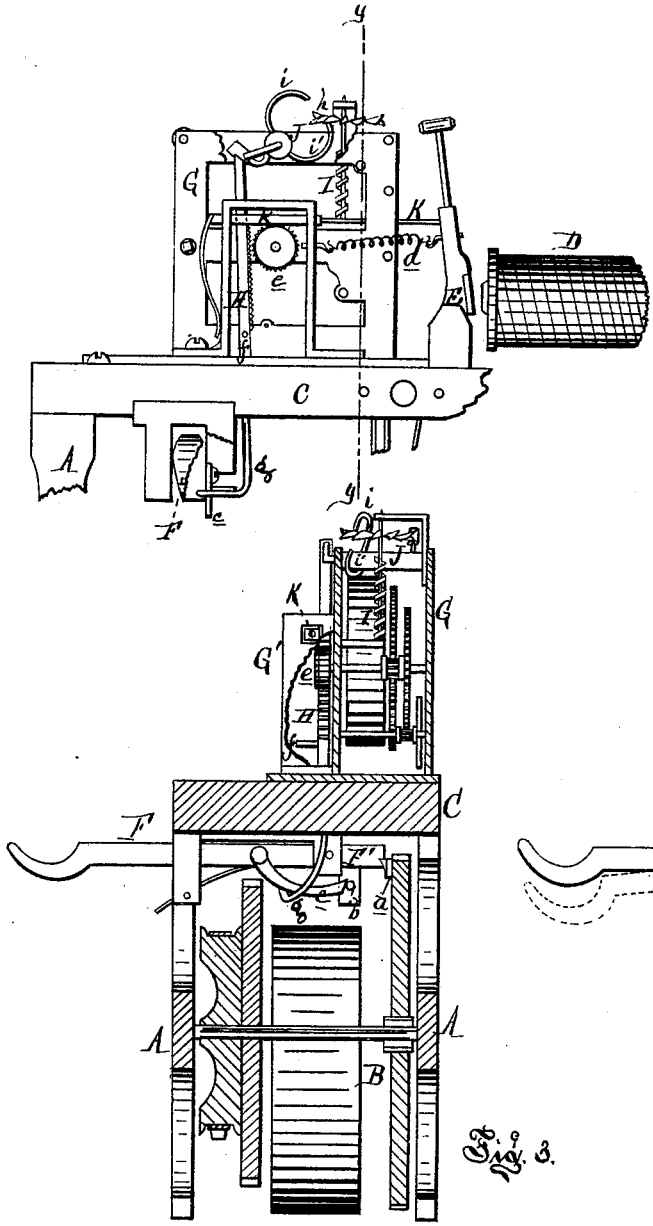

Fig. 2.

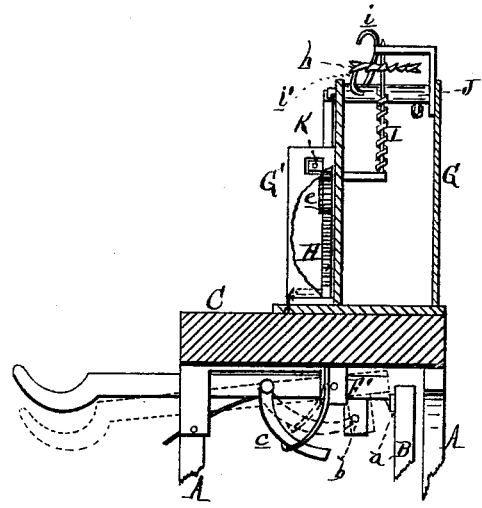

Fig. 4.

Fig. 3.

Attest:  
 H. B. Aulls  
 R. X. Combs

Inventor:  
 C. H. Pond  
 By Atty  
 Phil S. Sprague

# UNITED STATES PATENT OFFICE.

CHESTER H. POND, OF JACKSON, MICHIGAN, ASSIGNOR TO THE MICHIGAN FIRE ALARM COMPANY, OF SAME PLACE.

## IMPROVEMENT IN SIGNAL-BOXES FOR FIRE-ALARM TELEGRAPHS.

Specification forming part of Letters Patent No. 188,182, dated March 6, 1877; application filed February 19, 1877.

*To all whom it may concern:*

Be it known that I, CHESTER H. POND, of Jackson, in the county of Jackson, and State of Michigan, have invented an Improvement in Signal-Boxes for Fire-Alarm Telegraphs, of which the following is a specification:

The nature of my invention relates to an improvement in electro-magnetic signal-boxes, such as are used in municipal fire-alarm-telegraph systems. As is well known to electricians, firemen, and others, great confusion and loss of much valuable time occur when it happens that signals are simultaneously sent in from different boxes.

The object I have in view is to provide each signal-box with what may be termed a "non-interfering attachment," which, when any one box is "pulled," will render it impossible to send signals from all other boxes in circuit until said box has ceased to give signals.

The invention consists, mainly, in a jointed detent-lever and dog, so arranged that the detent cannot be withdrawn from the stop of the going-barrel of the box until said dog is raised to come in contact with the detent, and, in combination therewith, a spring-actuated mechanism controlled by a magnet in the main circuit, which will raise and keep raised said dog so long as the circuit is closed, but will drop it as soon as the circuit is broken, and thus render it impossible to withdraw the detent from the going-barrel of the box.

Figure 1 is a front elevation, partially in section, of the signal-box mechanism and its attachment, the several parts being in their relative positions, as when the circuit is closed. Fig. 2 is a similar view, showing the positions of the parts as when the circuit is broken in sending signals. Fig. 3 is a cross-section at *x x*, in Fig. 1. Fig. 4 is a similar section at *y y*, in the second figure.

In the drawing, A represents the frame, in which the various shafts and arbors of the signal-sending train are journaled, of which the going-barrel B is provided with one or more stops, *a*, as shown. The construction and operation of the signal-sending mechanism being well understood, it is not necessary to describe the same, except to state that by

withdrawing a detent from the stop *a* in "pulling" the box the going-wheel B will be rotated by the mainspring, and thus actuate the circuit-breakers. C is a base-board resting on the frame, and on it is placed the magnet D in the main circuit, and of which E is the armature, whose lever carries a hammer for sounding the signals on a bell in the box. F is the pulling-lever, which is not, as heretofore, a detent that arrests the wheel B by coming into the path of the stops *a*, but is jointed, and, with its inner continuation or detent proper F', is pivoted in hangers, pendent from the under surface of the board C. The part F' is cast with a pendent lug having a lateral projection, *b*, at the foot. *c* is a curved dog, pivoted to the side of the lever F, near the inner end thereof, and, when swung up so that its free end comes against the projection *b*, the detent F' can be raised out of the path of the stop *a*, when the lever F is depressed, but otherwise the latter will not act upon the detent, and no signal can be given or sent if said lever be pulled down. G is the framework of the non-interfering attachment, mounted on the base C, and in front of it is a smaller one, G', to which the armature-spring *d* is attached.

The frame G contains a train of spring-driven gearing, on one arbor of which, projecting to the front, there is a pinion, *e*, with which may engage a toothed rack-bar, H, passing through slots in the top and bottom of the frame G', but arrested in its descent by a pin, *f*. At its lower end is a hook, *g*, which comes under the dog *c* to lift it into contact with the projection *b* of the detent, when said bar H is raised for that purpose. In the frame G there is a vertical worm-shaft, I, carrying an Archimedean fly *h*. J is a rock-shaft, journaled in the top of said frame, carrying two curved stops, *i i'*, the former having its end above, and the latter its end below, the fly, the shaft J being weighted by an arm, *j*, so as to throw up the latter against the fly, when not otherwise prevented, and stop the motion of the train. Either stop, when brought against the fly, will arrest the motion of the train. K is a bar, horizontally secured to the armature-lever, and plays with it in guide-

slots in the upper part of the frame  $G'$ , inside of which it is slotted to receive the rack-bar  $H$ , which it moves back and forth.

As soon as the circuit is closed the armature, being attached to the magnet, draws the rack-bar forward into gear with the pinion  $e$ . At the same time the beveled head of said bar  $H$ , passing under the arm  $J$ , raises it, thereby removing the stop  $i'$  from the fly, which permits the train to be set in motion by its spring. The rack-bar  $H$  is elevated in the rotation of the pinion  $e$  until the stop  $i$ , coming into contact with the fly, stops the motion of said train, said rack-bar and its hook  $g$  raising the dog  $c$  into contact with the projection  $b$  of the detent  $F'$ . This is the normal condition of every signal-box in a closed circuit, the dog  $c$  being in position to withdraw the detent on pressing down the lever  $F$  to send in an alarm from any box.

The circuit being broken in giving a signal from any box, the rack-bar  $H$  in every box is carried back out of mesh from its pinion, and consequently drops, allowing the dog to fall below the projection  $b$  of the detent; consequently no pull-lever can again actuate its

detent until the circuit has been again closed and the rack-bar of each box is run up to its normal position. It will then be seen that, from the commencement of the giving of an alarm from any box until the completion of the same, no other box in the circuit can be pulled.

What I claim as my invention is—

In a fire alarm-telegraph signal-box, substantially as described, the combination of the following elements, to wit: a detent for the going-barrel or main wheel of the circuit-breaking train; a lever with a pivoted dog adapted to release said detent from the said wheel only when raised into contact with the detent, a rack-bar, arranged to raise said dog, and to be raised and sustained by a pinion of a spring-driven train; and a connection with the armature of the local magnet that will throw said rack-bar into or out of gear with said pinion as the circuit is closed or opened, substantially as and for the purpose set forth.

CHESTER H. POND.

Witnesses:

H. F. EBERTS,  
H. S. SPRAGUE.