

A. J. STOTT.
HYDRAULIC ENGINE.

No. 188,203.

Patented March 6, 1877.

Fig. 1.

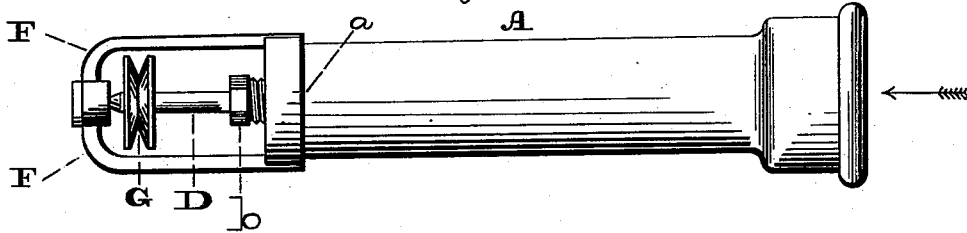

Fig. 2.

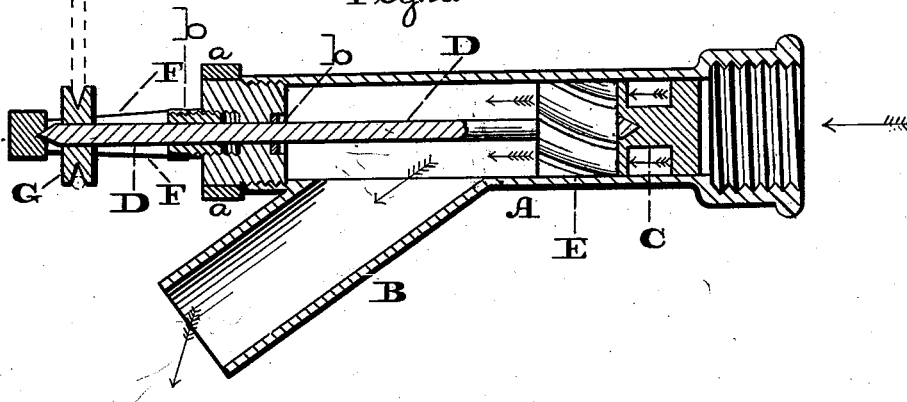

Fig. 4.

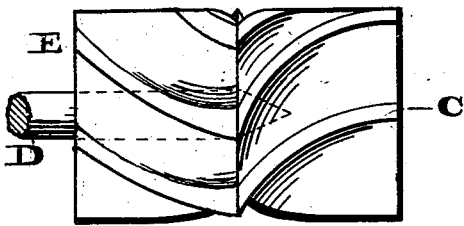

Fig. 5.

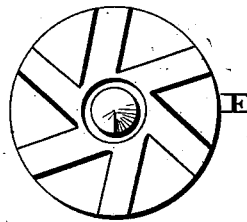
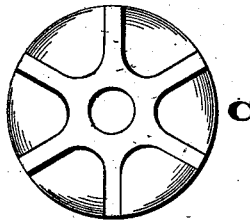

Fig. 3.



Witnesses:

Lewis C. Brown.
R. P. Grant.

Inventor:

Asa J. Stott.

John A. Gieseler
Attorney.

UNITED STATES PATENT OFFICE.

ASA J. STOTT, OF PHILADELPHIA, PENNSYLVANIA, ASSIGNOR OF ONE-HALF OF HIS RIGHT TO JOHN FLETCHER, OF MANCHESTER, ENGLAND.

IMPROVEMENT IN HYDRAULIC ENGINES.

Specification forming part of Letters Patent No. **188,203**, dated March 6, 1877; application filed October 30, 1876.

To all whom it may concern:

Be it known that I, ASA J. STOTT, of the city and county of Philadelphia, and State of Pennsylvania, have invented a new and useful Improvement in Water-Wheels; and I do hereby declare the following to be a clear and exact description of the nature thereof, sufficient to enable others skilled in the art to which my invention appertains to fully understand, make, and use the same, reference being had to the accompanying drawings, making part of this specification, in which—

Figure 1 is a top view of the water-wheel embodying my invention. Fig. 2 is a central longitudinal section thereof. Fig. 3 is a side view of the chute of the wheel. Fig. 4 is a face view of the wheel and chute. Fig. 5 is a side view of the wheel.

Similar letters of reference indicate corresponding parts in the several figures.

My invention relates to a water-wheel, the motive power of which is adapted for sewing-machines and other purposes; and it consists of a cylindrical case, within which is mounted the wheel, adjacent to which are secured the distributing-chutes, the hub of which serves as a step for the wheel, the arrangement of the induction and eduction portions of the case being such that when the device is properly located the foot of the operator may readily open and close the cock or faucet of the water-supply. It also consists of a yoke, forming the bearings of the wheel-shaft, and guarding from displacement the band that passes around the pulley on said shaft.

Referring to the drawings, A represents a cylindrical case, which is provided intermediate of its ends with a projecting eduction branch, B, said case, when in position, occupying a horizontal position. One end of the case—at present the right-hand end—is the induction portion of the case; and within the case, at said end, there is secured the chute C, consisting of curved plates, the curvatures extending in the direction of the length of the case, and so shaped that the inner termination of each plate is at or about a point in line with the beginning of the adjacent plate.

D represents a shaft, which is passed into the case through a stuffing-box and packing, *b*, on the cap *a* of the case, and its inner end is mounted on the hub of the chute-plates C, said hub thus constituting the step of the shaft. On this shaft D there is keyed or otherwise secured a wheel, E, the buckets of which may be of any well-known form, and in the present case they consist of curved plates, the curvatures being in reverse order of the plates of the chute C, said wheel being located adjacent to the chute. The other end of the shaft D is mounted on a yoke, F, which is secured to the case A; and on the shaft, at a point between the yoke and the cap *a* of the case, there is secured a pulley or band-wheel, G.

The device, as described, will be located near the floor of an apartment, the case A occupying a horizontal position, and connected to a cock or faucet of the water-supply, the handle or lever of said cock or faucet thus occupying such position that the foot of the operator of a sewing-machine, or other apparatus requiring power, may conveniently reach said handle or lever, whereby the water is readily under control.

The water having been turned on, it enters the case A and reaches the chute C, whereby it is distributed to the buckets of the wheel E, which, as is evident, will be rotated, the power thereof being transmitted to the shaft D and pulley or wheel G; and, by means of a proper band, belt, or chain, said power will be communicated to the machine to be run. When the water leaves the wheel E it escapes through the branch B, after which it may be collected or directed elsewhere.

It will be noticed that I provide a simple, cheap, and sufficiently powerful motor for the purpose intended.

The wheel may be located accessible to the water-supply, and the latter, in relation thereto, conveniently regulated by foot. The chute serves to distribute the water, and provides the step for the wheel-shaft. The yoke forms the bearing for one end of the wheel-shaft, and sufficiently incloses the pulley or band-wheel thereof that the feet or dress of the op-

erator will be prevented from coming in contact with the pulley or the band passing around it, the advantages of which are evident.

Having thus described my invention, what I claim as new, and desire to secure by Letters Patent, is—

1. The case A, with cap *a* and projecting discharge branch B, in combination with the fixed chute C, wheel E, having its inner bearings on said chute as a step, and shaft D, substantially as and for the purpose set forth.

2. The case A, with branch B, and wheel-

shaft D, with pulley G, in combination with the encircling yoke F, substantially as and for the purpose set forth.

3. The case A, in combination with the chute C, fixed within the case, and the wheel E, having its inner bearings on said chute as a step, substantially as and for the purpose set forth.

ASA JOSEPH STOTT.

Witnesses:

THOS. H. CLARKE,
A. J. KRAUSE.