

F. C. WILSON.
CAN-TOP.

No. 188,222.

Patented March 6, 1877.

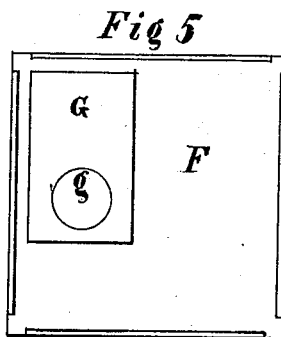
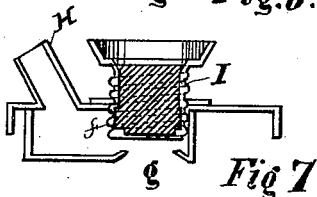
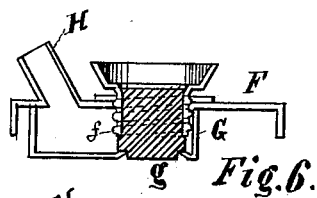
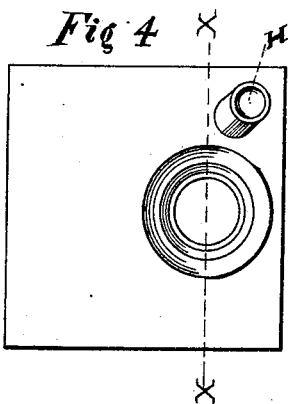
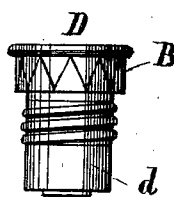
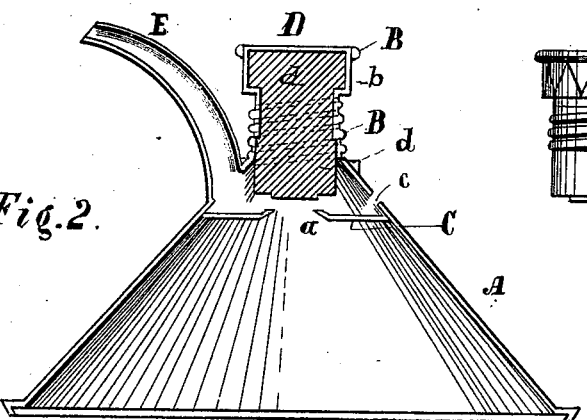
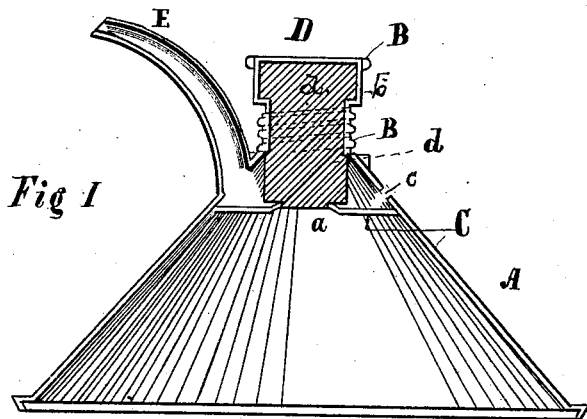

Attest;
W. C. Coates
C. S. Lloyd.

Fig. 8.

INVENTOR;
F. Cortez Wilson
Per. Columbus Thacker
Attys.

UNITED STATES PATENT OFFICE.

F. CORTEZ WILSON, OF CHICAGO, ILLINOIS.

IMPROVEMENT IN CAN-TOPS.

Specification forming part of Letters Patent No. 188,222, dated March 6, 1877; application filed December 11, 1876.

To all whom it may concern:

Be it known that I, F. CORTEZ WILSON, of Chicago, in the county of Cook and State of Illinois, have invented a new and useful Improvement in Can-Tops, which is fully set forth in the following specification, reference being had to the accompanying drawings, in which—

Figure 1 represents a cross-section of the top of a pitch-top can, with my invention applied, the stopper being turned down to entirely close the opening into the can; Fig. 2, the same, with the stopper raised slightly to permit the contents of the can to be turned out; Fig. 3, a view of the stopper; Fig. 4, a plan view of the top of a square can, with my invention applied; Fig. 5, the same, in an inverted position; Fig. 6, a cross-section taken on the line *x x*, Fig. 4, with the can closed; Fig. 7, the same opened, and Fig. 8 a view of the stopper.

The object of my invention is to construct the top of a can in such a manner that it may be emptied through the spout for that purpose, but without the necessity of entirely removing the stopper from the main opening, and, at the same time avoid the use of a nozzle made separately and attached to the can.

The invention consists in constructing the top of the can with a diaphragm inside of and extending entirely across the top proper, so as to make a small chamber just below the main opening into the can, which is somewhat larger in circumference than the can-stopper, and has an opening into the interior of the can just below the stopper, which can be closed by turning down the latter; and also in combining with the top thus constructed a spout opening directly into the chamber, through which the can may be emptied without entirely withdrawing the stopper.

In the drawings, A represents the breast of a pitch-top can, which is of ordinary construction in its general features, and is provided with ears on each side of the nozzle for the attachment of a bail. This top is finished at its apex with a nozzle, B, which is provided with an internal screw-thread, as shown in the drawings. Within the top of the can, and a little ways below this opening, a diaphragm, C, is placed, which is made with an opening,

a, just below the main opening, through which communication is established with the interior of the can. The opening *a* is a little smaller than the lower end of a stopper, D, so that when the latter is turned down it will fit upon and over the former, as shown in Fig. 1 of the drawings, thereby effectually closing all openings into the can. The stopper D is constructed with a large internal core, *d*, of cork, or any other suitable elastic material, which is provided with an exterior metallic covering, *b*, upon its upper end. The stopper is made of such size that it will fit the nozzle B, the metallic covering *b* being threaded, so that it may be screwed into the nozzle. The lower end of the stopper below the metal covering *b* is a little larger than the nozzle B, so that it will fit tightly in the latter whenever it is drawn up into it. A small stem or spout, E, is attached to the breast-top in such a position that it will open directly into the chamber or space at the upper end of the can-top between the diaphragm C and the nozzle B. The top being conical, it is evident that the chamber formed above the diaphragm C will be larger in circumference than the stopper D, which is inserted through the nozzle B. For this reason, whenever the stopper is turned up so as to be raised slightly from its seat on the diaphragm, as shown in Fig. 2 of the drawings, the contents of the can may be emptied therefrom, the fluid flowing through the opening *a* into the unoccupied space in the chamber above the diaphragm, and thence out through the spout. This operation is effected without removing the stopper from the can, and as the lower end of the stopper is a little larger than the nozzle B, it will fit tightly in the latter when drawn up into it, as described above, and thus prevent the escape of any fluid into and through the nozzle. There should be a small vent-hole, *c*, in the breast of the top opening into the chamber.

When it is desired to fill the can it is only necessary to entirely withdraw the stopper D by screwing it up through the nozzle B, and the can may then be filled through the latter and the opening in the diaphragm. When filled, the stopper is inserted and turned completely down upon the diaphragm, thus completely closing the can.

In applying my invention to a square-topped can the chamber below the main opening is obtained by fastening to the bottom of the top F a box-shaped piece, G, as shown in Figs. 5 and 6 of the drawings. This supplementary chamber is provided with an opening, *g*, into the interior of the can, located with reference to the main opening, as described above. A spout attached to the top of the can opens directly into the chamber for the same purpose as the spout E, described above. A flange, *f*, projects inward from the top F around the main opening, which is provided with an internal screw-thread, and extends down one-half or three-quarters of the way to the opening *g*, as shown in Figs. 6 and 7 of the drawings.

The stopper I is constructed generally like the stopper D, above described, and fits in the flange or depressed nozzle *f* in the same way as the stopper D in the nozzle B.

It is evident that the operation of these de-

vices applied, as above described, to a square-topped can, will be precisely the same as in the conical top heretofore described, and that the same results will be obtained.

Having thus described my invention, what I claim as new, and desire to secure by Letters Patent, is—

1. A can-top, provided with a perforated diaphragm, C, within and extending entirely across the top, substantially as and for the purpose set forth.

2. The breast A, terminating in a nozzle, B, at its apex, in combination with the diaphragm C, within and extending across the top, and provided with an orifice, *a*, the stopper D, and spout E, substantially as and for the purpose set forth.

F. CORTEZ WILSON.

Witnesses:

E. S. LLOYD,
L. M. HARRIS.