

R. TOBIN.

WIND ANCHORS FOR FRAME-HOUSES.

No. 188,442.

Patented March 13, 1877.

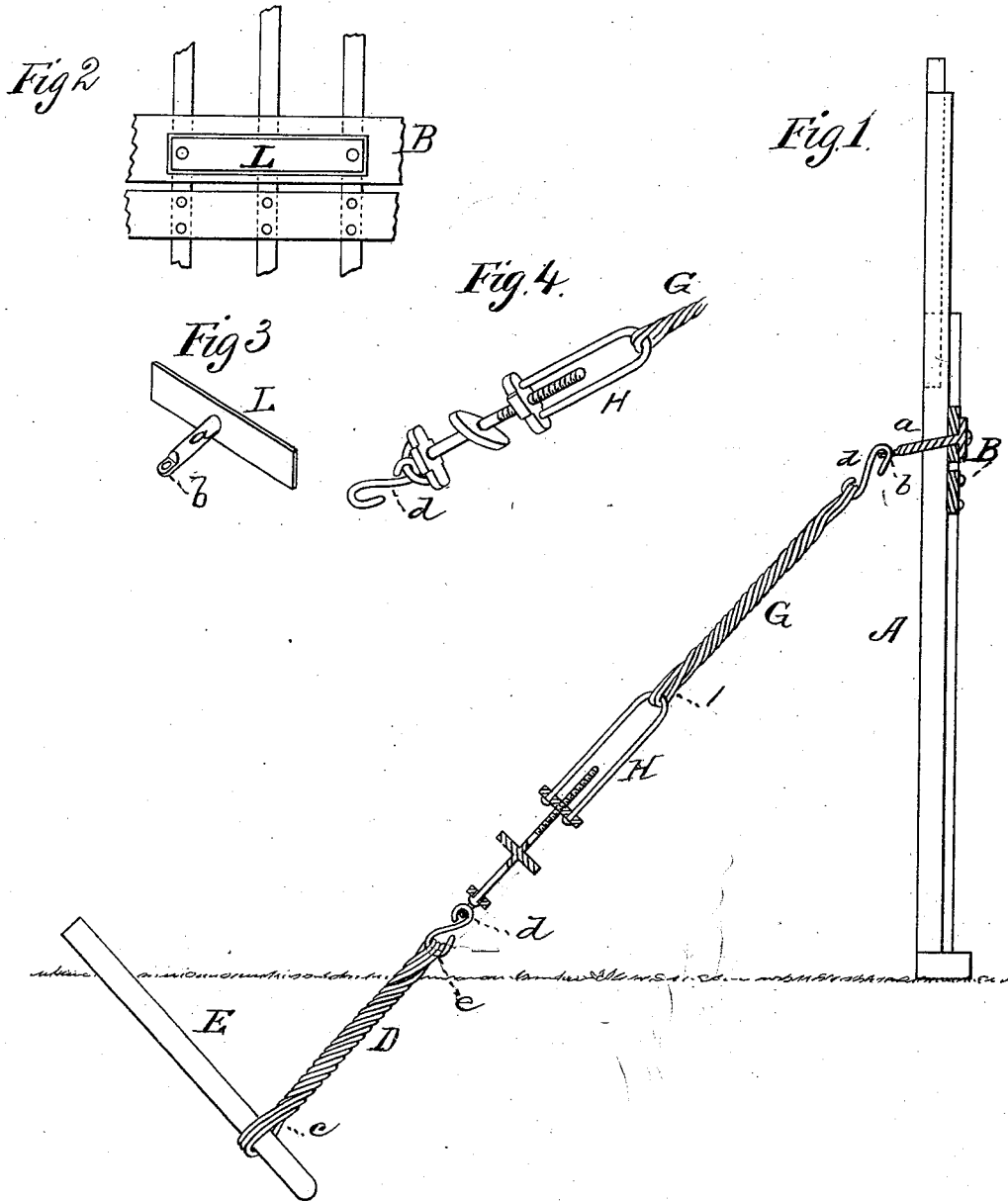

WITNESSES  
*Villett Anderson.*  
*A. J. Olasi*

INVENTOR  
*Richard Tobin,*  
*14 E. W. Anderson,*  
ATTORNEY

# UNITED STATES PATENT OFFICE.

RICHARD TOBIN, OF MACOMB, ILLINOIS.

## IMPROVEMENT IN WIND-ANCHORS FOR FRAME HOUSES.

Specification forming part of Letters Patent No. **188,442**, dated March 13, 1877; application filed February 10, 1877.

*To all whom it may concern:*

Be it known that I, RICHARD TOBIN, of Macomb, in the county of McDonough and State of Illinois, have invented a new and valuable Improvement in Wind-Anchors for Frame Houses; and I do hereby declare that the following is a full, clear, and exact description of the construction and operation of the same, reference being had to the annexed drawings, making a part of this specification, and to the letters and figures of reference marked thereon.

Figure 1 of the drawings is a representation of a sectional view, showing this invention in use. Fig. 3 is a perspective view of the fastening-plate. Fig. 2 is a rear or inside view, showing the position of the fastening-plate with reference to the finishing-board; and Fig. 4 is a perspective view of the buckle.

This invention has relation to means for preventing houses from being blown down by the wind; and it consists in the construction and novel arrangement of the fastening-plate for the house and the stake-anchor, and in combination therewith of the connecting rope or chain and turn-buckle, as hereinafter shown and described.

In the accompanying drawings, the letter A designates the end of a frame house, a story and a half high, without siding. B represents the finishing-board on the inside above the floor-beams of the upper story. G designates my house-fastening plate. This consists of an oblong bar or plate, which is designed to fit against the inside face of the finishing-board, and is provided with an oblique arm or projection, *a*, which extends through the board C and the siding, and is provided with an eye, *b*, at its outer end. This arm *a* is directed obliquely downward toward the ground. D represents a wire rope or connection having a loop at each end. This rope is designed

to be connected by its lower loop *c* with a stake or anchor-bar, E, which is buried in the ground in an oblique position inclining from the house. The connection is made by passing the lower end of the stake through the loop *c*, as indicated in the drawings. G indicates the rope, chain, or other connection, extending from the loop *d* of the anchor to the eye *b* of the arm of the fastening-plate. This is designed to be provided with hooks *d* for ready attachment, and with a turn-buckle, H, in order that it may be drawn taut when attached. This rope or chain G is not designed to be always in connection between the house and anchor. It is easily detachable, and may be put away in some convenient place until the necessity arises for its use. Without the connection G the appearance of the house would present nothing unusual. The surface loop *e* of the anchor-rope or stem D would be about even with the surface of the ground, and the arm *a* would just project beyond the siding of the house.

It is designed to employ this form of anchor in staking windmills, land capstans, wire fences, and other structures liable to strain.

Having described my invention, what I claim as new, and desire to secure by Letters Patent, is—

The combination, with the inside house-plate having the oblique-projecting arm *a*, of the buried anchor-stake E, its looped rope or stem D, and the connection G, substantially as specified.

In testimony that I claim the above I have hereunto subscribed my name in the presence of two witnesses.

RICHARD TOBIN.

Witnesses:

JOHN MOSHER,  
WILLIAM E. ODELL.