

J. H. FISHER.

BALE-TIES.

No. 188,506.

Patented March 20, 1877.

Fig. 1.

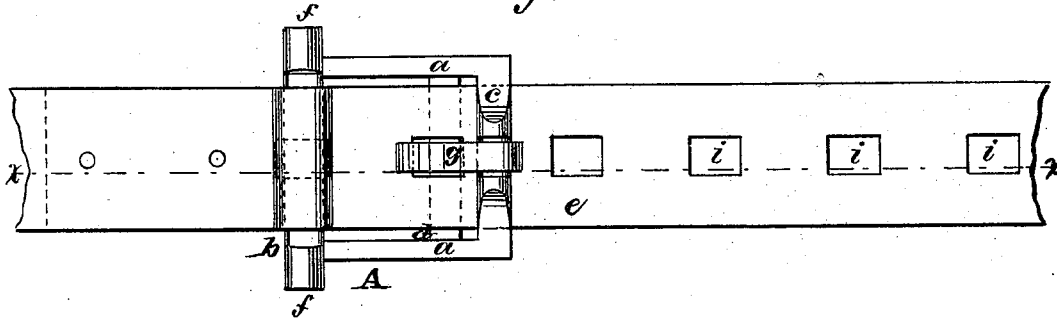
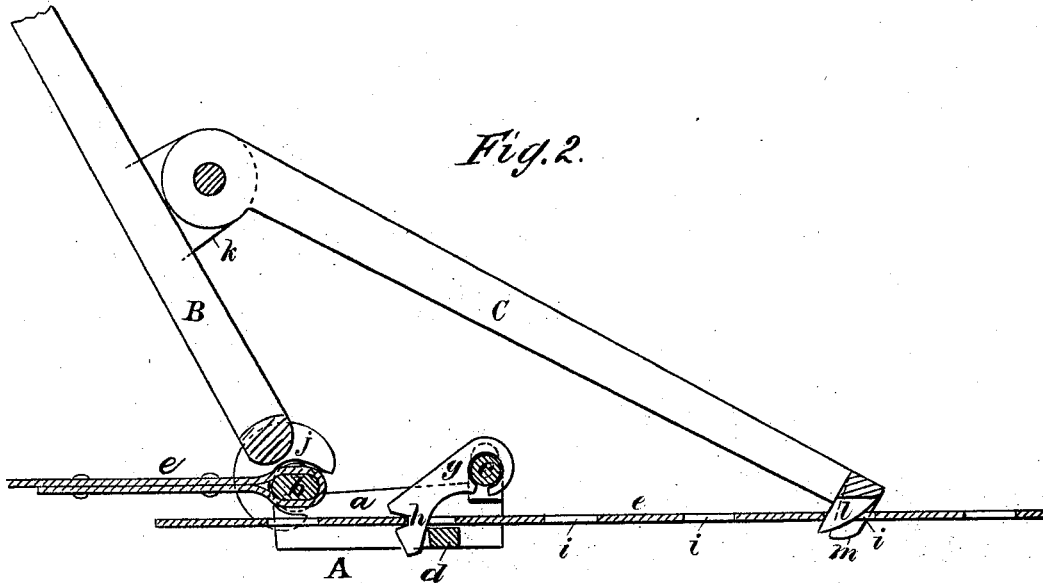

Fig. 2.



WITNESSES:

E. Wolff.
J. H. Scarborough.

INVENTOR:

J. H. Fisher.
BY *Munnell*

ATTORNEYS.

UNITED STATES PATENT OFFICE.

JOSEPH H. FISHER, OF CHICAGO, ILLINOIS.

IMPROVEMENT IN BALE-TIES.

Specification forming part of Letters Patent No. **188,506**, dated March 20, 1877; application filed January 29, 1877.

To all whom it may concern:

Be it known that I, J. HYDE FISHER, of Chicago, in the county of Cook and State of Illinois, have invented a new and Improved Bale-Band Buckle and Tightener, of which the following is a specification:

Figure 1 is a side view of my improved buckle. Fig. 2 is a longitudinal section on line *x x*, Fig. 1, showing the tightener in connection with the buckle.

Similar letters of reference indicate corresponding parts.

My invention consists in a buckle of peculiar construction, adapted to a metallic strap or band to which it is attached, and in a lever for engaging horns or projections on the sides of the said buckle, and a hooked pawl for engaging holes in the bale-band.

Referring to the drawing, A is a buckle, which consists of the parallel side pieces *a a* and the transverse bars *b*, *c*, and *d*, which connect the said side pieces. The bars *b* and *c* are attached to the upper edges of the side pieces, and the bar *d* to the lower edges. The end of the bale-band *e* is looped around the bar *b* and riveted, and the said bar is provided with projecting ends *f* that extend beyond the side pieces *a a* for receiving the end of the lever, by means of which the band is tightened. The buckle-tongue *g* is placed upon the bar *c*, and rests when in its normal position against the bar *d*. A notch, *h*, is formed in the end of the tongue *g* for receiving the edge of the band *e* at the end of the holes *i*. The band *e* passes over the bar *d*

and under the bars *b c* through the buckle in a straight line. B is a lever that is forked and provided with the clutches *j j* that engage the projecting ends *f* of the bar *b*. C is a pawl that is pivoted between ears *k* projecting from the lever B, and is provided with a hook or nib, *l*, and with guides *m m* that engage the sides of the band *e*, so that the nib *l* engages the holes *i* in the center of the band. The buckle is capable of being used without the tightener by simply moving the perforated end of the band through it, and allowing the tongue to drop into the perforation; but if it is desired to draw the band still tighter, the lever B is placed on the projections *f*, and the nib *l* is made to engage one of the holes *i* when the band is drawn through the buckle by moving the lever B. The tongue *g* drops into one of the holes *i* and retains the band. The lever B may also be used for unfastening the bands when the bales are to be opened.

Having thus described my invention, I claim as new and desire to secure by Letters Patent—

A bale-band buckle, having top bars *b c* connecting side bars *a a*, a bottom bar, *d*, and a notched tongue, *g h*, the latter pivoted to bar *c*, and when under strain resting against the bar *d*, as shown, and for the purpose specified.

JOSEPH HYDE FISHER.

Witnesses:

WM. S. MCKNIGHT,

CHS. W. SPEER.