

J. LONG, Jr.

SHUTTLE-BOX MOTIONS FOR POWER-LOOMS.

No. 188,523.

Patented March 20, 1877.

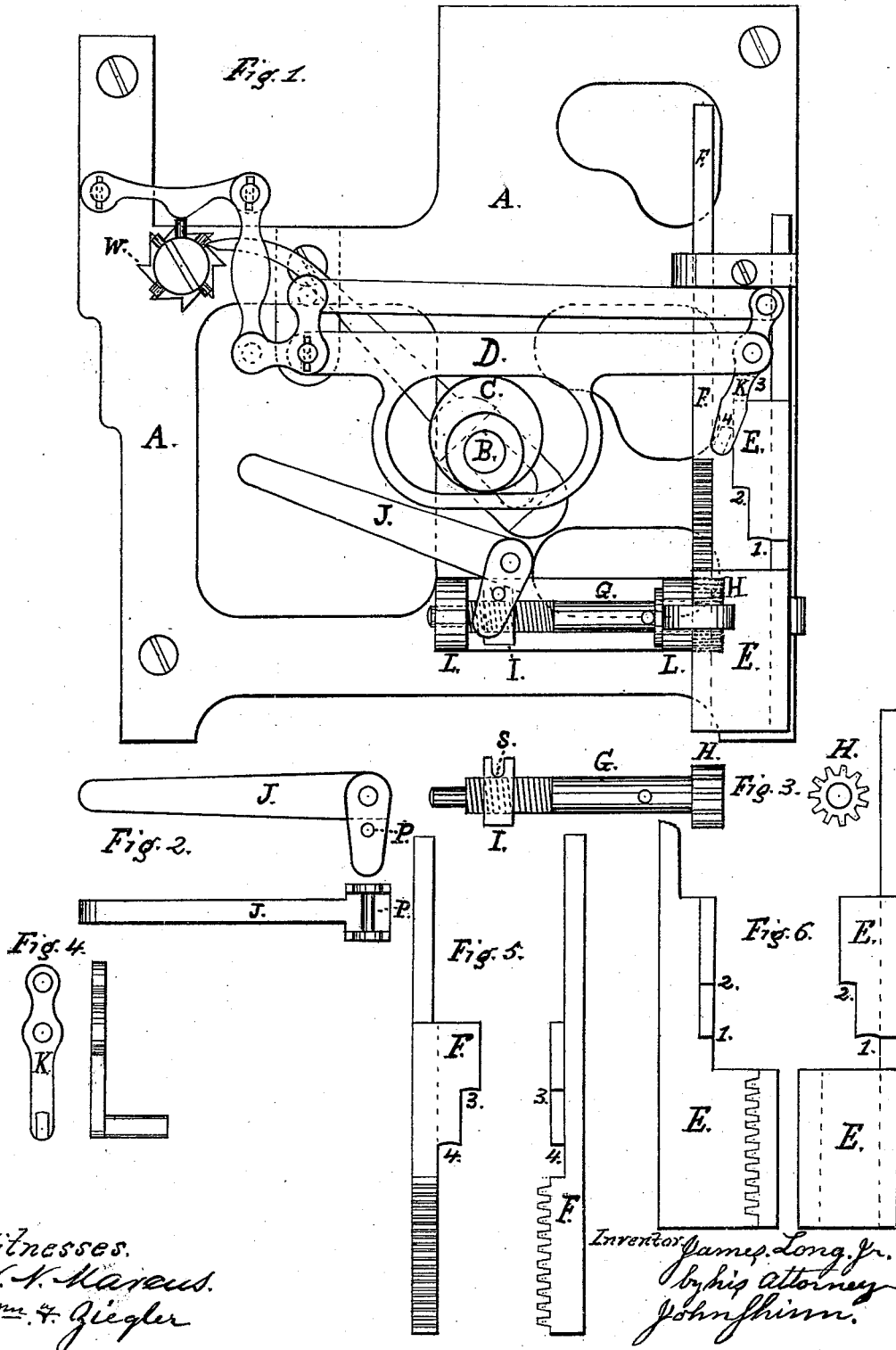

Witnesses.
H. K. Marcus.
Wm. F. Giegler

Inventor James Long, Jr.
By his Attorney
John Himm.

UNITED STATES PATENT OFFICE.

JAMES LONG, JR., OF PHILADELPHIA, PENNSYLVANIA, ASSIGNOR TO JAMES LONG, SR., OF SAME PLACE.

IMPROVEMENT IN SHUTTLE-BOX MOTIONS FOR POWER-LOOMS.

Specification forming part of Letters Patent No. **188,523**, dated March 20, 1877; application filed January 17, 1877.

To all whom it may concern:

Be it known that I, JAMES LONG, Jr., of the city of Philadelphia, and State of Pennsylvania, have invented a new and useful Improvement in Shuttle-Box Motions for Power-Looms, which improvement is fully set forth in the following specification and accompanying drawings, in which—

Figure 1 is an end view of a loom-frame, showing my improvement. Fig. 2 is a view of the lever J. Fig. 3 is a view of shaft G, nut I, and pinion-wheel H. Fig. 4 is a view of the lifter K. Fig. 5 is a view of vertical sliding rack F. Fig. 6 is a view of vertical sliding rack E.

Similar letters in the drawings refer to like parts.

The object of my invention is to construct a simple, compact, and efficient drop-box mechanism for power-loom, the operation of which shall be positive, and capable of attaining a high speed; and the invention consists in the combination of two sliding racks, operating a pinion-wheel fixed on and to a shaft, upon which is cut a screw-thread carrying a nut connected to the heel of a lever on the side of the loom, and to which is usually connected the lifting-rod of the shuttle-boxes, the pattern to be woven and changes of boxes being controlled by movable pins of different lengths in a wheel or chain, operating at the side of the loom, in the usual and well known manner.

A represents the frame of the loom; B, the bottom or cam shaft; C, the eccentric cam for operating the lever D, in the right-hand end of which is hung on a pin the lifter K. E and F are the sliding racks, and are constructed with spur-teeth on the lower ends, and are each provided with shouldered projections 1, 2, 3, and 4, two on each rack. This number is required to operate three boxes. To operate four boxes three projections are required on each rack, and a greater length and number of teeth on each rack. G is a shaft set in a frame, L, fixed to the loom-side. On this shaft is fixed pinion-wheel H, and on the opposite end is cut a screw-thread, upon which is fitted a nut, I, in the top of which is cut a slot, S, into which fits a pin, P, fixed in the heel of the lever J. To the left-hand end of

lever J is connected the lifting-rod, supporting the shuttle-boxes in the usual manner.

In Fig. 1 is shown a ratchet-wheel, W, in which are five pins, one being longer than the others. The pin-wheel is operated in the usual manner by a pawl moved by a cam on the shaft B, and the action of the pins is conveyed to the lifter K by the connections, as shown in Fig. 1.

As before stated, the movements of the boxes are controlled by movable pins of different lengths. A long pin will call the bottom box, a short one the middle box, and a blank space or empty hole the top box. This being understood, I will describe the operation, which is as follows: Motion is communicated to the shaft B in the usual manner, and the eccentric cam C gives a lifting movement to the lever D, and this, in turn, to lifter K. In Fig. 1 is shown the long pin in action, and the lifter K engaged in notch 4, on rack F, and the bottom shuttle-box is elevated for operating the shuttle belonging to that box. The next move of the pin-wheel will present a short pin, and the lifter K will engage in notch 2 on rack E. This will raise rack E, and, since this is geared into the pinion H, it will revolve the latter, and the rack F, being geared on the opposite side of pinion H, will be drawn down when E rises, and in the same manner will E be drawn down when F rises. The raising of rack F, as before described, revolves the screw or shaft G, and screws the nut I to the right, depresses the end of lever J, which, in turn, will put the middle shuttle-box in position for operating that shuttle. The next move of the wheel will present a blank or an empty hole in the pin-wheel, and the lifter K will engage in the notch 1 on rack E, raising it still higher, and the rack, moving pinion-wheel H, will move the nut I still farther to the right, and, as before, operating through the lever J the shuttle-boxes, will drop them into position for the shuttle to be operated from the top box. At the next move of the pin-wheel a short pin will act. This will cause the lifter K to engage in the notch 3 on rack F, raising it, and it, in turn, being geared into pinion H, will revolve screw G, moving the nut I to the left. This will raise the shuttle-

boxes to operate the shuttle from the middle box. The next move of the pin-wheel will present a blank. This will place top box in position, as before described. The next move of pin-wheel will present a short pin, and the middle shuttle-box will be again in position for that shuttle; the next move, a blank, and the top box will be called again; the next move a short pin, calling the middle box; the next move a long pin, when the lifter K will engage the notch 4 on rack F, and this will lift the shuttle-boxes to operate the shuttle from the bottom shuttle-box, and the operating parts will be in position as shown in Fig. 1 of the drawings.

It will be understood that the design or pat-

tern of colors to be woven is controlled by the position of the short and long pins in the ratchet-wheel W. In practice I prefer to use a chain.

I claim—

The combination, with the racks E and F, mechanism for operating the same, and shaft G, provided at one end with the pinion H, and at the other end with a screw-thread, of the nut I and box-lever J, as and for the purpose specified.

JAMES LONG, JR.

Witnesses:

WM. N. MARCUS,
JOHN SHINN.