

W. HIPPERLING.
SEAMING-MACHINE.

No. 188,633

Patented March 20, 1877.

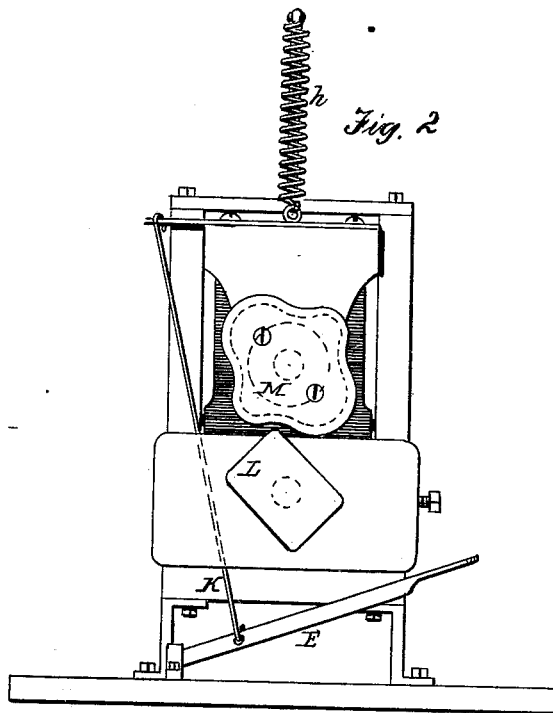
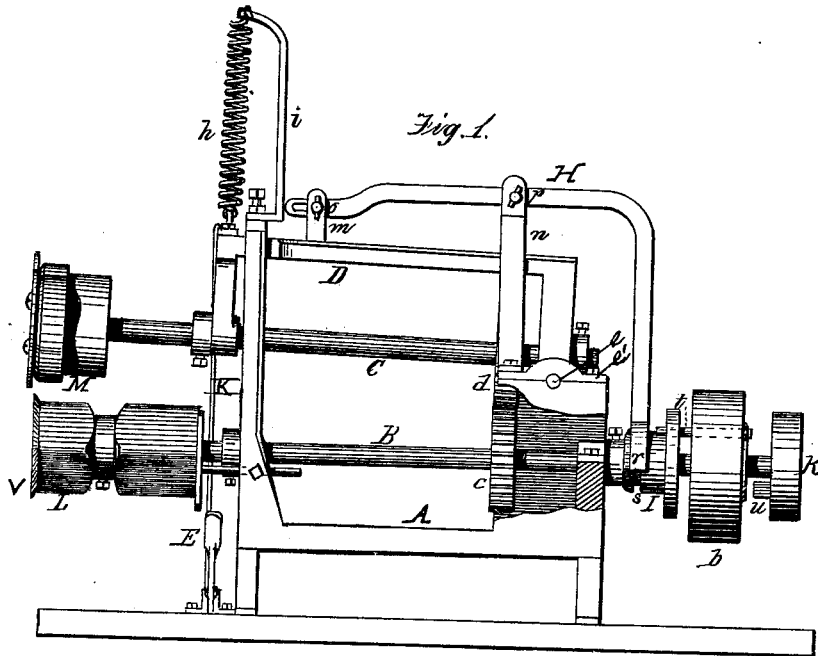

Witnesses;
Grenville Lewis
Chas. O'Bill

Inventor
Wm. Hipperling
by his attys.
Cox & Cox.

UNITED STATES PATENT OFFICE.

WILLIAM HIPPERLING, OF NEW YORK, ASSIGNOR TO S. L. HINES AND RICHARD A. DONALDSON, OF BROOKLYN, N. Y., AND STEPHEN A. GINNA, OF PLAINFIELD, N. J.

IMPROVEMENT IN SEAMING-MACHINES.

Specification forming part of Letters Patent No. 188,633, dated March 20, 1877; application filed January 24, 1877.

To all whom it may concern:

Be it known that I, WILLIAM HIPPERLING, of New York, in the county of New York and State of New York, have invented a new and useful Improvement in Machines for Crimping Sheet Metal, of which the following is a specification, reference being had to the accompanying drawings.

The invention relates to machines for crimping the edges of sheet-metal cans or receptacles.

Great difficulty and inconvenience have heretofore been experienced in attaching the bottoms to cans or other sheet-metal vessels of an angular or relatively angular configuration. To obviate this difficulty and inconvenience is the object of the invention, which is effected by constructing the crimping-head of a peculiar and novel shape, so that its periphery adapts itself to crimp the metal upon an angular former-head without jar or irregular action, and in providing a clutch of any construction, whereby a ready means of removing the can or vessel after the bottom has been attached is secured. The exact nature of the invention is hereinafter fully set forth, from which and the drawings its object will more fully appear.

In the drawings, Figure 1 is a side elevation, partly in section. Fig. 2 is an end elevation, showing, particularly, the construction of the heads L and M.

In the accompanying drawings, A denotes the frame of the machine, which is of usual construction. B is the axle or shaft of the former-head, and C the axle or shaft of the crimping-head. The shaft B is provided with the belt-wheel *b* and the cog-wheel *c*, which meshes with the cog-wheel *d* upon the shaft C. D is an interior frame adapted to support the shaft C and other parts. The frame D is provided with bearings *e*, that are secured in boxes *e'* upon the main frame A, and is sustained so as to hold the crimping-head free of the former-head by means of the spring *h*, the upper end of which is attached to the vertical support *i*, that is secured to the frame A. The frame D, with the crimping-head, is

depressed at will by means of the treadle E, which is connected with the frame D by the rod *k*, and adapted to conveniently effect its offices in any appropriate manner. These elements and parts are not new, and their construction and operation are so well understood that a more exact description of them need not be presented. The invention is embodied in the features hereinafter specified.

To the upper section of the frame D are secured the brackets or supports *m*, and in line therewith the supports *n*, the latter being attached to the frame A. These brackets or supports serve to sustain the bent lever H, to effect which object the pins *o p* are provided, a horizontal slot being cut in the end of the lever to accommodate the former, and an aperture to receive the latter. The depending end of the lever H is in the form of a yoke, at the ends of which are studs or warts *r*, which rest in the groove *s* in the dead-wheel I, which turns or may be moved laterally upon the shaft B. To the wheel I is rigidly secured the bolt or bayonet *t*, which is carried through a hole in the belt-wheel *b*, and is of such length that when the lever H is actuated its free extremity will obstruct the revolution of the projection *u* upon the wheel K, which is rigidly attached to the shaft or axle B, whereby the shaft or axle B and all its adjuncts are caused to revolve simultaneously. By this construction I provide a convenient form of clutch, whereby it is practicable to check the rotation of the former-head at will—a circumstance of very great consequence, by reason of the fact that if the former-head is angular it is scarcely possible to remove the object upon it while it is in motion, as may be done without difficulty if the former is round.

To the outer end of the shaft or axle B is secured, in the customary manner, the former-head L, which, in the present instance, is substantially in the shape of a parallelogram, but which may be of any angular configuration in which sheet-metal vessels are fabricated. Contiguous to it is the shield *v*, and it is constructed with the customary lip or raised rim,

so as to effect the crimping of the edge of the sides of the can upon the bottom, or the edge of the bottom upon the sides, at will, as may be preferred; but the head L differs from other heads only in that it is angular in shape.

To the outer end of the shaft or axle C is secured, in the customary manner, the crimping-head M, its axial center being in the same longitudinal vertical plane as the axial center of the head L, the parts hereinbefore mentioned being arranged and disposed accordingly. In the present instance the head M is constructed with relation to the shape of the particular former-head shown and described, being intended for use in the fabrication of cans or vessels of the shape of a parallelogram; but it may be adapted to cans or vessels of other angular shapes, as may be desired.

The distinctive novelty of the crimping-head M consists in the fact that its periphery is provided with concavities or gradual depressions, which travel around the angles of the former-head, the concavities coinciding, to all intents and purposes, in length of outline with the length of outline of the angle to be crimped less the space occupied by the metal. It is not essential that the proportions be exact, it being only necessary that allowance be made for the metal, the periphery of the crimping-head being nearly or about equal to the periphery of the former-head, and the concavities made to move upon the angles, so as to preserve an evenness of pressure as near as may be practicable. The nearer the approximation to the exact relations stated the better will be the result; but a satisfactory result will be attained even if the embodiment of the invention is somewhat removed from that particularly recommended. The effect of this construction is, that the crimping of angular cans or vessels is done with great ease and without jar as satisfactorily as in the case of those that are round.

It is apparent that the shape of the crimping-head M may be adapted to use, as hereinbefore stated, in the fabrication of cans or vessels of any angular shape in which sheet-metal receptacles are constructed.

The operation of the machine will be readily understood from the foregoing description of its parts. Power having been applied, the belt-wheel *b* moves free. The can is placed upon the former-head L, and the treadle carried down. Thus the heads L and M are held together by means of the clutch, and these devices being rotated the process of crimping is speedily effected. The treadle is then allowed to rise, being elevated by the upward motion of the frame D, caused by the spring *h*, thus permitting the belt-wheel *b* to move free. The can is then taken from the former-head, and the operation aforesaid repeated.

What I claim as new and useful, and desire to secure by Letters Patent, is—

1. The crimping-head M, having four concavities or depressions in its periphery, substantially as shown and described, and for the purpose specified.

2. The combination of the head M, having four concavities in its periphery, with the head L, having four angles upon its periphery, substantially as and for the purpose set forth.

3. A crimping-head the periphery of which is elongated by concavities or depressions, for the purpose set forth.

4. The combination of an angular former-head with a crimping-head having concavities or depressions, substantially as set forth.

In testimony that I claim the foregoing improvement in machines for crimping sheet metal, as above described, I have hereunto set my hand this 19th day of January, 1877.

WILLIAM HIPPERLING.

Witnesses:

C. H. DUELL,
JOHN GARDNER.