

J. McA. JONES.

SPRING HINGES.

No. 188,642.

Patented March 20, 1877.

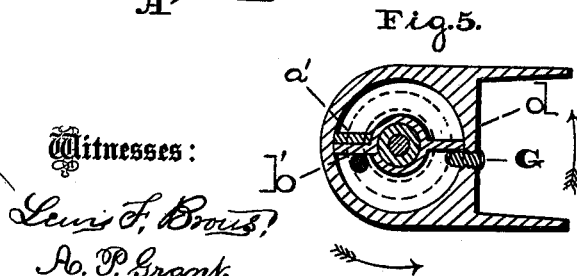
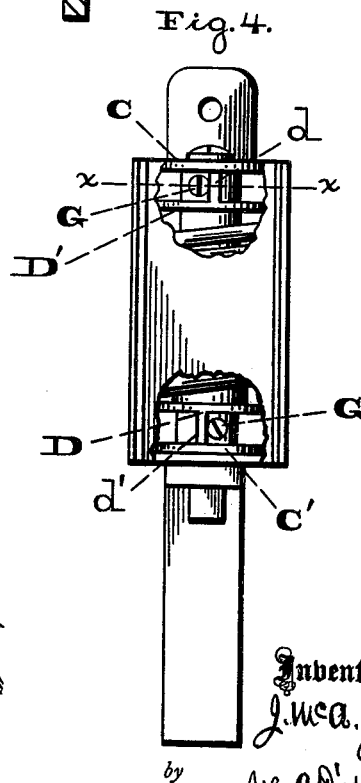
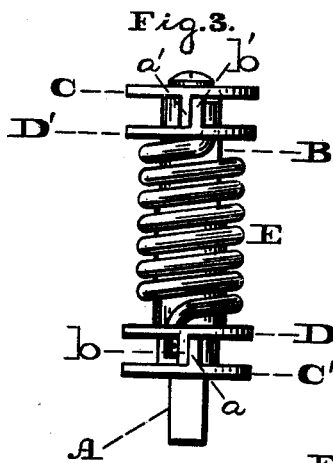
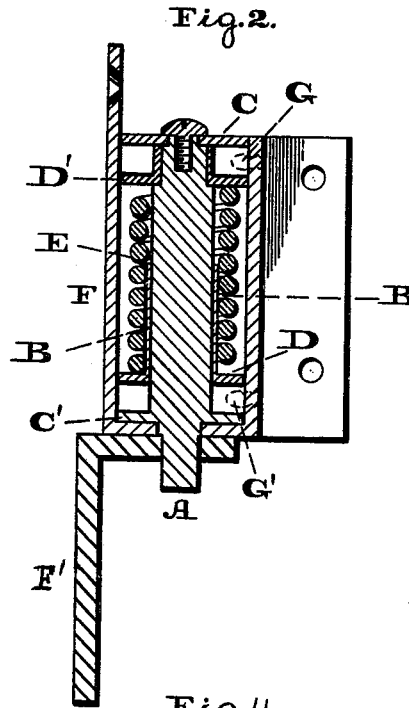
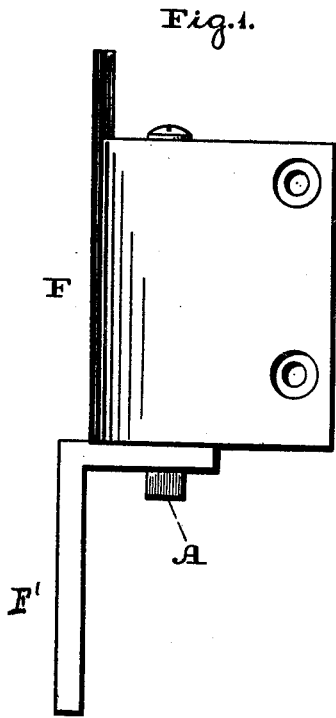

Witnesses:

Lewis F. Brown,
A. P. Grant.

Inventor:

J. McA. Jones.

by
Johann Fiedersheim
Attorney.

UNITED STATES PATENT OFFICE.

JOHN MCA. JONES, OF PHILADELPHIA, PENNSYLVANIA, ASSIGNOR OF
ONE-HALF HIS RIGHT TO WM. ALLEN, OF SAME PLACE.

IMPROVEMENT IN SPRING-HINGES.

Specification forming part of Letters Patent No. 188,642, dated March 20, 1877; application filed
February 26, 1877.

To all whom it may concern:

Be it known that I, JOHN MCA. JONES, of the city and county of Philadelphia and State of Pennsylvania, have invented a new and useful Improvement in Spring-Hinges, which improvement is fully set forth in the following specification and accompanying drawings, in which—

Figure 1 is a side elevation of the hinge embodying my invention. Fig. 2 is a central vertical section thereof. Fig. 3 is a side elevation of a detached portion. Fig. 4 is a side view, partly broken away. Fig. 5 is a horizontal section in line *x x*, Fig. 4.

Similar letters of reference indicate corresponding parts in the several figures.

My invention consists of a spindle and encircling spring, in combination with loose rings and lugs, so arranged with the spindle and inclosing box with holding pins or screws that the hinge is adapted for right or left hand purposes, as is required or necessary, as will be hereinafter more fully described and definitely claimed.

Referring to the drawings, A represents a spindle, on which is fitted a sleeve, B, and having secured to or formed with it, at opposite points, disks C C', with lugs *a a'*, projecting longitudinally toward each other. On the spindle adjacent to the disk C' is fitted a loose ring, D, and on the spindle, adjacent to the disk C, is fitted a loose ring, D', the two rings D D' being within the disks C C', and having secured to them the ends of a spring, E, coiled loosely around the spindle A. On the ring D is a lug, *b*, which engages with the lug *a* of the disk C', and on the ring D' is a lug, *b'*, which engages with the lug *a'* of the disk C. On the rings are also lugs *d d'*, which project in opposite directions, and toward the disks C C', respectively, as more readily seen in Fig. 4.

The parts as thus constructed and combined are fitted loosely but snugly in a box, F, which is adapted to be secured to the door in any well-known manner, one end of the spindle projecting from the box, and formed to engage with a bearing, F', which is attached to the door frame or jamb.

In order to properly connect the spindle, spring, and other parts, as described, to the box F, whose inner wall is cylindrical, there is passed through what may be termed the

“inner” part of the box two pins or screws, G G', of which the screw G bears against one side of the lug *d*, and the screw G' bears against the opposite side of the lug *d'*. Suppose the door is opened in the direction of the arrow, Fig. 5; in this case the spindle A remains stationary, the box F moves with the door, and the upper pin G is pressed against the lug *d*, which rotates the ring D', whereby the upper portion of the spring E will be compressed or contracted, the lower end of the spring being held from rotation by the contact of the lug *b* of the ring D against the lug *a* of the fixed disk C', and the lower pin G' moving with the box freely in the space between the ring D and disk C'. When the door is let go the expansion of the spring automatically closes it, the parts returning to their normal position. When, however, the door is opened in the direction the reverse of the arrow, Fig. 5, the spindle remains stationary, the box moves with the door, and the lower pin G' is pressed against the lug *d'*, which rotates the ring D, whereby the lower portion of the spring E will be compressed or contracted, the upper end of the spring being held from rotation by the contact of the lug *b'* of the ring D' against the lug *a'* of the fixed disk C, and the upper pin G moving with the box freely in the space between the ring D' and disk C.

It will thus be seen that, by means of the alternate engagement of the screws G G' with the respective lugs, the right and left automatic action of the hinge is available at all times, only a single spring is employed, and the hinge is powerful, simple in construction, and reliable in execution.

The sleeve B may be dispensed with, but it may be employed for preventing friction between the spring E and spindle A.

Having thus described my invention, what I claim as new, and desire to secure by Letters Patent, is—

The stationary spindle A and encircling-spring E, in combination with loose rings D D', lugs *a a' b b' d d'*, and an inclosing-box, F, with alternate-acting pins G G', substantially as set forth.

JOHN MCA. JONES.

Witnesses:

JOHN A. WEIDERSHEIM,
H. E. HINDMARSH